



Mascoutah
ILLINOIS

Project

Specifications

December 2020

**Sanitary Sewer Rehabilitation Project
Phase I**

Prepared for the
**City of Mascoutah
Illinois**

Prepared by

RJN Group, Inc.
St. Louis, MO
Professional Design Firm #184-000813



Mascoutah
ILLINOIS

RJN Group, Inc.
Project 15-3519-00

City of Mascoutah, Illinois
Sanitary Sewer Rehabilitation Project
Phase I
December 2020

A handwritten signature in blue ink, reading "Burcin Akkaya", is enclosed in a thin black rectangular border. The signature is written in a cursive style.

Burcin K. Akkaya, P.E.
Illinois P.E# 062-071408



INVITATION TO BID

Project Name: SANITARY SEWER REHABILITATION – PHASE I

Owner: City of Mascoutah, Illinois

Date: December 14, 2020

DESCRIPTION OF WORK

The City of Mascoutah is seeking contractors to undertake rehabilitation activities as specified within this Request for Proposal document. Details of the work are within the attached documents.

BID INFORMATION

Sealed bids will be received by the City of Mascoutah, Illinois (the Owner) until 10:00 a.m., local time, January 12, 2021. Bids received after this time will not be accepted. Bids will be opened and publicly read aloud immediately after specified closing time. All interested parties are invited to attend. Bids will be received at the following location:

City of Mascoutah
Office of the City Clerk
#3 West Main Street
Mascoutah, Illinois 62258

Bid Documents may be examined electronically at following web sites:

www.dodgeprojects.construction.com , www.siba-agc.org, www.mascoutah.org,

There will not be a pre-bid conference.

Bids will be received on a unit rate basis as indicated on the bid form.



Bidders shall be qualified to do business and licensed in accordance with all applicable laws of the state and local governments and local city ordinances where the Project is located.

Bids received from Bidders who are not recorded by Engineer as having received the Bid Documents will not be opened.

Prequalification of Bidders will not be required. Owner will evaluate Bidders in accordance with the Instructions to Bidders.

Bid security in the form of a certified or bank cashier's check or a Bid Bond in an amount not less than 5% of estimated value of contract shall accompany each Bid in accordance with the Instructions to Bidders.

Bids shall be in accordance with the Bid Documents.

COMPLETION

Completion time shall be as follows:

The Contract will be presented to Council for approval is January 19, 2021 and notice of award will be issued following Council approval. Notice to Proceed will be issued as soon as the selected contractor can file all forms with the City as described in the bid documents. The Work shall be completed within 90 calendar days from the Notice to Proceed.

ADDITIONAL PROVISIONS

The Bid shall be conditioned upon compliance with all applicable labor related requirements including the regulations and stipulations concerning equal employment opportunity, minority manpower utilization, affirmative action requirements, and minimum wage rates. Illinois Department of Labor Prevailing Wage Rate shall establish the minimum wages to be paid to workers under this Contract.



Mascoutah
ILLINOIS

OWNER'S RIGHT TO REJECT

The Owner reserves the right to reject any or all Bids and to waive irregularities therein, and all Bidders shall agree that such rejection shall be without liability on the part of the Owner for any damage or claim brought by any Bidder because of such rejections, nor shall the Bidders seek any recourse of any kind against the Owner because of such rejections. The filing of any Bid in response to this invitation shall constitute an agreement of the Bidder to these conditions.

OWNER

City of Mascoutah

Melissa Schanz

City Clerk

CONTRACT DOCUMENTS

**SANITARY SEWER REHABILITATION
PHASE I**

CITY OF MASCOUTAH

Illinois

DECEMBER 2020

**CONTRACT DOCUMENTS
FOR THE
SANITARY SEWER REHABILITATION
PHASE I**

TABLE OF CONTENTS

TITLE	Pages
PROJECT SPECIFICATIONS	
REQUEST FOR PROPOSALS	RFP1- RFP4
# BID BOND	BB1 - BB2
# BID FORM	BF1 – BF9
# SUBCONTRACTORS	Page 1
AGREEMENT	Page 1-9
PERFORMANCE BOND	Page 1-3
PAMENT BOND	Page 1-3
SECTION 00700 - GENERAL CONDITIONS	00700-1 – 00700-48
 SPECIFICATIONS	
Division 1 Table of Contents	D1-1-1 – D1-11-2
*Specifications	
Division 2 Table of Contents	D2-1-1– D2-24-8
*Specifications	
Special Provisions	SP-1-1 – SP-5-2
 DRAWINGS, EXHIBITS and REPORTS	
Construction Plans for Replacement of Segment MH174:MH133	
Typical Details	
Rehabilitation Schedules & Exhibits	
Overall Sewer Rehabilitation Map	
Open-cut Point Repair Schedule & Maps	
CIPP Lining Schedule & Maps	
CIPP Point Repair Schedule & Maps	
Geotechnical Interpretive Report for Sanitary Sewer Line Replacement	

* Section has individual Table of Contents.

Items to be included in bid package.

City of Mascoutah, Illinois
Sanitary Sewer Rehabilitation Phase I

REQUEST FOR PROPOSALS

PART 1 GENERAL INFORMATION:

ARTICLE 1 -

- A. The City of Mascoutah is seeking proposals for the rehabilitation of sanitary sewer segments in various parts of the City.

ARTICLE 2 -

- B. All proposals must be received by 10:00 A.M. CST by the City of Mascoutah clock on January 12, 2021. Proposals received after that date and time will not be considered. Interested parties must submit their proposal on the forms provided in this proposal request to:

City of Mascoutah
3 West Main Street
Mascoutah, IL 62258

ARTICLE 3 -

- C. All correspondence concerning this RFP should be addressed to:

Burcin Akkaya - RJN Group, Inc.
2000 South 8th Street
St Louis, MO 63104
Phone 314-250-5127 or e-mail: bakkaya@rjnmail.com

- D. SUBMITTALS must be provided on the forms provided in this RFP and other information as requested below. The Firm shall provide a project description, work schedule, list of all similar projects completed in the last five years, company profile, personnel to be assigned to the project and references.
- E. EXAMINATION OF PLANS, SPECIFICATIONS AND SITES: Bidders shall inform themselves thoroughly as to all the difficulties that may be encountered in the complete execution of all the work under the attached contract.

Upon request, all available information in the possession of the City will be shown to bidders, but correctness of any such information is not guaranteed by the City.

No pleas of ignorance of conditions that exist, or of conditions or difficulties that may be encountered in the execution of the work under this contract, as a result of failure to make the necessary examinations and investigations will be accepted as an excuse for any failure or omission on the part of the Contractor to fulfill in every detail all the requirements of said contract, specifications and drawings, or will be accepted as a basis for any claim whatsoever for additional compensation.

- F. **DELIVERY OF PROPOSALS:** Proposals shall be delivered prior to the time and at the place indicated in Part 1. Article 2. Each proposal shall be placed in a sealed envelope plainly marked to indicate its contents. Only sealed proposals will be accepted.
- G. **CONTRACT BOND:** The successful bidder shall execute a performance bond for the faithful performance of such contract in the sum of the total amount of the contract with a surety company whose financial standing is satisfactory to the City. The bond will continue in force until such time as final acceptance is made in writing by the City.
- H. **INSURANCE:** The Contractor shall secure and maintain such insurance from an insurance company authorized to write casualty insurance in the State of Illinois as will protect himself, his subcontractors, the City, including duly authorized representatives, from claims for bodily injury, death or property damage which may arise from operations under this Contract. The policy shall name the City and RJN Group, Inc. as an additional insured. The Contractor shall not commence work under this Contract until he has obtained all insurance required under this paragraph and shall have filed the certificate of insurance or the certified copy of the insurance policy with the City. Each insurance policy shall contain a clause providing that it shall not be canceled by the insurance company without ten (10) days written notice to the City of intention to cancel. Each policy shall contain a provision that the City is not responsible to reimburse the insurer for any deductible amounts. The amounts of such insurance shall be not less than the following.

(1) Workmen's Compensation insurance in full compliance with the Illinois Workmen's Compensation Act and Employer's Liability coverage in the amount of not less than \$500,000.00

(2) Comprehensive General Liability

Bodily Injury	\$500,000.00	each occurrence
	\$500,000.00	aggregate
Property Damage	\$500,000.00	each occurrence
	\$500,000.00	aggregate

OR

\$1,000,000.00 Combined Single Limit

The Comprehensive General Liability shall be on the Comprehensive Form, including Premises-Operations, Explosion Collapse Hazard, Underground Hazard, Products/Completed Operations, Contractual Insurance, Broad Form Property Damage and Independent Contractors.

(3) Vehicle Liability

Bodily Injury	\$300,000.00	each person
	\$500,000.00	each accident
Property Damage	\$100,000.00	

OR

\$500,000.00 Combined
Single Limit

The Vehicle Liability must be on the Comprehensive Form and cover owned, hired and non-owned vehicles.

(4) Umbrella coverage in the amount of not less than \$1,000,000.

- I. COMPLIANCE WITH OTHER REGULATIONS: The Contractor shall be held solely responsible for compliance with other applicable City, County, State and Federal laws and regulations not specifically referenced within these documents. The Contractor is solely responsible for the safety of his employees in their work performance and of the worksite.
- J. STATEMENT OF REFERENCE: All prospective bidders submitting proposals to the City shall submit a separate list of references of clients for whom similar type of work has been performed within the last five (5) years, including contact person(s) and phone numbers.
- K. PREVAILING WAGE RATES: The successful bidder, and all his subcontractors, shall be required to pay not less than the prevailing rates of wages as determined in accordance with the Illinois Prevailing Wage Law to all laborers, craftsmen, journeymen, and other workers employed in the work necessitated by the fulfillment of this contract. Certified payroll is required with submission of all pay applications.

PART 2 SCOPE OF WORK:

- A. CIPP lining of multiple pipe segments (8"-10") totaling 2,354 linear feet.
- B. Open-cut replacement of segment MH174:MH133 per attached design documents (approximately 250 linear feet and 64 linear feet of highway crossing via jacking & boring method)
- C. Replacement of broken or dropped pipe segments (8"-12", approximately 140 linear feet)
- D. CIPP point repair of multiple pipe segments (8"-12") totaling approximately 37 linear feet
- E. Open-cut repair of laterals for approximately 22 connection points (broken or dropped laterals)
- F. Installation of 4 standard manholes (>6' deep)
- G. Removal & Replacement of one 4' diameter manhole (MH 132, 10'-15' deep)

PART 3 METHOD OF SELECTION:

- A. A selection committee of two City officials and the Engineer will review all proposals. Respondents will be ranked based on the following criteria.
 - 1. Understanding of project.
 - a. Price (per attached schedule)
 - b. Time schedule.
 - c. Project approach.

2. Submittals Required.
 - a. Bid Form
 - b. Schedule
 - c. Three references from recently completed projects of similar scope.

- B. The City, through its City Manager, reserves the right to reject all submissions that he/she determines do not meet the intent of these requirements and to waive defects in form or minor irregularities where the best interest of the City would be served.

- C. The City will issue a Notice of award immediately following approval by the City Council. The contractor will have two weeks to submit all remaining information, bonds, insurance, etc. The City will issue the Notice to Proceed once this information is obtained and reviewed.

PART 4 CANCELLATION OF SOLICITATION:

- A. The City retains the right to cancel this Solicitation at any time prior to the execution and approval of a Contract. If this Solicitation is canceled, all Submittals received in response to this RFP will be rejected. All package preparation costs remain the responsibility of the Proposer.

- B. Return of Information Package: The City shall be under no obligation to return any materials submitted by a Respondent in response to this RFP.

END OF SECTION

BID BOND

KNOW ALL MEN BY THESE PRESENTS, That we _____

(hereinafter called the Principal) and _____

(hereinafter called the Surety), a corporation chartered and existing under the laws of the State of _____ with its principal office in the City of _____ and authorized to do business in the State of Illinois are held and firmly bound unto the City of Mascoutah, IL, in the full and just sum of _____ Dollars (\$ _____) good and lawful money of the United States of America, to be paid upon demand of the City of Mascoutah, to which payment well and truly to be made, the Principal and the Surety bind themselves, their heirs, executors, administrators, and assigns, jointly and severally and firmly by the presents.

WHEREAS, the Principal is about to submit, or has submitted to the City of Mascoutah, a Bid for furnishing all labor, materials, equipment and incidentals necessary to perform, as described in these Contract Documents,

WHEREAS, the Contractor desires to file this bond in accordance with law, in lieu of a certified bidder's check otherwise required to accompany this Bid.

NOW, THEREFORE: The conditions of this obligation are such that if the Bid is accepted, the Principal shall, within ten (10) days after the date of receipt of a written notice of award of contract, execute a contract in accordance with the Bid and upon the terms, conditions and price(s) set forth therein, of form and manner required by the City of Mascoutah, and execute a sufficient and satisfactory contract Performance Bond, Labor and Material Bond, and Maintenance Bond, each payable to the City of Mascoutah, in an amount of One Hundred Percent (100%) of the total Contract price in form and with security satisfactory to said City of Mascoutah, then this obligation to be void; otherwise to be and remain in full force and virtue in law; and the Surety shall, upon failure of the Principal to comply with any or all of the foregoing requirements within the time specified above, immediately pay to the aforesaid City of Mascoutah, upon demand, the amount hereof in good and lawful money of the United States of America not as a penalty but as liquidated damages.

Surety companies executing Bonds must hold Certificates of Authority as Acceptable Sureties, must appear on the Treasury Department's most current list "A" Rating or better (Circular 570 as amended), and be authorized to transact business in the State of Illinois.

IN TESTIMONY THEREOF, the Principal and Surety have caused these presents to be duly signed and sealed this _____ day of _____, 2020.

PRINCIPAL

By _____
(Seal)

Surety

(Seal)

Countersigned _____

Local Resident Producing Agent for _____

CITY OF MASCOUTAH, IL

BID FORM

SANITARY SEWER REHABILITATION PHASE I

Name of Bidder _____

Business Address _____

Date _____

To: The City of Mascoutah, IL

The undersigned, as Bidder, declares that the only person or parties interested in this Bid as principals are those named herein; that this Bid is made without collusion with any person, firm or corporation; that he has carefully examined the location of the proposed work, the proposed forms of Agreement and Bonds, and the Contract Drawings and Specifications for the above designated work, all other documents referred to or mentioned in the Contract Documents, the Contract Drawings and Specifications, including Addenda Nos. 1, _____, _____, and issued thereto; and he proposes and agrees if this bid is accepted that he will contract with the City of Mascoutah, IL, in the form of the copy of the Agreement included in these Contract Documents, to provide all necessary machinery, tools, apparatus, and other means of construction, including utility and transportation services necessary to do all the work and furnish all materials and equipment specified or referred to in the Contract Documents, in the manner and time therein prescribed and according to the requirements of the City of Mascoutah, IL as therein set forth to furnish the Contractor's Bonds and Insurance, and to do all other things required of the Contractor by the Contract Documents, and that he will take in full payment therefore the sums set forth in the following Bid Schedule.

I. BID SCHEDULE

Bidder agrees to perform all the work described in the Contract Document for the following unit prices.

Bids shall include all applicable taxes.

SANITARY SEWER REHABILITATION PHASE I (BASE BID)

PAY ITEM	APPROXIMATE QUANTITY	DESCRIPTION OF ITEMS WITH BID PRICES WRITTEN IN WORDS	UNIT PRICE	AMOUNT BID
-------------	-------------------------	--	---------------	---------------

(Furnish and install, including all appurtenant work, complete in place, the following items:)

1	1 LS	Remove 8" VCP and replace with 8" PVC, (broken or dropped sewer mains as shown in exhibits – approx. 50 LF, Per Section SP-3)		

		_____ Dollars &		
		_____ Cents per <u>LS</u>	\$ _____	\$ _____

2	1 LS	Remove 12" VCP and replace with 12" PVC, (broken or dropped sewer mains as shown in exhibits – approx. 90 LF), Per Section SP-3)		

		_____ Dollars &		
		_____ Cents per <u>LS</u>	\$ _____	\$ _____

3	250 LF	Remove and replace segment between MH174:MH133 via open-cut method per drawings and Section D2-13 (Removal and Disposal of Existing Pipe, Cost of Traffic Control & Bypass Pumping, abandonment of existing sewer segment crossing highway and MH133 per Section D2-11 , Pavement repair as shown in drawings per Section D2- 17 Included)		

		_____ Dollars &		
		_____ Cents per <u>LF</u>	\$ _____	\$ _____

PAY ITEM	APPROXIMATE QUANTITY	DESCRIPTION OF ITEMS WITH BID PRICES WRITTEN IN WORDS	UNIT PRICE	AMOUNT BID
4	64 LF	West Main Street Crossing via Jack & Bore method (using 20" diameter steel casing, Per Section D2-23)		

		_____ Dollars &		
		_____ Cents per <u>LF</u>	\$ _____	\$ _____
5	4 EA	Install 4-ft diameter standard sanitary sewer manhole (>6' deep) per Section D2-6.		

		_____ Dollars &		
		_____ Cents per <u>EA</u>	\$ _____	\$ _____
6	2,166 LF	Cured-In-Place-Pipe (8") CIPP Per Section D2-12 (Cost of Traffic Control & Bypass Pumping Included)		

		_____ Dollars &		
		_____ Cents per <u>LF</u>		
			\$ _____	\$ _____

PAY ITEM	APPROXIMATE QUANTITY	DESCRIPTION OF ITEMS WITH BID PRICES WRITTEN IN WORDS	UNIT PRICE	AMOUNT BID
7	188 LF	Cured-In-Place-Pipe (10") CIPP Per Section D2-12 (Cost of Traffic Control & Bypass Pumping Included)		
		<hr/> Dollars & <hr/> Cents per <u>LF</u>	\$ _____	\$ _____
8	1 LS	CIPP point repair of segments (approximately 27 linear feet of 8" and 10 linear feet of 12") Per Section SP-1		
		<hr/> Dollars & <hr/> Cents per <u>LS</u>	\$ _____	\$ _____
9	22 EA	Open-cut repair of Laterals (dropped or broken laterals) Per Section SP-3		
		<hr/> Dollars & <hr/> Cents per <u>EA</u>	\$ _____	\$ _____

10 **1 EA** Remove and Replace MH132 (4' diameter,
10'-15' deep) per Section D2-5

_____ Dollars &

_____ Cents per EA \$ _____ \$ _____

11 **65 EA** Lateral reinstatement per Section SP-4

_____ Dollars &

_____ Cents per EA \$ _____ \$ _____

12 **7 EA** Cut protruding taps per Section SP-2

_____ Dollars &

_____ Cents per EA \$ _____ \$ _____

13 **1 LS** Video Documentation of Surface Conditions
per Section D1-3

_____ Dollars &

_____ Cents per LS \$ _____ \$ _____

14

1 LS

Mobilization: 5% (maximum) of total base bid per Section D2-20. 50% of this item will be paid for Mobilization. The other 50% will be paid upon De-Mobilization.

_____ Dollars &
_____ Cents per LS \$ _____ \$ _____

TOTAL BASE BID – ITEMS 1-14 \$ _____

(in writing)

II. BID CONDITIONS

It is expressly understood and agreed that the preceding total Bid is the basis for establishing the amount of the Bid security on this Bid for **SANITARY SEWER REHABILITATION PHASE I** for the **CITY OF MASCOUTAH, IL**, and that this total Bid is not to be construed to be a Lump Sum Bid.

It is further understood that quantities in the bidding schedule for unit price items are approximate only, and that payment of a Contract will be made only on the actual quantities of work completed in place, measured on the basis defined in the General Conditions, Specifications, or other Contract Documents.

There shall be no measurement or separate payment for any items not listed and all costs pertaining thereto shall be included in the unit prices for other items listed in the Proposal.

The undersigned has carefully checked the above bidding schedule against the Contract Drawings, Specifications, and other Contract Documents before preparing this Bid and accepts the said quantities to be substantially correct, both as to classification and amount, and as correctly listing the complete work to be done in accordance with the Contract Drawings, Specifications, and other Contract Documents.

If this Bid is accepted and the undersigned shall fail to contract as aforesaid and to give the Performance Bond, Labor and Material Bond, and Maintenance Bond required by the Conditions of Contract or by law, and to provide all insurance as required by the Contract Documents within ten (10) days after the date of the notice of award of the Contract, the City of Mascoutah, IL may, at his option, determine that the Bidder has abandoned his Contract, and thereupon this proposal and the acceptance thereof shall be null and void, and the forfeiture of such security accompanying this proposal shall operate and the same shall be the property of the City of Mascoutah as liquidated damages.

The undersigned agrees to fully complete all work covered by this Bid to the point of final acceptance by the City of Mascoutah no later than **90 Calendar Days from date of Notice to Proceed**.

By submission of this Bid, the undersigned certifies, and in the case of a joint bid, each party thereto certifies as to his own organization, that in connection with the proposal:

- A. The prices in the proposal have been arrived at independently, without consultation, communication, or agreement, for the purpose of restricting competition, as to any matter relating to such prices with any other bidder or with any competitor;
- B. Unless otherwise required by law, the prices which have been quoted in the bid have not knowingly been disclosed by the Bidder prior to opening, directly or indirectly to any other Bidder or to any competitor; and,
- C. No attempt has been made or will be made by the Bidder to induce any other person or firm to submit or not submit a bid for the purpose of restricting competition.
- D. He is the person in the Bidder's organization responsible within that organization for the decision as to the prices being bid and shall also certify that he has not participated, and will not participate in any action contrary to Paragraphs A through C above.
- E. He is not the person in the Bidder's organization responsible within that organization for the decision as to the prices being bid but that he has been authorized to act as agent for the persons responsible for such decision in certifying that such persons have not participated, and will not participate, in any action contrary to Paragraphs A through C above, and as their agent shall so certify; and shall also certify that he has not participated, and will not participate in any action contrary to Paragraphs A through C above.

III. BID SECURITY

Accompanying this Bid is a _____ in the amount of _____
_____ Dollars. (\$ _____)

Note: The total amount of Bid security shall be based on the Total Bid of this Contract.

IV. BIDDER'S SIGNATURE

A. An Individual

By _____ (SEAL)
(Individual's Name)

doing business as _____

Business address: _____

Phone No.: _____

B. A Partnership

By _____ (SEAL)
(Firm Name)

_____ (General Partner)

Business address: _____

Phone No.: _____

C. A Corporation

By _____
(Corporation Name)

(State of Incorporation)

By _____
(Name of Person Authorized to Sign)

(Title)

(Corporate Seal)

Attest _____
(Secretary)

Business address: _____

Phone No.: _____

D. A Joint Venture

By _____
(Name)

(Address)

By _____
(Name)

(Address)

(Each joint venturer must sign. The manner of signing for each individual, partnership and corporation that is a party to the joint venture should be in the manner indicated above).

Subscribed and sworn to before me this _____ day of _____, 2021.

Notary Public

SUBCONTRACTORS

List of Major Subcontractors

The Bidder expressly agrees that:

1. If awarded a Contract as a result of this Bid, the major subcontractors used in the prosecution of the work will be those listed below, and
2. The following list includes all subcontractors who will perform work on this contract.
3. The Bidder represents that the subcontractors listed below are financially responsible and are qualified to perform the work required.

<u>Category</u>	<u>Name of Subcontractor</u>	<u>Address</u>	<u>Meets Qualifications</u>

**FORM OF AGREEMENT
BETWEEN OWNER AND CONTRACTOR
FOR CONSTRUCTION CONTRACT**

This Agreement is by and between City of Mascoutah, Illinois (“Owner”) and _____ (“Contractor”).

Owner and Contractor hereby agree as follows:

ARTICLE 1 – WORK

1.01 Contractor shall complete all Work as specified or indicated in the Contract Documents. The Work is generally described as follows:

Furnishing all labor, equipment, material, supplies, permits and fees required for the rehabilitation of various sizes of sanitary sewer mains via CIPP lining, open-cut repair and CIPP point repair methods, removal and replacement of approximately 314 linear feet of 10-inch vitrified clay sanitary sewer gravity main by the open-cut trench and jacking and boring method, installation of four standard sanitary sewer manholes, removal and replacement of an existing sanitary sewer manhole, rehabilitation of approximately twenty-two lateral to main connections via open-cut repair method (all incidental work to these items) as shown on the Plans, Exhibits and in accordance with the Contract Documents.

ARTICLE 2 – THE PROJECT

2.01 The Project for which the Work under the Contract Documents may be the whole or only a part is generally described as follows:

Sanitary Sewer Rehabilitation Project – Phase I

ARTICLE 3 – ENGINEER

3.01 The Project has been designed by RJN Group Inc.(Engineer), which is to act as Owner’s representative, assume all duties and responsibilities, and have the rights and authority assigned to Engineer in the Contract Documents in connection with the completion of the Work in accordance with the Contract Documents.

ARTICLE 4 – CONTRACT TIMES

4.01 *Time of the Essence*

A. All time limits for Milestones, if any, Substantial Completion, and completion and readiness for final payment as stated in the Contract Documents are of the essence of the Contract.

4.02 *Days to Achieve Substantial Completion and Final Payment*

- A. The Work will be substantially completed within 75 days after the date when the Contract Times commence to run as provided in Paragraph 2.03 of the General Conditions and completed and ready for final payment in accordance with Paragraph 14.07 of the General Conditions within 90 days after the date when the Contract Times commence to run.

4.03 *Liquidated Damages*

- A. Contractor and Owner recognize that time is of the essence as stated in Paragraph 4.01 above and that Owner will suffer financial loss if the Work is not completed within the times specified in Paragraph 4.02 above, plus any extensions thereof allowed in accordance with Article 12 of the General Conditions. The parties also recognize the delays, expense, and difficulties involved in proving in a legal or arbitration proceeding the actual loss suffered by Owner if the Work is not completed on time. Accordingly, instead of requiring any such proof, Owner and Contractor agree that as liquidated damages for delay (but not as a penalty), Contractor shall pay Owner \$500 for each day that expires after the time specified in Paragraph 4.02 above for Substantial Completion until the Work is substantially complete. After Substantial Completion, if Contractor shall neglect, refuse, or fail to complete the remaining Work within the Contract Time or any proper extension thereof granted by Owner, Contractor shall pay Owner \$500 for each day that expires after the time specified in Paragraph 4.02 above for completion and readiness for final payment until the Work is completed and ready for final payment.

ARTICLE 5 – CONTRACT PRICE

- 5.02 Owner shall pay Contractor for completion of the Work in accordance with the Contract Documents an amount in current funds equal to the sum of the amounts determined pursuant to Paragraphs 5.02.A, 5.02.B, and 5.02.C below:

- A. For all Work other than Unit Price Work, a lump sum of: \$ _____

All specific cash allowances are included in the above price in accordance with Paragraph 11.02 of the General Conditions.

- B. For all Unit Price Work, an amount equal to the sum of the established unit price for each separately identified item of Unit Price Work times the actual quantity of that item:

UNIT PRICE WORK					
Item No.	Description	Unit	Estimated Quantity	Bid Unit Price	Bid Price
1	Remove 8" VCP and replace with 8" PVC (approx.. 50LF)	LS	1	\$	\$
2	Remove 12" VCP and replace with 12" PVC (approx. 90 LF)	LS	1	\$	\$

3	Remove and replace segment between MH174:MH133 via open-cut method (Removal and Disposal of Existing Pipe, Cost of Traffic Control & Bypass Pumping, abandonment of existing sewer segment crossing highway and MH133, Pavement repair Included)	LF	250	\$	\$
4	West Main Street Crossing via Jack & Bore method (using 20" diameter steel casing)	LF	64	\$	\$
5	Install 4-ft diameter standard sanitary sewer manhole (>6' deep)	EA	4	\$	\$
6	Cured-In-Place-Pipe (8") CIPP (Cost of Traffic Control & Bypass Pumping Included)	LF	2,166	\$	\$
7	Cured-In-Place-Pipe (10") CIPP (Cost of Traffic Control & Bypass Pumping Included)	LF	188	\$	\$
8	CIPP point repair of segments (approximately 27 linear feet of 8" and 10 linear feet of 12")	LS	1	\$	\$
9	Open-cut repair of Laterals (dropped or broken laterals)	EA	22	\$	\$
10	Remove and Replace MH132 (4' diameter, 10'-15' deep, all necessary work included)	EA	1	\$	\$
11	Lateral Reinstatements	EA	65	\$	\$
12	Cut Protruding Taps	EA	7	\$	\$
13	Video Documentation of Surface Conditions	LS	1	\$	\$
14	Mobilization: 5% (maximum) of total base bid. 50% of this item will be paid for Mobilization, the other 50% will be paid upon De-Mobilization	LS	1	\$	\$
Total of All Bid Prices – Base				\$	

Total of All Bid Prices - Base (Words): _____

The Bid prices for Unit Price Work set forth as of the Effective Date of the Agreement are based on estimated quantities. As provided in Paragraph 11.05 of the General Conditions, estimated quantities are not guaranteed, and determinations of actual quantities and classifications are to be made by Engineer as provided in Paragraph 9.08 of the General Conditions.

C. For all Work, at the prices stated in Contractor's Bid, attached hereto as an exhibit.

ARTICLE 6 – PAYMENT PROCEDURES

6.01 Submittal and Processing of Payments

A. Contractor shall submit Applications for Payment in accordance with Article 14 of the General Conditions. Applications for Payment will be processed by Engineer as provided in the General Conditions.

6.02 Progress Payments; Retainage

A. Owner shall make progress payments on account of the Contract Price on the basis of Contractor's Applications for Payment on or about the 15th day of each month during performance of the Work as provided in Paragraph 6.02.A.1 below. All such payments will be measured by the schedule of values established as provided in Paragraph 2.07.A of the General Conditions (and in the case of Unit Price Work based on the number of units completed) or, in the event there is no schedule of values, as provided in the General Requirements.

1. Prior to Substantial Completion, progress payments will be made in an amount equal to the percentage indicated below but, in each case, less the aggregate of payments previously made and less such amounts as Engineer may determine or Owner may withhold, including but not limited to liquidated damages, in accordance with Paragraph 14.02 of the General Conditions.

a. 95 percent of Work completed (with the balance being retainage); and

b. 95 percent of cost of materials and equipment not incorporated in the Work (with the balance being retainage).

B. Upon Substantial Completion, Owner shall pay an amount sufficient to increase total payments to Contractor to 100 percent of the Work completed, less such amounts as Engineer shall determine in accordance with Paragraph 14.05.B of the General Conditions and less 200 percent of Engineer's estimate of the value of Work to be completed or corrected as shown on the tentative list of items to be completed or corrected attached to the certificate of Substantial Completion.

6.03 Final Payment

A. Upon final completion and acceptance of the Work in accordance with Paragraph 14.07 of the General Conditions, Owner shall pay the remainder of the Contract Price as recommended by Engineer as provided in said Paragraph 14.07.

ARTICLE 7 – INTEREST

7.01 All moneys not paid when due as provided in Article 14 of the General Conditions shall bear interest at the rate of 0.00 percent per annum.

ARTICLE 8 – CONTRACTOR’S REPRESENTATIONS

8.01 In order to induce Owner to enter into this Agreement, Contractor makes the following representations:

- A. Contractor has examined and carefully studied the Contract Documents and the other related data identified in the Bidding Documents.
- B. Contractor has visited the Site and become familiar with and is satisfied as to the general, local, and Site conditions that may affect cost, progress, and performance of the Work.
- C. Contractor is familiar with and is satisfied as to all federal, state, and local Laws and Regulations that may affect cost, progress, and performance of the Work.
- D. Contractor has carefully studied all: (1) reports of explorations and tests of subsurface conditions at or contiguous to the Site and all drawings of physical conditions relating to existing surface or subsurface structures at the Site (except Underground Facilities), as containing reliable "technical data," and (2) reports and drawings of Hazardous Environmental Conditions, if any, at the Site as containing reliable "technical data."
- E. Contractor has considered the information known to Contractor; information commonly known to contractors doing business in the locality of the Site; information and observations obtained from visits to the Site; the Contract Documents; and the Site-related reports and drawings identified in the Contract Documents, with respect to the effect of such information, observations, and documents on (1) the cost, progress, and performance of the Work; (2) the means, methods, techniques, sequences, and procedures of construction to be employed by Contractor, including any specific means, methods, techniques, sequences, and procedures of construction expressly required by the Contract Documents; and (3) Contractor’s safety precautions and programs.
- F. Based on the information and observations referred to in Paragraph 8.01.E above, Contractor does not consider that further examinations, investigations, explorations, tests, studies, or data are necessary for the performance of the Work at the Contract Price, within the Contract Times, and in accordance with the other terms and conditions of the Contract Documents.
- G. Contractor is aware of the general nature of work to be performed by Owner and others at the Site that relates to the Work as indicated in the Contract Documents.
- H. Contractor has given Engineer written notice of all conflicts, errors, ambiguities, or discrepancies that Contractor has discovered in the Contract Documents, and the written resolution thereof by Engineer is acceptable to Contractor.

- I. The Contract Documents are generally sufficient to indicate and convey understanding of all terms and conditions for performance and furnishing of the Work.

ARTICLE 9 – CONTRACT DOCUMENTS

9.01 *Contents*

- A. The Contract Documents consist of the following:
 1. This Agreement (pages 1 to 9, inclusive);
 2. Performance bond (pages 1 to 3, inclusive);
 3. Payment bond (pages 1 to 3, inclusive);
 4. State Requirements; if any,
 5. Specifications as listed in the table of contents of the Project Specifications Book;
 6. Job Special Provisions as listed in the table of contents of the Project Specifications Book;
 7. Drawings consisting of 6 sheets with each sheet bearing the following general title: MASCOUTAH SANITARY SEWER REHABILITATION, PHASE I
 8. Rehabilitation Exhibits as listed in the table of contents of the Project Specifications Book I
 9. Addenda (numbers _____ to _____, inclusive);
 10. Exhibits to this Agreement (enumerated as follows):
 - a. Contractor’s Bid;
 - b. Documentation submitted by Contractor prior to Notice of Award;
 11. The following which may be delivered or issued on or after the Effective Date of the Agreement and are not attached hereto:
 - a. Notice to Proceed;
 - b. Work Change Directives;
 - c. Change Orders; and
 - d. Affidavit – Compliance with Prevailing Wage Law.
- B. The documents listed in Paragraph 9.01.A are attached to this Agreement (except as expressly noted otherwise above).
- C. There are no Contract Documents other than those listed above in this Article 9.

- D. The Contract Documents may only be amended, modified, or supplemented as provided in Paragraph 3.02 of the General Conditions.

ARTICLE 10 – MISCELLANEOUS

10.01 *Terms*

- A. Terms used in this Agreement will have the meanings stated in the General Conditions.

10.02 *Assignment of Contract*

- A. No assignment by a party hereto of any rights under or interests in the Contract will be binding on another party hereto without the written consent of the party sought to be bound; and, specifically but without limitation, moneys that may become due and moneys that are due may not be assigned without such consent (except to the extent that the effect of this restriction may be limited by law), and unless specifically stated to the contrary in any written consent to an assignment, no assignment will release or discharge the assignor from any duty or responsibility under the Contract Documents.

10.03 *Successors and Assigns*

- A. Owner and Contractor each binds itself, its partners, successors, assigns, and legal representatives to the other party hereto, its partners, successors, assigns, and legal representatives in respect to all covenants, agreements, and obligations contained in the Contract Documents.

10.04 *Severability*

- A. Any provision or part of the Contract Documents held to be void or unenforceable under any Law or Regulation shall be deemed stricken, and all remaining provisions shall continue to be valid and binding upon Owner and Contractor, who agree that the Contract Documents shall be reformed to replace such stricken provision or part thereof with a valid and enforceable provision that comes as close as possible to expressing the intention of the stricken provision.

10.05 *Contractor's Certifications*

- A. Contractor certifies that it has not engaged in corrupt, fraudulent, collusive, or coercive practices in competing for or in executing the Contract. For the purposes of this Paragraph 10.05:
1. "corrupt practice" means the offering, giving, receiving, or soliciting of any thing of value likely to influence the action of a public official in the bidding process or in the Contract execution;
 2. "fraudulent practice" means an intentional misrepresentation of facts made (a) to influence the bidding process or the execution of the Contract to the detriment of Owner, (b) to establish Bid or Contract prices at artificial non-competitive levels, or (c) to deprive Owner of the benefits of free and open competition;

3. “collusive practice” means a scheme or arrangement between two or more Bidders, with or without the knowledge of Owner, a purpose of which is to establish Bid prices at artificial, non-competitive levels; and
4. “coercive practice” means harming or threatening to harm, directly or indirectly, persons or their property to influence their participation in the bidding process or affect the execution of the Contract.

Remainder of Page Intentionally Left Blank

IN WITNESS WHEREOF, Owner and Contractor have signed this Agreement. Counterparts have been delivered to Owner and Contractor. All portions of the Contract Documents have been signed or have been identified by Owner and Contractor or on their behalf.

This Agreement will be effective on _____(which is the Effective Date of the Agreement).

OWNER:
The City of Mascoutah, Mascoutah, Illinois

CONTRACTOR:
Signature: _____

Signature: _____

Name: _____

Name: _____

Title: _____

Title: _____

[CORPORATE SEAL]

[CORPORATE SEAL]

Attest: _____
Melissa Schanz, City Clerk

Attest: _____

Address for giving notices:
Office of the City Clerk
#3 West Main Street
Mascoutah, Illinois 62258

Address for giving notices:

License No.: _____

(If Owner is a corporation, attach evidence of authority to sign. If Owner is a public body, attach evidence of authority to sign and resolution or other documents authorizing execution of this Agreement.)

(If Contractor is a corporation, a partnership, or a joint venture, attach evidence of authority to sign.)

Agent for service of process:

Designated Representative:
Name: _____
Title: _____
Address: #3 West Main Street
Mascoutah, Illinois 62258
Phone: (618) 566-2964
Fax: _____

Designated Representative:
Name: _____
Title: _____
Address: _____
Phone: _____
Fax: _____

PERFORMANCE BOND

Any singular reference to Contractor, Surety, Owner, or other party shall be considered plural where applicable.

CONTRACTOR (*Name and Address*): SURETY (*Name, and Address of Principal Place of Business*):

OWNER (*Name and Address*):
City of Mascoutah
#3 West Main Street
Mascoutah, Illinois 62258

CONTRACT
Effective Date of Agreement:
Amount:
Description (*Name and Location*):

BOND
Bond Number:
Date (*Not earlier than Effective Date of Agreement*):
Amount:
Modifications to this Bond Form:

Surety and Contractor, intending to be legally bound hereby, subject to the terms set forth below, do each cause this Performance Bond to be duly executed by an authorized officer, agent, or representative.

CONTRACTOR AS PRINCIPAL

SURETY

Contractor's Name and Corporate Seal (Seal)

Surety's Name and Corporate Seal (Seal)

By: _____
Signature

By: _____
Signature (Attach Power of Attorney)

Print Name

Print Name

Title

Title

Attest: _____
Signature

Attest: _____
Signature

Title

Title

Note: Provide execution by additional parties, such as joint venturers, if necessary.

Contractor and Surety, jointly and severally, bind themselves, their heirs, executors, administrators, successors, and assigns to Owner for the performance of the Contract, which is incorporated herein by reference.

1. If Contractor performs the Contract, Surety and Contractor have no obligation under this Bond, except to participate in conferences as provided in Paragraph 2.1.
2. If there is no Owner Default, Surety's obligation under this Bond shall arise after:
 - 2.1 Owner has notified Contractor and Surety, at the addresses described in Paragraph 9 below, that Owner is considering declaring a Contractor Default and has requested and attempted to arrange a conference with Contractor and Surety to be held not later than 15 days after receipt of such notice to discuss methods of performing the Contract. If Owner, Contractor, and Surety agree, Contractor shall be allowed a reasonable time to perform the Contract, but such an agreement shall not waive Owner's right, if any, subsequently to declare a Contractor Default; and
 - 2.2 Owner has declared a Contractor Default and formally terminated Contractor's right to complete the Contract. Such Contractor Default shall not be declared earlier than 20 days after Contractor and Surety have received notice as provided in Paragraph 2.1; and
 - 2.3 Owner has agreed to pay the Balance of the Contract Price to:
 1. Surety in accordance with the terms of the Contract; or
 2. Another contractor selected pursuant to Paragraph 3.3 to perform the Contract.
3. When Owner has satisfied the conditions of Paragraph 2, Surety shall promptly, and at Surety's expense, take one of the following actions:
 - 3.1 Arrange for Contractor, with consent of Owner, to perform and complete the Contract; or
 - 3.2 Undertake to perform and complete the Contract itself, through its agents or through independent contractors; or
 - 3.3 Obtain bids or negotiated proposals from qualified contractors acceptable to Owner for a contract for performance and completion of the Contract, arrange for a contract to be prepared for execution by Owner and contractor selected with Owner's concurrence, to be secured with performance and payment bonds executed by a qualified surety equivalent to the bonds issued on the Contract, and pay to Owner the amount of damages as described in Paragraph 5 in excess of the Balance of the Contract Price incurred by Owner resulting from Contractor Default; or
 - 3.4 Waive its right to perform and complete, arrange for completion, or obtain a new contractor, and with reasonable promptness under the circumstances:
 1. After investigation, determine the amount for which it may be liable to Owner and, as soon as practicable after the amount is determined, tender payment therefor to Owner; or
 2. Deny liability in whole or in part and notify Owner citing reasons therefor.
4. If Surety does not proceed as provided in Paragraph 3 with reasonable promptness, Surety shall be deemed to be in default on this Bond 15 days after receipt of an additional written notice from Owner to Surety demanding that Surety perform its obligations under this Bond, and Owner shall be entitled to enforce any remedy available to Owner. If Surety proceeds as provided in Paragraph 3.4, and Owner refuses the payment tendered or Surety has denied liability, in whole or in part, without further notice Owner shall be entitled to enforce any remedy available to Owner.
5. After Owner has terminated Contractor's right to complete the Contract, and if Surety elects to act under Paragraph 3.1, 3.2, or 3.3 above, then the responsibilities of Surety to Owner shall not be greater than those of Contractor under the Contract, and the responsibilities of Owner to Surety shall not be greater than those of Owner under the Contract. To the limit of the amount of this Bond, but subject to commitment by Owner of the Balance of the Contract Price to mitigation of costs and damages on the Contract, Surety is obligated without duplication for:

- 5.1 The responsibilities of Contractor for correction of defective Work and completion of the Contract;
- 5.2 Additional legal, design professional, and delay costs resulting from Contractor's Default, and resulting from the actions of or failure to act of Surety under Paragraph 3; and
- 5.3 Liquidated damages, or if no liquidated damages are specified in the Contract, actual damages caused by delayed performance or non-performance of Contractor.

6. Surety shall not be liable to Owner or others for obligations of Contractor that are unrelated to the Contract, and the Balance of the Contract Price shall not be reduced or set off on account of any such unrelated obligations. No right of action shall accrue on this Bond to any person or entity other than Owner or its heirs, executors, administrators, or successors.

7. Surety hereby waives notice of any change, including changes of time, to Contract or to related subcontracts, purchase orders, and other obligations.

8. Any proceeding, legal or equitable, under this Bond may be instituted in any court of competent jurisdiction in the location in which the Work or part of the Work is located, and shall be instituted within two years after Contractor Default or within two years after Contractor ceased working or within two years after Surety refuses or fails to perform its obligations under this Bond, whichever occurs first. If the provisions of this paragraph are void or prohibited by law, the minimum period of limitation available to sureties as a defense in the jurisdiction of the suit shall be applicable.

9. Notice to Surety, Owner, or Contractor shall be mailed or delivered to the address shown on the signature page.

10. When this Bond has been furnished to comply with a statutory requirement in the location where the Contract was to be performed, any provision in this Bond conflicting with said statutory requirement shall be deemed deleted herefrom and provisions conforming to such statutory requirement shall be deemed incorporated herein. The intent is that this Bond shall be construed as a statutory bond and not as a common law bond.

11. Definitions.

- 11.1 Balance of the Contract Price: The total amount payable by Owner to Contractor under the Contract after all proper adjustments have been made, including allowance to Contractor of any amounts received or to be received by Owner in settlement of insurance or other Claims for damages to which Contractor is entitled, reduced by all valid and proper payments made to or on behalf of Contractor under the Contract.
- 11.2 Contract: The agreement between Owner and Contractor identified on the signature page, including all Contract Documents and changes thereto.
- 11.3 Contractor Default: Failure of Contractor, which has neither been remedied nor waived, to perform or otherwise to comply with the terms of the Contract.
- 11.4 Owner Default: Failure of Owner, which has neither been remedied nor waived, to pay Contractor as required by the Contract or to perform and complete or otherwise comply with the other terms thereof.

FOR INFORMATION ONLY – <i>(Name, Address and Telephone)</i> Surety Agency or Broker: Owner's Representative <i>(Engineer or other party)</i> :
--

PAYMENT BOND

Any singular reference to Contractor, Surety, Owner, or other party shall be considered plural where applicable.

CONTRACTOR (*Name and Address*):

SURETY (*Name, and Address of Principal Place of Business*):

OWNER (*Name and Address*):

City of Mascoutah
#3 West Main Street
Mascoutah, Illinois 62258

CONTRACT

Effective Date of Agreement:
Amount:
Description (*Name and Location*):

BOND

Bond Number:
Date (*Not earlier than Effective Date of Agreement*):
Amount:
Modifications to this Bond Form:

Surety and Contractor, intending to be legally bound hereby, subject to the terms set forth below, do each cause this Payment Bond to be duly executed by an authorized officer, agent, or representative.

CONTRACTOR AS PRINCIPAL

SURETY

Contractor's Name and Corporate Seal (Seal)

Surety's Name and Corporate Seal (Seal)

By: _____
Signature

By: _____
Signature (Attach Power of Attorney)

Print Name

Print Name

Title

Title

Attest: _____
Signature

Attest: _____
Signature

Title

Title

Note: Provide execution by additional parties, such as joint venturers, if necessary.

1. Contractor and Surety, jointly and severally, bind themselves, their heirs, executors, administrators, successors, and assigns to Owner to pay for labor, materials, and equipment furnished by Claimants for use in the performance of the Contract, which is incorporated herein by reference.
2. With respect to Owner, this obligation shall be null and void if Contractor:
 - 2.1 Promptly makes payment, directly or indirectly, for all sums due Claimants, and
 - 2.2 Defends, indemnifies, and holds harmless Owner from all claims, demands, liens, or suits alleging non-payment by Contractor by any person or entity who furnished labor, materials, or equipment for use in the performance of the Contract, provided Owner has promptly notified Contractor and Surety (at the addresses described in Paragraph 12) of any claims, demands, liens, or suits and tendered defense of such claims, demands, liens, or suits to Contractor and Surety, and provided there is no Owner Default.
3. With respect to Claimants, this obligation shall be null and void if Contractor promptly makes payment, directly or indirectly, for all sums due.
4. Surety shall have no obligation to Claimants under this Bond until:
 - 4.1 Claimants who are employed by or have a direct contract with Contractor have given notice to Surety (at the address described in Paragraph 12) and sent a copy, or notice thereof, to Owner, stating that a claim is being made under this Bond and, with substantial accuracy, the amount of the claim.
 - 4.2 Claimants who do not have a direct contract with Contractor:
 1. Have furnished written notice to Contractor and sent a copy, or notice thereof, to Owner, within 90 days after having last performed labor or last furnished materials or equipment included in the claim stating, with substantial accuracy, the amount of the claim and the name of the party to whom the materials or equipment were furnished or supplied, or for whom the labor was done or performed; and
 2. Have either received a rejection in whole or in part from Contractor, or not received within 30 days of furnishing the above notice any communication from Contractor by which Contractor had indicated the claim will be paid directly or indirectly; and
 3. Not having been paid within the above 30 days, have sent a written notice to Surety (at the address described in Paragraph 12) and sent a copy, or notice thereof, to Owner, stating that a claim is being made under this Bond and enclosing a copy of the previous written notice furnished to Contractor.
5. If a notice by a Claimant required by Paragraph 4 is provided by Owner to Contractor or to Surety, that is sufficient compliance.
6. Reserved.
7. Surety's total obligation shall not exceed the amount of this Bond, and the amount of this Bond shall be credited for any payments made in good faith by Surety.
8. Amounts owed by Owner to Contractor under the Contract shall be used for the performance of the Contract and to satisfy claims, if any, under any performance bond. By Contractor furnishing and Owner accepting this Bond, they agree that all funds earned by Contractor in the performance of the Contract are dedicated to satisfy obligations of Contractor and Surety under this Bond, subject to Owner's priority to use the funds for the completion of the Work.
9. Surety shall not be liable to Owner, Claimants, or others for obligations of Contractor that are unrelated to the Contract. Owner shall not be liable for payment of any costs or expenses of any Claimant under this Bond, and shall have under this Bond no obligations to make payments to, give notices on behalf of, or otherwise have obligations to Claimants under this Bond.

10. Surety hereby waives notice of any change, including changes of time, to the Contract or to related subcontracts, purchase orders, and other obligations.

11. No suit or action shall be commenced by a Claimant under this Bond other than in a court of competent jurisdiction in the location in which the Work or part of the Work is located or after the expiration of one year from the date (1) on which the Claimant gave the notice required by Paragraph 4.1 or Paragraph 4.2.3, or (2) on which the last labor or service was performed by anyone or the last materials or equipment were furnished by anyone under the Contract, whichever of (1) or (2) first occurs. If the provisions of this paragraph are void or prohibited by law, the minimum period of limitation available to sureties as a defense in the jurisdiction of the suit shall be applicable.

12. Notice to Surety, Owner, or Contractor shall be mailed or delivered to the addresses shown on the signature page. Actual receipt of notice by Surety, Owner, or Contractor, however accomplished, shall be sufficient compliance as of the date received at the address shown on the signature page.

13. When this Bond has been furnished to comply with a statutory requirement in the location where the Contract was to be performed, any provision in this Bond conflicting with said statutory requirement shall be deemed deleted herefrom and provisions conforming to such statutory requirement shall be deemed incorporated herein. The intent is that this Bond shall be construed as a statutory Bond and not as a common law bond.

14. Upon request of any person or entity appearing to be a potential beneficiary of this Bond, Contractor shall promptly furnish a copy of this Bond or shall permit a copy to be made.

15. Definitions

15.1 Claimant: An individual or entity having a direct contract with Contractor, or with a first-tier subcontractor of Contractor, to furnish labor, materials, or equipment for use in the performance of the Contract. The intent of this Bond shall be to include without limitation in the terms “labor, materials or equipment” that part of water, gas, power, light, heat, oil, gasoline, telephone service, or rental equipment used in the Contract, architectural and engineering services required for performance of the Work of Contractor and Contractor’s subcontractors, and all other items for which a mechanic’s lien may be asserted in the jurisdiction where the labor, materials, or equipment were furnished.

15.2 Contract: The agreement between Owner and Contractor identified on the signature page, including all Contract Documents and changes thereto.

15.3 Owner Default: Failure of Owner, which has neither been remedied nor waived, to pay Contractor as required by the Contract, or to perform and complete or otherwise comply with the other terms thereof.

FOR INFORMATION ONLY – *(Name, Address, and Telephone)*

Surety Agency or Broker:

Owner’s Representative *(Engineer or other)*:

SECTION 00700- GENERAL CONDITIONS

ARTICLE 1 - DEFINITIONS AND TERMINOLOGY

1.01 CONTRACT DOCUMENTS:

- A. The Contract Documents establish the rights and obligations of the parties and shall consist of the documents making up the Project Specifications for the City of Mascoutah, Sanitary Sewer Rehabilitation Phase I.
- B. If this Supplemental General Conditions herein are found to be in conflict with the City of Mascoutah's Bidding and Contracting Requirements, the latter shall prevail.
- C. Reports and drawings of subsurface and physical conditions and approved Submittals by Contractor are not Contract Documents.
- D. Only printed or hard copies of items listed in Agreement are Contract Documents. Files in electronic media format of text, data, graphics, and the like that may be furnished by Owner to Contractor are not Contract Documents.

1.02 DEFINITIONS:

- E. Wherever used in these General Conditions or elsewhere in the Contract Documents, the following terms have the meanings indicated below, which are applicable to both the singular and plural thereof:
 - 1. "Addenda" - written or graphic changes or interpretations of the Contract Documents approved by Owner and issued by Engineer prior to the opening of Bids.
 - 2. "Agreement" - the written agreement between Owner and Contractor covering the Work to be performed; other Contract Documents are attached to the Agreement and made a part thereof as provided therein.
 - 3. "Application for Payment" - the form acceptable to Engineer which is to be used by Contractor during the course of the Work in requesting progress and final payments and which is to be accompanied by such supporting documentation as is required by the Contract Documents.
 - 4. "Asbestos" - any material that contains more than 1% asbestos and is friable or is releasing asbestos fibers into the air above current action levels established by the United States Occupational Safety and Health Administration.
 - 5. "Bid" - the formal offer of the Bidder submitted on the prescribed Bid Form together with the required Bid security and all information submitted with the Bid that pertains to performance of the Work.
 - 6. "Bidder" - any person, firm, or corporation submitting a Bid for the Work or their duly authorized representatives.
 - 7. "Change Order" - a written document approved by Owner authorizing an addition, deletion, or revision in the Work, or an adjustment in the Contract Price or the Contract Time issued on or after execution of the Agreement.
 - 8. "Contract Drawings" - drawings and other data designated as Contract Drawings prepared by Engineer for this Contract which show the character and scope of the Work to be performed and are referred to in the Contract Documents.
 - 9. "Contract Price" - the total monies payable to Contractor under the Contract Documents as stated in the Agreement.

10. "Contract Times" - the number of days or the dates stated in the Agreement to: (i) achieve Substantial Completion; and (ii) complete the Work so that it is ready for final payment as evidenced by Engineer's written recommendations of final payment.
11. "Contractor" - the person, firm or corporation with whom Owner has entered into the Agreement.
12. "Date of Contract", "Effective Date of the Agreement" - the date indicated in the Agreement on which it becomes effective, but if no such date is indicated it means the date on which the Agreement is signed and delivered by the last of the two parties to sign and deliver.
13. "Engineer" or "Engineer-Architect" - Architect, engineer, or other licensed professional who is either employed by or has contracted with Owner to serve in a design capacity and whose consultants, members, partners, employees, or agents have prepared and sealed the Drawings and Specifications.
14. "Engineer's Consultant" - an individual or entity having a contract with Engineer to furnish services as Engineer's independent professional associate or consultant with respect to the Project.
15. "Equipment" - a product with operational or non-operational parts, whether motorized or manually operated, that requires service connections, such as wiring or piping.
16. "Field Order" - a written order issued by Engineer which orders minor changes in the Work in accordance with Paragraph 9.05 but which does not involve a change in the Contract Price or the Contract Times.
17. "General Requirements" - Sections of DIVISION 1 of the Specifications. The General Requirements pertain to all sections of the Specifications.
18. "Hazardous Waste" - the term Hazardous Waste shall have the meaning provided in Section 1004 of the Solid Waste Disposal Act (42 USC Section 6903) as amended from time to time.
19. "Law" - law of the place of the Project which shall govern the performance hereunder.
20. "Laws and Regulations," "Laws or Regulations" - laws, rules, regulations, ordinances, codes and/or orders of any and all governmental bodies, agencies, authorities, and courts having jurisdiction.
21. "Lien" - charges, security interests, or encumbrances on Project funds, real property, or personal property.
22. "Materials" - products substantially shaped, cut, worked, mixed, finished, refined, or otherwise fabricated, processed, or installed to form a part of the Work.
23. "Notice of Award" - the written notice by Owner to the apparent successful Bidder stating that upon compliance by the apparent successful Bidder with the conditions precedent enumerated therein, within the time specified, Owner will sign and deliver the Agreement.
24. "Notice to Proceed" - the written notice by Owner to Contractor fixing the date on which the Contract Times will commence to run and on which Contractor shall start to perform Contractor's obligation under the Contract Documents.
25. "Owner" - the City of Mascoutah, Illinois, a constitutionally chartered municipal corporation, with which the Contractor has entered into the Agreement and for whom the Work is to be provided.
26. "Partial Utilization" - placing a portion of the Work in service for the purpose for which it is intended (or a related purpose) before reaching Substantial Completion of all the Work.

27. "PCBs" - Polychlorinated biphenyls.
28. "Petroleum" - petroleum, including crude oil or any fraction thereof which is liquid at standard conditions of temperature and pressure (60o Fahrenheit and 14.7 pounds per square inch absolute), such as oil, petroleum, fuel oil, oil sludge, oil refuse, gasoline, kerosene, and oil mixed with other non-Hazardous Wastes and crude oils.
29. "Project" - the total construction of which the Work to be provided under the Contract Documents may be the whole, or a part as indicated elsewhere in the Contract Documents.
30. "Project Manual" - The bound documentary information prepared for bidding and constructing the Work. A listing of the contents of the Project Manual, which may be bound in one or more volumes, is contained in the table(s) of contents.
31. "Radioactive Material" - source, special nuclear, or byproduct material as defined by the Atomic Energy Act of 1954 (42 USC Section 2011 et seq.) as amended from time to time.
32. "Resident Project Representative" - the authorized representative of Engineer who is assigned to the construction Site or any part thereof.
33. "Reference Drawings" - drawings not specifically prepared for, nor a part of, this Contract, but which contain information pertinent to the Work.
34. "Samples" - physical examples of Equipment, Materials, or workmanship that are representative of some portion of the Work and which establish the standards by which such portion of the Work will be judged.
35. "Shop Drawings" - all drawings, diagrams, illustrations, schedules, and other data or information which are specifically prepared or assembled by or for Contractor and submitted by Contractor to illustrate some portion of the Work.
36. "Site" - lands or areas indicated in the Contract Documents as being furnished by Owner upon which the Work is to be performed, including rights-of-way and easements for access thereto, and such other lands furnished by Owner which are designated for the use of Contractor.
37. "Specifications" - those portions of the Contract Documents consisting of written technical descriptions of the Work, and covering the Equipment, Materials, workmanship, and certain administrative details applicable thereto.
38. "Subcontractor" - an individual, firm, or corporation having a direct contract with Contractor or with any other Subcontractor for the performance of a part of the Work at the Site.
39. "Submittals" - all Shop Drawings, product data, and Samples which are prepared by Contractor, a Subcontractor, manufacturer, or Supplier, and submitted by Contractor to Engineer as a basis for approval by Engineer of the use of Equipment and Materials proposed for incorporation in the Work or needed to describe proper installation, operation and maintenance, or technical properties.
40. "Substantial Completion" - the Work (or a specified part thereof) has progressed to the point where, in the opinion of Engineer as evidenced by his definitive certificate of Substantial Completion, it is sufficiently complete, in accordance with the Contract Documents, so that the Work (or specified part) can be used for the purposes for which it was intended.
41. "Supplementary Conditions" – part of the Contract Documents which, if present, amends and/or supplements these General Conditions.
42. "Supplier" - a manufacturer, fabricator, supplier, distributor, material man, or vendor.
43. "Underground Facilities" - all pipelines, conduits, ducts, cables, wires, manholes, vaults, tanks, tunnels, or other such facilities or attachments, and any

encasements containing such facilities which have been installed underground to furnish any of the following services or materials: electricity, gases, steam, liquid petroleum products, telephone or other communications, cable television, sewage and drainage removal, traffic or other control systems, or water.

44. "Unit Price Work" - Work to be paid on the basis of Unit Prices.
45. "Work" - the entire completed construction or the various separately identifiable parts thereof required to be furnished under the Contract Documents. Work is the result of performing services, the furnishing of Bonds and insurance, furnishing labor, and furnishing and incorporating Materials and Equipment into the construction, all as required by the Contract Documents.
46. "Work Change Directive" - a written directive to Contractor, issued on or after the effective Date of the Agreement and signed by Owner and recommended by Engineer, ordering an addition, deletion, or revision in the Work, or responding to differing or unforeseen physical conditions under which the Work is to be performed as provided in Article 4 or to emergencies under Paragraph 6.13. A Work Change Directive will not change the Contract Price or the Contract Times, but is evidence that the parties expect that the change directed or documented by a Work Change Directive will be incorporated in a subsequently issued Change Order following negotiations by the parties as to its effect, if any, on the Contract Price or Contract Times as provided in Paragraph 10.01B.
47. "Written Amendment" - a written amendment to the Contract Documents, signed by Owner and Contractor on or after the Effective Date of the Agreement, and normally dealing with the non-engineering or non-technical rather than strictly Work-related aspects of the Contract Documents.

1.03 TERMINOLOGY:

- F. Whenever used in these General Conditions or elsewhere in the Contract Documents, the following terminology shall have the intent and meaning specified below:
1. The terms "responsible" or "responsibility" mean that the party to which the term applies shall assume all responsibilities thereto.
 2. The term "approve", when used in response to Submittals, requests, applications, inquiries, reports and claims by Contractor, will be held to limitations of Engineer's responsibilities and duties or specified in these General Conditions. In no case will "approval" by Engineer or Owner be interpreted as a release of Contractor from responsibilities to fulfill requirements of Contract Documents.
 3. When applied to Equipment and Materials, the words "furnish", "install", and "provide" shall mean the following:
 - a. The word "provide" shall mean to furnish, pay for, deliver, assemble, install, adjust, clean and otherwise make Materials and Equipment fit for their intended use.
 - b. The word "furnish" shall mean to secure, pay for, deliver to Site, unload and uncrate Equipment and Materials.
 - c. The word "install" shall mean to assemble, place in position, incorporate in the Work, adjust, clean, and make fit for use.
 - d. The phrase "furnish and install" shall be equivalent to the word "provide."
 4. The word "day" shall constitute a calendar day of twenty-four hours measured from midnight to the next midnight.

ARTICLE 2 - PRELIMINARY MATTERS

2.01 DELIVERY OF BONDS:

- A. When Contractor delivers the executed Agreements to Owner, Contractor shall also deliver to Owner such Bonds as Contractor may be required to furnish in accordance these project specifications.

2.02 COPIES OF DOCUMENTS:

- A. Owner will furnish to Contractor copies of the Contract Documents.

2.03 COMMENCEMENT OF CONTRACT TIMES; NOTICE TO PROCEED:

- A. The Contract Times will commence to run on the day indicated in the Notice to Proceed. A Notice to Proceed may be given at any time within 30 days after the Effective Date of the Agreement. In no event will the Contract Times commence to run later than the 105th day after the day of Bid opening or the 30th day after the Effective Date of the Agreement, whichever date is earlier.

2.04 STARTING THE PROJECT:

- A. Contractor shall start to perform the Work on the date when the Contract Times commence to run, but no Work shall be done at the Site prior to the date on which the Contract Times commence to run.

2.05 BEFORE STARTING CONSTRUCTION:

- A. Before starting construction and undertaking each part of the Work, Contractor shall carefully study and compare the Contract Documents and check and verify pertinent figures shown thereon and all applicable field measurements. Contractor shall promptly report in writing to Engineer any conflict, error or discrepancy which Contractor may discover and shall obtain a written interpretation or clarification from Engineer before proceeding with any Work affected thereby; however, Contractor shall not be liable to Owner or Engineer for failure to report any conflict, error, or discrepancy in the Contract Documents, unless Contractor had actual knowledge thereof or should reasonably have known thereof.
- B. Within ten days after the Effective Date of the Agreement, Contractor shall submit to Engineer for review:
 1. A construction schedule.
 2. A detailed bypass pumping plan
 3. A traffic control plan conforming to all applicable standards
 4. A preliminary schedule of values for all of the Work which will include quantities and prices of items aggregating the Contract Price and will subdivide the Work into component parts in sufficient detail to serve as the basis for progress payments during construction. Such prices will include an appropriate amount of overhead and profit applicable to each item of Work which will be confirmed in writing by Contractor at the time of submission.

- C. Before any Work at the Site is started, Contractor shall deliver to Owner, certificates and other evidence of insurance requested by Owner which Contractor is required to purchase and maintain in accordance with Paragraph 5.02 (and Owner shall deliver to Contractor certificates and other evidence of insurance requested by Contractor which Owner is required to purchase and maintain in accordance with Paragraph 5.02).

2.06 PRECONSTRUCTION CONFERENCE:

- A. Within 14 days after the Effective Date of the Agreement, but before Contractor starts the Work at the Site, a conference attended by Contractor, Engineer, and others as appropriate will be held to discuss the schedules referred to in Paragraph 2.05B, to discuss procedures for handling Submittals, processing Applications for Payment, and to establish a working understanding among the parties as to the Work.

2.07 FINALIZING SCHEDULES:

- A. The construction schedule of major tasks and milestones shall be finalized prior to beginning of Work. The finalized construction progress schedule will be acceptable to Owner if it provides an orderly progression of the Work to completion within the Contract Times, but such acceptance will neither impose on Owner responsibility for the progress or scheduling of the Work nor relieve Contractor from full responsibility therefore. The finalized schedule of Submittal submissions will be acceptable to Owner if it provides a workable arrangement for processing the submissions. The finalized schedule of values will be acceptable to Owner as to form and substance if it provides a reasonable allocation of the Contract Price to components of the Work.

ARTICLE 3 - CONTRACT DOCUMENTS: INTENT, AMENDING, REUSE

3.01 INTENT:

- A. The Contract Documents comprise the entire agreement between Owner and Contractor concerning the Work. The Contract Documents are complementary; what is called for by one is as binding as if called for by all. The Contract Documents will be construed in accordance with the Law of the place of the Project.
- B. It is the intent of the Contract Documents to describe a functionally complete Project (or part thereof) to be constructed in accordance with the Contract Documents. Any Work, Materials, or Equipment that may reasonably be inferred from the Contract Documents as being required to produce the intended result will be supplied whether or not specifically called for, at no additional cost to Owner.
 - 1. When words which have a well-known technical or trade meaning are used to describe Work, Materials, or Equipment, such words shall be interpreted in accordance with that meaning.
 - 2. Reference to standard specifications, manuals, or codes of any technical society, organization, or association, or to the Laws or Regulations of any governmental authority, whether such reference be specific or by implication, shall mean the latest standard specification, manual, code, or Laws or Regulations in effect at the time of opening of Bids except as may be otherwise specifically stated. However, no provision of any referenced standard specification, manual, or code (whether or not specifically incorporated by reference in the Contract Documents) shall be effective to change the duties and responsibilities of Owner,

Contractor, or Engineer, or any of their consultants, agents, or employees from those set forth in the Contract Documents, nor shall it be effective to assign to Engineer, or any of Engineer's consultants, agents or employees, any duty or authority to supervise or direct the furnishing or performance of the Work or any duty or authority to undertake responsibility contrary to the provisions of the Contract Documents.

3. Clarifications and interpretations of the Contract Documents shall be issued by Engineer as provided in Paragraph 9.04.
- C. If, during the performance of the Work, Contractor finds a conflict, error, or discrepancy in the Contract Documents, Contractor shall so report to Engineer and Owner in writing at once and before proceeding with the Work affected thereby shall obtain a written interpretation or clarification from Engineer; however, Contractor shall not be liable to Owner or Engineer for failure to report any conflict, error, or discrepancy in the Contract Documents unless Contractor had actual knowledge thereof or should reasonably have known thereof.
- D. Applicable codes and standards referenced in these Contract Documents establish minimum requirements for Equipment, Materials, and Work and are superseded by more stringent requirements of Contract Documents when and where they occur.
- E. The Specifications are separated into Divisions and Sections for convenience in defining the Work. Contract Drawings are separated according to engineering disciplines and other classifications. This sectionalizing and the arrangement of Contract Drawings shall not control the Contractor in dividing the Work among Subcontractors or Suppliers or delineating the Work to be performed by any specific trade.

3.02 AMENDING AND SUPPLEMENTING CONTRACT DOCUMENTS:

- A. The Contract Documents may be amended to provide for additions, deletions, and revisions in the Work or to modify the terms and conditions thereof in one or more of the following ways:
 1. A formal Written Amendment.
 2. A Change Order (pursuant to Paragraph 10.01D).
- B. As indicated in Paragraphs 11.01B and 12.01A, Contract Price and Contract Times may only be changed by a Change Order or Written Amendment.
- C. In addition, the requirements of the Contract Documents may be supplemented, and minor variations and deviations in the Work may be authorized, in the following way:
 1. A Field Order (pursuant to Paragraph 9.05).
 2. Engineer's written interpretation or clarification (pursuant to Paragraph 9.04).

3.03 OWNERSHIP AND REUSE OF DOCUMENTS:

- A. All Contract Documents and copies thereof furnished by Engineer shall be the property of the Owner.
- B. Neither Contractor nor any Subcontractor or Supplier or other person or organization performing or furnishing any of the Work under a direct or indirect contract with Owner shall have or acquire any title to or ownership rights in any of the Drawings,

Specifications, or other documents (or copies of any thereof) prepared by or bearing the seal of Engineer; and they shall not reuse any of the documents on extensions of the Project or any other project without written consent of Owner and Engineer and specific written verification or adaptation by Engineer.

ARTICLE 4 - AVAILABILITY OF LANDS; PHYSICAL CONDITIONS; REFERENCE POINTS

4.01 AVAILABILITY OF LANDS:

- A. Owner shall furnish, as indicated in the Contract Documents, the lands upon which the Work is to be performed, rights-of-way and easements for access thereto, and such other lands which are designated for the use of Contractor. Easements for permanent structures or permanent changes in existing facilities will be obtained and paid for by Owner, unless otherwise provided in the Contract Documents.
- B. If Contractor believes that any delay in Owner's furnishing these lands, rights-of-way, or easements entitles Contractor to an extension of the Contract Times, Contractor may make a claim therefore as provided in Article 12.
- C. Contractor shall provide for all additional lands and access thereto that may be required for temporary construction facilities or storage of materials and equipment.
- D. Contractor shall confine his operations to the construction limits indicated.
- E. Easements and side letters are attached to these specifications and all conditions set forth are binding upon the Contractor.

4.02 UNFORESEEN SUBSURFACE CONDITIONS:

- A. Contractor shall promptly notify Owner and Engineer in writing of any subsurface or latent physical conditions encountered at the Site which differ materially from those specified or indicated, or which could be reasonably interpreted from examination of the Site and available subsurface information at the time of bidding.
- B. Engineer will promptly investigate those conditions and advise Owner if further surveys or subsurface tests are necessary. Promptly thereafter, Engineer will obtain the necessary additional surveys and tests and furnish copies of results to Contractor, and Owner.
- C. If Engineer finds that the subsurface or latent physical conditions encountered at the Site differ materially from those specified or indicated, or which could have been reasonably interpreted from examination of the Site and available subsurface information at the time of bidding, then a Change Order will be issued by the Owner incorporating the necessary revisions.

4.03 PHYSICAL CONDITIONS - UNDERGROUND FACILITIES:

- A. Shown or Indicated: The information and data shown or indicated in the Contract Documents with respect to existing Underground Facilities at or contiguous to the Site is based on information and data furnished to Owner or Engineer by the owners of such Underground Facilities or by others. Unless it is otherwise expressly provided:

1. Owner and Engineer shall not be responsible for the accuracy or completeness of any such information or data; and,
 2. Contractor shall have full responsibility for reviewing and checking all such information and data, for locating all Underground Facilities shown or indicated in the Contract Documents, for coordination of the Work with the owners of such Underground Facilities during construction, for the safety and protection thereof as provided in Paragraph 6.12 and repairing any damage thereto resulting from the Work, the cost of all of which will be considered as having been included in the Contract Price.
- B. Not Shown or Indicated: If an Underground Facility is uncovered or revealed at or contiguous to the Site which was not shown or indicated in the Contract Documents and which Contractor could not reasonably have been expected to be aware of, Contractor shall, promptly after becoming aware thereof and before performing any Work affected thereby (except in an emergency as permitted by Paragraph 6.13), identify the owner of such Underground Facility and give written notice thereof to that owner and to Owner and Engineer. Engineer will promptly review the Underground Facility to determine the extent to which the Contract Documents should be modified to reflect and document the consequences of the existence of the Underground Facility, and the Contract Documents will be amended or supplemented to the extent necessary. During such time, Contractor shall be responsible for the safety and protection of such Underground Facility as provided in Paragraph 6.12. Contractor shall be allowed an increase in the Contract Price or an extension of the Contract Times, or both, to the extent that they are attributable to the existence of any Underground Facility that was not shown or indicated in the Contract Documents and which Contractor could not reasonably have been expected to be aware of. If the parties are unable to agree as to the amount or length thereof, Contractor may make a claim therefore as provided in Articles 11 and 12.

4.04 REFERENCE POINTS:

- A. Engineer will provide reference points for construction which in Engineer's judgment are necessary to enable Contractor to proceed with the Work. Contractor shall be responsible for laying out the Work (unless otherwise specified in the General Requirements), shall protect and preserve the established reference points, and shall make no changes or relocations without the prior written approval of Engineer. Contractor shall report to Engineer whenever any reference point is lost or destroyed or requires relocation because of necessary changes in grades or locations and shall be responsible for the accurate replacement or relocation of such reference points by professionally qualified personnel. Contractor shall be responsible for any mistakes or loss of time that may result from their loss or disturbance.
- B. Contractor shall make such surveys as are required for establishing pay limits and determining quantities for progress pay estimates. He shall furnish Engineer with one copy each of all field notes of such surveys.

4.05 ASBESTOS, PCBS, PETROLEUM, HAZARDOUS WASTE, OR RADIOACTIVE MATERIAL:

- A. Owner shall be responsible for any Asbestos, PCBs, Petroleum, Hazardous Waste, or Radioactive Material uncovered or revealed at the Site which was not shown or indicated in Drawings or Specifications or identified in the Contract Documents to be within the

scope of the Work and which may present a substantial danger to persons or property exposed thereto in connection with the Work at the Site. Owner shall not be responsible for any such materials brought to the Site by Contractor, Subcontractor, Suppliers, or anyone else for whom Contractor is responsible.

- B. Contractor shall immediately: (i) stop all Work in connection with such hazardous condition and in any area affected thereby (except in an emergency as required by Paragraph 6.13), and (ii) notify Owner and Engineer (and thereafter confirm such notice in writing). Owner shall promptly consult with Engineer concerning the necessity for Owner to retain a qualified expert to evaluate such hazardous condition or take corrective action, if any. Contractor shall not be required to resume Work in connection with such hazardous condition or in any such affected area until after Owner has obtained any required permits related thereto and delivered to Contractor special written notice: (i) specifying that such condition and any affected area is or has been rendered safe for the resumption of Work, or (ii) specifying any special conditions under which such Work may be resumed safely. If Owner and Contractor cannot agree as to entitlement to or the amount or extent of an adjustment, if any, in Contract Price or Contract Times as a result of such Work stoppage or such special conditions under which Work is agreed by Contractor to be resumed, either party may make a claim therefore as provided in Articles 11 and 12.
- C. If after receipt of such special written notice Contractor does not agree to resume such Work based on a reasonable belief it is unsafe, or does not agree to resume such Work under such special conditions, then Owner may order such portion of the Work that is in connection with such hazardous condition or in such affected area to be deleted from the Work. If Owner and Contractor cannot agree as to entitlement to or the amount or extent of an adjustment, if any, in Contract Price or Contract Times as a result of deleting such portion of the Work, then either party may make a claim therefore as provided in Articles 11 and 12. Owner may have such deleted portion of the Work performed by Owner's own forces or others in accordance with Article 7.
- D. To the fullest extent permitted by Laws and Regulations, Owner shall indemnify and hold harmless Contractor, Subcontractors, Engineer, Engineer's Consultants, and the officers, directors, partners, employees, agents, other consultants, and subcontractors of each and any of them from and against all claims, costs, losses, and damages arising out of or resulting from such hazardous condition, provided that: (i) any such claim, cost, loss or damage is attributable to bodily injury, sickness, disease or death, or to injury to or destruction of tangible property (other than the Work itself), including the loss of use resulting there from, and (ii) nothing in this subparagraph 4.05D shall obligate Owner to indemnify any person or entity from and against the consequences of that person's or entity's own negligence.
- E. To the fullest extent permitted by Laws and Regulations, Contractor shall indemnify and hold harmless Owner, Engineer, Engineer's Consultants, and the officers, directors, partners, employees, agents, other consultants, and subcontractors of each and any of them from and against all claims, costs, losses, and damages arising out of or relating to such hazardous condition created by Contractor or by anyone for whom Contractor is responsible. Nothing in this subparagraph 4.05E shall obligate Contractor to indemnify any person or entity from and against the consequences of that person's or entity's own negligence.

- F. The provisions of Paragraphs 4.02 and 4.03 are not intended to apply to Asbestos, PCBs, Petroleum, Hazardous Waste, or Radioactive Material uncovered or revealed at the Site.

ARTICLE 5 - BONDS AND INSURANCE

5.01 PERFORMANCE AND OTHER BONDS:

- A. Contractor shall furnish a performance Bonds as Required in Request for Proposal. These Bonds shall remain in effect at least until one year after the date when final payment is approved by Owner, except as otherwise provided by Law or Regulation or by the Contract Documents. Contractor shall also furnish such other Bonds as are required by the Contract Documents. All Bonds shall be in the forms prescribed by Law or Regulation or by the Contract Documents and be executed by such sureties as are named in the current list of "Companies Holding Certificates of Authority as Acceptable Sureties on Federal Bonds and as Acceptable Reinsuring Companies" as published in Circular 570 (amended) by the Financial Management Service, Surety Bond Branch, U.S. Department of the Treasury. All bonds shall be signed by an Illinois Agent.
- B. The Bonds shall be automatically increased in amount and extended in time without formal and separate amendments to cover full and faithful performance of the Contract in the event of Change Orders, regardless of the amount of time or money involved. It is Contractor's responsibility to notify his surety of any changes affecting the general scope of the Work or change in the Contract Price or Contract Times.
- C. Bonds signed by an agent must be accompanied by a certified copy of the authority to act.
- D. Date of Bonds shall be the same as the Effective Date of the Agreement.
- E. If at any time during the continuance of the Contract, the surety on any Bond becomes unacceptable to Owner for financial reasons, Owner has the right to require additional and sufficient sureties which Contractor shall furnish to the satisfaction of Owner within ten days after notice to do so.
1. If the surety on any Bond furnished by Contractor is declared bankrupt or becomes insolvent or its right to do business is terminated in any state where any part of the Project is located or it ceases to meet the requirements of Paragraph 5.01A, Contractor shall within five days thereafter substitute another Bond and surety, both of which must be acceptable to Owner.

5.02 INSURANCE:

- A. Contractor's Liability Insurance:
1. Contractor and all of his subcontractors shall purchase and maintain such liability and other insurance as is appropriate for the Work being furnished and performed and as will provide protection from claims set forth below which may arise out of or result from Contractor's furnishing and performance of the Work and Contractor's other obligations under the Contract Documents, whether it is to be performed by Contractor, any Subcontractor or Supplier, or by anyone directly or indirectly employed by any of them to perform any of the Work, or by anyone for whose acts any of them may be liable:

- a. Claims under workers' compensation, disability benefits, and other similar employee benefit acts;
 - b. Claims for damages because of bodily injury, occupational sickness or disease, or death of Contractor's employees;
 - c. Claims for damages because of bodily injury, sickness, or disease, or death of any person other than Contractor's employees;
 - d. Claims for damages insured by reasonably available personal injury liability coverage which are sustained: (i) by any person as a result of an offense directly or indirectly related to the employment of such person by Contractor, or (ii) by any other person for any other reason;
 - e. Claims for damages, other than to the Work itself, because of injury to or destruction of tangible property wherever located, including loss of use there from;
 - f. Claims arising out of operation of Laws or Regulations for damages because of bodily injury or death of any person or for damage to property; and
 - g. Claims for damages because of bodily injury or death of any person or property damage arising out of the ownership, maintenance, or use of any motor vehicle.
2. The insurance required by Document 00700, Bidding and Contracting Requirements shall include the specific coverages, and be written for not less than the limits of liability specified or required by Law, whichever is greater.
- B. The policies of insurance so required by paragraph 5.02A to be purchased and maintained shall:
1. with respect to insurance required by Paragraphs 5.02A.1.c through 5.02A.1.g inclusive, include as additional insureds by endorsement (subject to customary exclusion in respect of professional liability) Owner, Engineer, and Engineer's Consultants, and include coverage for the respective officers, directors, partners, employees, agents, and other consultants and subcontractors of each and any of all such additional insureds, and the insurance afforded to these additional insureds shall provide primary coverage for all claims covered thereby;
 2. include at least the specific coverages and be written for not less than the limits of liability specified in Paragraph 5.02A.2 or required by Laws and Regulations, whichever is greater;
 3. with respect to insurance required by paragraphs 5.02A1.c through 5.02A1.g inclusive, include premises/operations, products, completed operations, independent contractors, and personal injury insurance, with employment exclusion deleted;
 4. include in the Commercial General Liability policy, contractual liability insurance covering Contractor's indemnity obligations under Paragraphs 6.06, 6.10, and 6.16, and written for not less than the limits of liability and coverages specified above;
 5. contain a provision or endorsement that the coverage afforded will not be cancelled, materially changed, or renewal refused until at least 30 days' prior written notice by certified mail has been given to Owner and Contractor and to each other additional insured to whom a certificate of insurance has been issued;
 6. provide Broad Form Property Damage coverage and contain no exclusion (commonly referred to as XC&U exclusion) relative to blasting, earthquake, flood, explosion, collapse of buildings, or damage to underground property;

7. remain in effect at least until final payment and at all times thereafter when Contractor may be correcting, removing, or replacing defective Work in accordance with Paragraph 13.07;
8. with respect to completed operations insurance, and any insurance coverage written on a claims-made basis, remain in effect for at least two years after final payment and Contractor shall furnish Owner and each other specified additional insured to whom a certificate of insurance has been issued, evidence satisfactory to Owner and any such additional insured of continuation of such insurance at final payment and one year thereafter;
9. include Independent Contractors Protective Liability coverage; and
10. with respect to the Commercial General Liability policy, the maximum deductible allowed shall be \$5, 000.
11. Owner and Contractor waive all rights against each other and their respective officers, directors, partners, employees, agents, and other consultants and subcontractors of each and any of them for all losses and damages caused by, arising out of, or resulting from any of the perils or causes of loss covered by such policies required by Paragraph 5.02A and any other liability insurance applicable to the Work; and, in addition, waive all such rights against Subcontractors, Engineer, Engineer's Consultants, and all other individuals or entities endorsed as insureds or additional insureds (and the officers, directors, partners, employees, agents, and other consultants and subcontractors of each and any of them) under such policies for losses and damages so caused. As required by Paragraph 6.05D, each subcontract between Contractor and a Subcontractor shall contain similar waiver provisions by the Subcontractor in favor of Owner, Contractor, Engineer, Engineer's Consultants, and all other parties endorsed as insureds or additional insureds. None of the above waivers shall extend to the rights that any of the insured parties may have to proceeds of insurance held by Owner as trustee or otherwise payable under any policy so issued.

C. Owner's Protective Liability Insurance:

1. Contractor shall be responsible for purchasing and maintaining Owner's Protective Liability insurance with Owner and Engineer as named insureds.
2. This insurance shall have the same limits of liability as the Commercial General Liability insurance and shall protect Owner, and Engineer against any and all claims and liabilities for injury to or death of persons, or damage to property caused in whole or in part by, or alleged to have been caused in whole or in part by, negligent acts or omissions of Contractor or Subcontractors or any agent, servant, worker, or employee of Contractor or Subcontractors arising from the operations under the Contract Documents.
3. This insurance may be provided by endorsement to Contractor's Commercial General Liability insurance policy.

D. Property Insurance:

1. Contractor shall purchase and maintain property insurance upon the Work at the Site in the amount of the full insurable value thereof (subject to such deductible amounts as follows) or as required by Laws or Regulations. This insurance shall:
 - a. be on the completed value form and include the interests of Owner, Contractor, Subcontractors, Engineer, and Engineer's Consultants, and the officers, directors, partners, employees, agent, and other consultants and subcontractors of each and any of them, each of whom is deemed to have an insurable interest and shall be listed as an insured;

- b. be written on a Builder's Risk "all-risk" or open peril or special causes of loss policy form that shall at least include insurance for physical loss or damage to the Work, temporary buildings, false work, and Equipment and Materials, and shall insure against at least the following perils or causes of loss: fire, lightning, extended coverage, theft, vandalism and malicious mischief, earthquake, collapse, debris removal, demolition occasioned by enforcement of Laws and Regulations, water damage, terrorism, and such other perils (as flood, earthquake, explosions, collapse, underground hazard) or causes of loss as may be specifically required in the Contract Documents;
 - c. include expenses incurred in the repair or replacement of any insured property (including but not limited to fees and charges of engineers, architects, attorneys, and other professionals);
 - d. cover Equipment and Materials stored at the Site or at another location that was agreed to in writing by Owner prior to being incorporated in the Work, provided that such Equipment and Materials have been included in an Application for Payment recommended by Owner;
 - e. allow for partial utilization of the Work by Owner;
 - f. include testing and startup;
 - g. be maintained in effect until final payment (or the Owner assumes beneficial occupancy and agrees to provide insurance coverage for the facilities so occupied) is made unless otherwise agreed to in writing by Owner, Contractor, and Engineer with 30 days' written notice to each other insured to whom a certificate of insurance has been issued; and have a deductible amount of \$ 10,000.
2. Contractor shall purchase and maintain such boiler and machinery insurance or additional property insurance as required by Laws and Regulations which will include the interests of Owner, Contractor, Subcontractors, Engineer, and Engineer's Consultants in the Work, each of whom is deemed to have an insurable interest and shall be listed as insured or additional insured parties.
 3. All policies of insurance required to be purchased and maintained in accordance with Paragraph 5.02D will contain a provision or endorsement that the coverage afforded will not be cancelled or materially changed or renewal refused until at least 30 days' prior notice by certified mail has been given to Owner and Contractor and to each insured to whom a certificate of insurance has been issued and will contain waiver provisions in accordance with Paragraph 5.02F below.
 4. Copies of the policies shall be furnished for property insurance. Certificates will not be acceptable.

E. Waiver of Rights:

1. Owner and Contractor intend that all policies purchased in accordance with Paragraph 5.02D will protect Owner, Contractor, Subcontractors, Engineer, Engineer's Consultants, and other individuals or entities endorsed as insureds or additional insureds (and the officers, directors, partners, employees, agents, and other consultants and subcontractors of each and any of them) in such policies and will provide primary coverage for all losses and damages caused by the perils or causes of loss covered thereby. All such policies shall contain provisions to the effect that in the event of payment of any loss or damage, the insurers will have no rights of recovery against any of the insureds or additional insureds there under; and if the insurers require separate waiver forms to be signed by Engineer

or Engineer's Consultants, Owner will obtain the same, and if such waiver forms are required of any Subcontractor, Contractor shall obtain the same.

2. Owner and Contractor waive all rights against each other and their respective officers, directors, partners, employees, agents, and other consultants and subcontractors of each and any of them for all losses and damages caused by, arising out of, or resulting from any of the perils or causes of loss covered by such policies required by Paragraph 5.02D and any other property insurance applicable to the Work; and, in addition, waive all such rights against Subcontractors, Engineer, Engineer's Consultants, and all other individuals or entities endorsed as insureds or additional insureds (and the officers, directors, partners, employees, agents, and other consultants and subcontractors of each and any of them) under such policies for losses and damages so caused. As required by Paragraph 6.05D, each subcontract between Contractor and a Subcontractor shall contain similar waiver provisions by the Subcontractor in favor of Owner, Contractor, Engineer, Engineer's Consultants, and all other parties endorsed as insureds or additional insureds. None of the above waivers shall extend to the rights that any of the insured parties may have to proceeds of insurance held by Owner as trustee or otherwise payable under any policy so issued.

F. Receipt and Application of Insurance Proceeds:

1. Any insured loss under the policies of insurance required by Paragraph 5.02D will be adjusted with Owner and made payable to Owner as fiduciary for the insureds, as their interests may appear, subject to the requirements of any applicable mortgage clause and of Paragraph 5.02G.2. Owner shall deposit in a separate account any money so received and shall distribute it in accordance with such agreement as the parties in interest may reach. If no other special agreement is reached, the damaged Work shall be repaired or replaced, the moneys so received applied to account thereof, and the Work and the cost thereof covered by an appropriate Change Order or Written Amendment.
2. Owner as fiduciary shall have power to adjust and settle any loss with the insurers unless one of the parties in interest shall object in writing within 15 days after the occurrence of loss to Owner's exercise of this power. If such objection is made, Owner as fiduciary shall make settlement with the insurers in accordance with such agreement as the parties in interest may reach. If no such agreement among the parties in interest is reached, Owner as fiduciary shall adjust and settle the loss with the insurers and, if required in writing by any party in interest, Owner as fiduciary shall give bond for the proper performance of such duties upon the occurrence of an insured loss.

G. Acceptance of Insurance:

1. If Owner has any objection to the coverage afforded by or other provisions of the insurance required to be purchased and maintained by Contractor in accordance with Paragraph 5.02 on the basis of non-conformance with the Contract Documents, Owner shall so notify Contractor in writing thereof within 10 days of the date of delivery of such certificates and other evidence of insurance to Owner required by Paragraph 2.05C.
2. Owner and Contractor shall each provide to the other such additional information in respect of insurance provided as the other may reasonably request. If either party does not purchase or maintain all of the insurance required of such party by the Contract Documents, such party shall notify the other party in writing of such failure to purchase prior to the start of the Work, or of such failure to maintain

prior to any change in the required coverage. Without prejudice to any other right or remedy, the other party may elect to obtain equivalent insurance to protect such other party's interests at the expense of the party who was required to provide such coverage, and a Change Order shall be issued to adjust the Contract Price accordingly.

- H. Partial Utilization, Acknowledgment of Property Insurer:
 - 1. If Owner finds it necessary to occupy or use a portion or portions of the Work prior to Substantial Completion of all the Work as provided in Paragraph 14.06, no such use or occupancy shall commence before the insurers providing property insurance pursuant to Paragraph 5.02D have acknowledged notice thereof and in writing effected any changes in coverage necessitated thereby. The insurers providing the property insurance shall consent by endorsement on the policy or policies, but the property insurance shall not be cancelled or lapse on account of any such partial use or occupancy.

ARTICLE 6 - CONTRACTOR'S RESPONSIBILITIES

6.01 SUPERVISION AND SUPERINTENDENCE:

- A. Contractor shall supervise and direct the Work competently and efficiently, devoting such attention thereto and applying such skills and expertise as may be necessary to perform the Work in accordance with the Contract Documents. Contractor shall be solely responsible for and have control over construction means, methods, techniques, sequences, and procedures and for coordinating all portions of the Work, but Contractor shall not be responsible for the negligence of others in the design or selection of a specific means, method, technique, sequence, or procedure of construction which is indicated in and required by the Contract Documents. Contractor shall be responsible to see that the finished Work complies accurately with the Contract Documents.
- B. Contractor shall keep on the Work at all times during its progress a competent resident superintendent, who shall not be replaced without written notice to Owner and Engineer except under extraordinary circumstances. The superintendent will be Contractor's representative at the Site and shall have authority to act on behalf of Contractor. All communications given to the superintendent shall be as binding as if given to Contractor.
- C. When manufacturer's field services in connection with the erection, installation, start-up, or testing of Equipment furnished under this Contract, or instruction of Owner's personnel thereon are specified, Contractor shall keep on the Work, during its progress or as specified, competent manufacturer's field representatives and any necessary assistants.

6.02 LABOR, EQUIPMENT, AND MATERIALS:

- A. Contractor shall provide competent, suitably qualified personnel to survey and lay out the Work and perform construction as required by the Contract Documents. Contractor shall at all times maintain good discipline and order at the Site. Except in connection with the safety or protection of persons or the Work or property at the Site or adjacent thereto, and except as otherwise indicated in the Contract Documents, all Work at the Site shall be performed during regular working hours, and Contractor will not permit overtime work or

the performance of Work on Saturday, Sunday, or any legal holiday without Owner's written consent given after prior written notice to Engineer.

- B. Unless otherwise specified in the General Requirements, Contractor shall furnish and assume full responsibility for all Equipment and Materials, labor, transportation, construction equipment and machinery, tools, appliances, fuel, power, light, heat, telephone, water, sanitary facilities, temporary facilities, and all other facilities and incidentals necessary for the furnishing, performance, testing, start-up, and completion of the Work.
- C. All Equipment and Materials shall be of good quality and new, except as otherwise provided in the Contract Documents. If required by Engineer, Contractor shall furnish to Owner satisfactory evidence (including reports of required tests) as to the kind and quality of Equipment and Materials. All Equipment and Materials shall be applied, installed, connected, erected, used, cleaned, and conditioned in accordance with the instructions of the applicable Supplier except as otherwise provided in the Contract Documents; but no provision of any such instructions will be effective to assign to Engineer or any of Engineer's consultants, agents, or employees, any duty or authority to supervise or direct the furnishing or performance of the Work or any duty or authority to undertake responsibility contrary to the provisions of Paragraph 9.10C and 9.10D.
- D. All Equipment and Materials incorporated in the Work shall be designed to meet the applicable safety standards of federal, state, and local Laws and Regulations.
- E. Domestic Product Procurement: Not Applicable.

6.03 ADJUSTING PROGRESS SCHEDULE:

- A. Contractor shall submit to Owner for acceptance (to the extent indicated in Paragraph 2.07) adjustments in the progress schedule to reflect the impact thereon of new developments; these will conform generally to the progress schedule then in effect and additionally will comply with any provisions of the General Requirements applicable thereto.

6.04 SUBSTITUTES OR "OR-EQUAL" ITEMS:

- A. Whenever an item of Equipment or Material is specified or described in the Contract Documents by using the name of a proprietary item or the name of a particular Supplier, the specification or description is intended to establish the type, function, appearance, and quality required. Unless the specification or description contains or is followed by words reading that no like, equivalent, or "or-equal" item or no substitute is permitted, other items of Equipment or Material of other Suppliers may be submitted by Contractor to Owner for review under the circumstances described below.
 - 1. "Or-Equal" Items: If in Engineer's sole discretion an item of Equipment or Material proposed by Contractor is functionally equal to that named and sufficiently similar so that no change in related Work will be required, it may be considered by Engineer as an "or-equal" item, in which case review and approval of the proposed item may, in Engineer's sole discretion, be accomplished without compliance with some or all of the requirements for approval of proposed substitute items. For purposes of this Paragraph 6.04A.1, a proposed item of

Equipment or Material will be considered functionally equal to an item so named if:

- a. In the exercise of reasonable judgment Engineer determines that: (i) it is at least equal in quality, durability, appearance, strength, and design characteristics; (ii) it will reliably perform at least equally well the function imposed by the design concept of the completed Project as a functioning whole, and;
- b. Contractor certifies that: (i) there is no increase in cost to Owner; and (ii) it will conform substantially, even with deviations, to the detailed requirements of the item named in the Contract Documents.

2. Substitute Items:

- a. If in Owner's sole discretion an item of Equipment or Material proposed by Contractor does not qualify as an "or-equal" item under Paragraph 6.04A.1, it will be considered a proposed substitute item.
- b. Contractor shall submit sufficient information as provided below to allow Owner to determine, after consultation with Engineer, that the item of Equipment or Material proposed is essentially equivalent to that named and an acceptable substitute therefore. Requests for review of proposed substitute items of Equipment or Materials will not be accepted by Owner from anyone other than Contractor.
- c. The procedure for review by Owner will be as set forth in Paragraph 6.04A.2.d, as may be supplemented in the General Requirements and as Owner may decide is appropriate under the circumstances.
- d. Contractor shall first make written application to Owner for review of a proposed substitute item of Equipment or Material that Contractor seeks to furnish or use. The application shall certify that the proposed substitute item will perform adequately the functions and achieve the results called for by the general design, be similar in substance to that specified, and be suited to the same use as that specified. The application will state the extent, if any, to which the use of the proposed substitute will prejudice Contractor's achievement of Substantial Completion on time; whether or not use of the proposed substitute item in the Work will require a change in any of the Contract Documents (or in the provisions of any other direct contract with Owner for work on the Project) to adapt the design to the proposed substitute item; and whether or not incorporation or use of the proposed substitute item in connection with the Work is subject to payment of any license fee or royalty. All variations of the proposed substitute item from that specified will be identified in the application, and available engineering, sales, maintenance, repair, and replacement services will be indicated. The application will also contain an itemized estimate of all costs or credits that will result directly or indirectly from use of such substitute item, including costs of redesign and claims of other contractors affected by any resulting change, all of which will be considered by Owner in evaluating the proposed substitute item. Owner may require Contractor to furnish additional data about the proposed substitute item.

- B. If a specific means, method, technique, sequence, or procedure of construction is indicated in or required by the Contract Documents, Contractor may furnish or use a substitute means, method, sequence, technique, or procedure of construction acceptable to Owner and Engineer, if Contractor submits sufficient information to allow Owner to

determine that the substitute proposed is equivalent to that indicated or required by the Contract Documents. The procedure for review by Owner will be similar to that provided in Paragraph 6.04A.2 as applied by Owner and as may be supplemented in the General Requirements.

- C. Owner will be allowed a reasonable time within which to evaluate each proposed substitute or “or-equal” item. Owner will be the sole judge of acceptability, and no substitute or “or-equal” will be ordered, installed, or used until Owner’s review is complete, which will be evidenced by either (i) a Change Order for a substitute, or (ii) an approved Submittal for an “or-equal.” Owner may require Contractor to furnish at Contractor’s expense a special performance guarantee or other surety with respect to any substitute.
- D. Owner will record time required by Engineer, and Engineer’s Consultants in evaluating substitute proposed or submitted by Contractor pursuant to Paragraphs 6.04A.2 and 6.04B and in making changes in the Contract Documents or in the provisions of any other direct contract with Owner for work on the Project occasioned thereby. Whether or not Owner approves a substitute item so proposed or submitted by Contractor, Contractor shall reimburse Owner for the charges of Engineer, and Engineer’s Consultants for evaluating each such proposed substitute.

6.05 CONCERNING SUBCONTRACTORS, SUPPLIERS, AND OTHERS:

- A. Contractor shall not employ any Subcontractor, Supplier, or other person or organization (including those acceptable to Owner and Engineer as indicated in Paragraph 6.05B), whether initially or as a substitute, against whom Owner may have reasonable objection. Contractor shall not be required to employ any Subcontractor, Supplier, or other person or organization to furnish or perform any of the Work against whom Contractor has reasonable objection.
- B. If the Contract Documents require the identity of certain Subcontractors, Suppliers, or other persons or organizations (including those who are to furnish the principal items of Equipment and Materials) to be submitted to Owner within the required time after Bid opening prior to the Effective Date of the Agreement for acceptance by Owner and if Contractor has submitted a list thereof, Owner’s acceptance (either in writing or by failing to make written objection thereto) of any such Subcontractor, Supplier, or other person or organization so identified may be revoked on the basis of reasonable objection after due investigation, in which case Contractor shall submit an acceptable substitute, the Contract Price will be increased by the difference in the cost occasioned by such substitution, and an appropriate Change Order will be issued or Written Amendment signed. No acceptance by Owner or Engineer of any such Subcontractor, Supplier, or other person or organization shall constitute a waiver of any right of Owner to reject defective Work.
- C. Contractor shall be fully responsible to Owner and Engineer for all acts and omissions of the Subcontractors, Suppliers, and other persons and organizations performing or furnishing any of the Work under a direct or indirect contract with Contractor just as Contractor is responsible for Contractor’s own acts and omissions. Nothing in the Contract Documents shall create any contractual relationship between Owner or Engineer and any such Subcontractor, Supplier, or other person or organization, nor shall it create any obligation on the part of Owner or Engineer to pay or to see to the payment of any

moneys due any such Subcontractor, Supplier, or other person or organization except as may otherwise be required by Laws and Regulations.

- D. All Work performed for Contractor by a Subcontractor will be pursuant to an appropriate agreement between Contractor and the Subcontractor which specifically binds the Subcontractor to the applicable terms and conditions of the Contract Documents for the benefit of Owner and Engineer and contains waiver provisions as required by Paragraphs 5.02B and 5.02F. Contractor shall pay each Subcontractor a just share of any insurance moneys received by Contractor on account of losses under policies issued pursuant to Paragraph 5.02D.

6.06 PATENT FEES AND ROYALTIES:

- A. Contractor shall pay all license fees and royalties and assume all costs incident to the use in the performance of the Work or the incorporation in the Work of any invention, design, process, product, or device which is the subject of patent rights or copyrights held by others. If a particular invention, design, process, product, or device is specified in the Contract Documents for use in the performance of the Work and if to the actual knowledge of Owner or Engineer its use is subject to patent rights or copyrights calling for the payment of any license fee or royalty to others, the existence of such rights shall be disclosed by Owner in the Contract Documents.
- B. Contractor shall indemnify and hold harmless Owner and Engineer and anyone directly or indirectly employed by either of them from and against all claims, damages, losses, and expenses (including attorneys' fees and court and arbitration costs) arising out of any infringement of patent rights or copyrights incident to the use in the performance of the Work or resulting from the incorporation in the Work of any invention, design, process, product, or device not specified in the Contract Documents, and shall defend all such claims in connection with any alleged infringement of such rights.

6.07 PERMITS:

- A. Unless otherwise provided in the Contract Documents, Contractor shall obtain and pay for all construction permits and licenses. Owner shall assist Contractor, when necessary, in obtaining such permits and licenses. Contractor shall pay all governmental charges and inspection fees necessary for the prosecution of the Work, which are applicable at the time of opening of Bids. Contractor shall pay all charges of utility owners for connections to the Work, and Owner shall pay all charges of such utility owners for capital costs related thereto such as plant investment fees.

6.08 LAWS AND REGULATIONS:

- A. Contractor shall give all notices and comply with all Laws and Regulations applicable to furnishing and performance of the Work. Except where otherwise expressly required by applicable Laws and Regulations, neither Owner nor Engineer shall be responsible for monitoring Contractor's compliance with any Laws or Regulations.
- B. If Contractor observes that the Specifications or Drawings are at variance with any Laws or Regulations, Contractor shall give Engineer prompt written notice thereof, and any necessary changes will be authorized by one of the methods indicated in Paragraph 3.02. If Contractor performs any Work knowing or having reason to know that it is contrary to

such Laws or Regulations, and without such notice to Engineer, Contractor shall bear all costs arising there from; however, it shall not be Contractor's primary responsibility to make certain that the Specifications and Drawings are in accordance with such Laws and Regulations.

6.09 TAXES:

- A. Contractor shall pay all sales, consumer, use, and other similar taxes required to be paid or withheld by Contractor in accordance with the Laws and Regulations of the place of the Project which are applicable during the performance of the Work.

6.10 USE OF PREMISES:

- A. Contractor shall confine construction equipment, the storage of Equipment and Materials, and the operations of workers to the Project Site and land and areas identified in and permitted by the Contract Documents and other land and areas permitted by Laws and Regulations, rights-of-way, permits, and easements, and shall not unreasonably encumber the premises with construction equipment or other equipment and materials. Contractor shall assume full responsibility for any damage to any such land or area, or to the owner or occupant thereof or of any land or areas contiguous thereto, resulting from the performance of the Work. Should any claim be made against Owner or Engineer by any such owner or occupant because of the performance of the Work, Contractor shall promptly attempt to settle with such other party by agreement or otherwise resolve the claim by arbitration or at Law. Contractor shall, to the fullest extent permitted by Laws and Regulations, indemnify and hold Owner and Engineer harmless from and against all claims, damages, losses, and expenses (including, but not limited to, fees of engineers, architects, attorneys and other professionals, and court and arbitration costs) arising directly, indirectly or consequentially out of any action, legal or equitable, brought by any such other party against Owner or Engineer to the extent based on a claim arising out of Contractor's performance of the Work.
- B. During the progress of the Work, Contractor shall keep the premises free from accumulations of waste materials, rubbish, and other debris resulting from the Work. At the completion of the Work, Contractor shall remove all waste materials, rubbish, and debris from and about the premises as well as all tools, appliances, construction equipment and machinery, and surplus materials, and shall leave the Site clean and ready for occupancy by Owner. Contractor shall restore to original condition all property not designated for alteration by the Contract Documents.
- C. Contractor shall not load nor permit any part of any structure to be loaded in any manner that will endanger the structure, nor shall Contractor subject any part of the Work or adjacent property to stresses or pressures that will endanger it.

6.11 RECORD DOCUMENTS:

- A. Contractor shall maintain in a safe place at the Site one record copy of all Drawings, Specifications, Addenda, Written Amendments, Change Orders, Work Change Directives, Field Test Records, Field Orders, and written interpretations and clarifications (issued pursuant to Paragraph 9.04) in good order and annotated to show all changes made during construction. These record documents together with all approved Samples and a counterpart of all approved Submittals shall be available to Owner and Engineer for

reference. Upon completion of the Work, these record documents and Submittals shall be delivered to Owner.

- B. Receipt and acceptance of record documents will be a prerequisite for final payment on the Contract.

6.12 SAFETY AND PROTECTION:

- A. Contractor shall be responsible for initiating, maintaining, and supervising all safety precautions and programs in connection with the Work. Contractor shall take all necessary precautions for the safety of, and shall provide the necessary protection to prevent damage, injury, or loss to:
 - 1. All employees on the Work and other persons and organizations who may be affected thereby;
 - 2. All the Work and Materials and Equipment to be incorporated therein, whether in storage on or off the Site; and
 - 3. Other property at the Site or adjacent thereto, including trees shrubs, lawns, walks, pavements, roadways, structures, utilities and Underground Facilities not designated for removal, relocation, or replacement in the course of construction.
- B. Contractor shall comply with all applicable Laws and Regulations of any public body having jurisdiction for the safety of persons or property or to protect them from damage, injury, or loss; and shall erect and maintain all necessary safeguards for such safety and protection. Contractor shall notify owners of adjacent property and of Underground Facilities and utility owners when prosecution of the Work may affect them, and shall cooperate with them in the protection, removal, relocation, and replacement of their property. All damage, injury or loss to any property referred to in Paragraph 6.12A.2 or 6.12A.3 caused, directly or indirectly, in whole or in part, by Contractor, any Subcontractor, Supplier, or any other person or organization directly or indirectly employed by any of them to perform or furnish any of the Work or anyone for whose acts any of them may be liable, shall be remedied by Contractor (except damage or loss attributable to the fault of Drawings or Specifications or to the acts or omissions of Owner, Engineer or anyone employed by either of them or anyone for whose acts either of them may be liable, and not attributable, directly or indirectly, in whole or in part, to the fault or negligence of Contractor). Contractor's duties and responsibilities for the safety and protection of the Work shall continue until such time as all the Work is completed and Owner has issued a notice to Contractor in accordance with Paragraph 14.09A that the Work is acceptable (except as otherwise expressly provided in connection with Substantial Completion).
- C. Contractor shall designate a responsible representative at the Site whose duty shall be the prevention of accidents. This person shall be Contractor's superintendent unless otherwise designated in writing by Contractor to Owner.

6.13 EMERGENCIES:

- A. In emergencies affecting the safety or protection of persons or the Work or property at the Site or adjacent thereto, Contractor, without special instruction or authorization from Engineer or Owner, is obligated to act to prevent threatened damage, injury, or loss. Contractor shall give Owner prompt written notice if Contractor believes that any significant changes in the Work or variations from the Contract Documents have been

caused thereby. If Owner determines that a change in the Contract Documents is required because of the action taken in response to an emergency, a Change Order will be issued to document the consequences of the changes or variations.

6.14 SUBMITTALS:

- A. After checking and verifying all field measurements and after complying with applicable procedures specified in the General Requirements, Contractor shall submit to Engineer for review and acceptance, in accordance with the accepted schedule of submissions, copies of Submittals which will bear the required information that Contractor has satisfied Contractor's responsibilities under the Contract Documents with respect to the review of the submission. All submissions will be identified as Engineer may require. The data shown on Submittals will be complete with respect to quantities, dimensions, specified performance and design criteria, materials, and similar data to enable Engineer to review the information as required.
- B. Before submission of each Submittal, Contractor shall have determined and verified all quantities, dimensions, specified performance criteria, installation requirements, materials, catalog numbers, and similar data with respect thereto and reviewed or coordinated each Submittal with other Submittals and with the requirements of the Work and the Contract Documents.
- C. At the time of each submission, Contractor shall give Owner specific written notice of each variation that the Submittal may have from the requirements of the Contract Documents, and in addition, shall cause a specific notation to be made on each Submittal submitted to Owner for review and approval by Engineer of each such variation.
- D. Engineer will review Submittals with reasonable promptness, but Engineer's review and acceptance will be only for conformance with the design concept of the Project and for compliance with the information given in the Contract Documents and shall not extend to means, methods, techniques, sequences, or procedures of construction (except where a specific means, method, technique, sequence, or procedure of construction is indicated in or required by the Contract Documents) or to safety precautions or programs incident thereto. The review and approval of a separate item as such will not indicate approval of the assembly in which the item functions. Contractor shall make corrections required by Engineer, and shall return the required number of corrected copies of Submittals and resubmit as required for review and acceptance. Contractor shall direct specific attention in writing to revisions other than the corrections called for by Engineer on previous Submittals.
- E. Engineer's review and acceptance of Submittals shall not relieve Contractor from responsibility for any variation from the requirements of the Contract Documents. Contractor shall in writing call Owner's and Engineer's attention to each and every variation at the time of submission. Engineer will show acceptance of each such variation by a specific written notation thereof incorporated in or accompanying the Submittal. Acceptance by Engineer shall not relieve Contractor from responsibility for errors or omissions in the Submittals.

- F. Where a Submittal is required by the Specifications, any related Work performed prior to Engineer's review and acceptance of the pertinent submission will be the sole expense and responsibility of Contractor.

6.15 CONTINUING THE WORK:

- A. Contractor shall carry on the Work and adhere to the progress schedule during all disputes or disagreements with Engineer or Owner. No Work shall be delayed or postponed pending resolution of any disputes or disagreements, except as permitted by Paragraph 15.03 or as Contractor and Owner may otherwise agree in writing.

6.16 INDEMNIFICATION:

- A. To the fullest extent permitted by Laws and Regulations, Contractor shall indemnify and hold harmless Owner, Engineer, Engineer's Consultants, and the officers, directors, partners, employees, agents, and other consultants and subcontractors of each and any of them from and against all claims, damages, losses and expenses, direct, indirect, or consequential (including but not limited to fees and charges of engineers, architects, attorneys and other professionals, and court and arbitration costs) arising out of or resulting from the performance of the Work, provided that any such claim, damage, loss, or expense:
1. Is attributable to bodily injury, sickness, disease or death, or to injury to or destruction of tangible property (other than the Work itself) including the loss of use resulting there from, and
 2. Is caused in whole or in part by any negligent act or omission of Contractor, any Subcontractor, supplier, any person, or organization directly or indirectly employed by any of them to perform or furnish any of the Work or anyone for whose acts any of them may be liable, regardless of whether or not it is caused in part by a party indemnified hereunder or arises by or is imposed by Laws and Regulations regardless of the negligence of any such party.
- B. In any and all claims against Owner or Engineer or any of their consultants, agents, or employees by any employee of Contractor, any Subcontractor, supplier, any person, or organization directly or indirectly employed by any of them to perform or furnish any of the Work or anyone for whose acts any of them may be liable, the indemnification obligation under Paragraph 6.16A shall not be limited in any way by any limitation on the amount or type of damages, compensation, or benefits payable by or for Contractor or any such Subcontractor or other person or organization under workers' or workmen's compensation acts, disability benefit acts, or other employee benefit acts.
- C. The obligations of Contractor under Paragraph 6.16A shall not extend to the liability of Engineer, Engineer's Consultants, agents, or employees arising out of:
1. The preparation or approval of maps, drawings, opinions, reports, surveys, Change Orders, designs, or specifications.
 2. The giving of or the failure to give communications by Owner, Engineer, their agents, or employees provided such giving or failure to give is the primary cause of injury or damage.

- D. If necessary for enforcement of any indemnification and hold harmless requirement herein, or if applicable law requires the Contractor to obtain specified limits of insurance to insure any indemnity obligation; then Contractor shall obtain such applicable coverage with minimum limits not less than any specified in Paragraph 5.02B herein, the cost to be recovered and included in the Contract Price, and any indemnity attributable to the negligence of any indemnified party shall be limited to such insurance.

ARTICLE 7 - OTHER WORK

7.01 RELATED WORK AT SITE:

- A. Owner may perform other work related to the Project at the Site by Owner's own forces, have other work performed by utility owners, or let other direct contracts therefore which shall contain General Conditions similar to these. If the fact that such other work is to be performed was not noted in the Contract Documents, written notice thereof will be given to Contractor prior to starting any such other work; and, if Contractor believes that such performance will involve additional expense to Contractor or requires additional time and the parties are unable to agree as to the extent thereof, Contractor may make a claim therefore as provided in Articles 11 and 12.
- B. Contractor shall afford each utility owner and other contractor who is a party to such a direct contract (or Owner, if Owner is performing the additional work with Owner's employees) proper and safe access to the Site and a reasonable opportunity for the introduction and storage of materials and equipment and the execution of such work, and shall properly connect and coordinate the Work with theirs; Contractor shall do all cutting, fitting, and patching of the Work that may be required to make its several parts come together properly and integrate with such other work. Contractor shall not endanger any work of others by cutting, excavating, or otherwise altering their work and will only cut or alter their work with the written consent of Owner and the others whose work will be affected.
- C. If any part of Contractor's Work depends for proper execution or results upon the work of any such other contractor or utility owner or Owner, Contractor shall inspect and promptly report to Owner in writing any delays, defects, or deficiencies in such work that render it unavailable or unsuitable for such proper execution and results. Contractor's failure so to report will constitute an acceptance of the other work as fit and proper for integration with Contractor's Work except for latent or nonapparent defects and deficiencies in the other work.

7.02 COORDINATION:

- A. If Owner contracts with others for the performance of other work on the Project at the Site, the person or organization who will have authority and responsibility for coordination of the activities among the various prime contractors will be identified in the General Requirements, and the specific matters to be covered by such authority and responsibility will be itemized, and the extent of such authority and responsibilities will be provided.

ARTICLE 8 - OWNER'S RESPONSIBILITIES

8.01 CHANGE OF ENGINEER:

- A. In case of termination of the employment of Engineer, Owner shall appoint an engineer against whom Contractor makes no reasonable objection, whose status under the Contract Documents shall be that of the former Engineer. Any dispute in connection with such appointment shall be addressed as discussed in Article 16.

8.02 REQUIRED DATA:

- A. Owner shall furnish the data required of Owner under the Contract Documents promptly and shall make payments to Contractor promptly after they are due as provided in Paragraphs 14.04A and 14.09A.

8.03 LANDS AND EASEMENTS:

- A. Owner's duties in respect of providing lands and easements and providing engineering surveys to establish reference points are set forth in Paragraphs 4.01 and 4.04.

8.04 INSURANCE:

- A. Owner's responsibilities in respect of purchasing and maintaining insurance are set forth in Paragraph 5.02.

8.05 CHANGE ORDERS:

- A. Owner is obligated to execute Change Orders as indicated in Paragraph 10.01.

8.06 INSPECTIONS AND TESTS:

- A. Owner's responsibility in respect of certain inspections, tests and approvals is set forth in Paragraph 13.03B.

8.07 STOPPING THE WORK:

- A. In connection with Owner's right to stop Work or suspend Work, see Paragraphs 13.06, 15.01, and 15.02. Paragraph 15.02A deals with Owner's right to terminate services of Contractor under certain circumstances.

8.08 LIMITATIONS ON OWNER'S RESPONSIBILITIES:

- A. Owner shall not supervise, direct, or have control or authority over, nor be responsible for, Contractor's means, methods, techniques, sequences, or procedures of construction, or the safety precautions and programs incident thereto, or for any failure of Contractor to comply with Laws and Regulations applicable to the performance of the Work. Owner will not be responsible for Contractor's failure to perform the Work in accordance with the Contract Documents.

ARTICLE 9 - ENGINEER'S STATUS DURING CONSTRUCTION

9.01 OWNER'S REPRESENTATIVE:

- A. Engineer will be Owner's Representative during the construction period. The duties and responsibilities and the limitations of authority of Engineer as Owner's Representative during construction are set forth in the Contract Documents and shall not be extended without written consent of Owner and Engineer.

9.02 VISITS TO SITE:

- A. Engineer will make visits to the Site at intervals appropriate to the various stages of construction to observe the progress and quality of the executed Work and to determine, in general, if the Work is proceeding in accordance with the Contract Documents. Engineer will not be required to make exhaustive or continuous on-Site inspections to check the quality or quantity of the Work. Engineer's efforts will be directed toward providing for Owner a greater degree of confidence that the completed Work will conform to the Contract Documents. On the basis of such visits and on-Site observations as an experienced and qualified design professional, Engineer will keep Owner informed of the progress of the Work and will endeavor to guard Owner against defects and deficiencies in the Work.

9.03 PROJECT REPRESENTATION:

- A. Engineer will furnish Resident Project Representative to assist Owner and Engineer in providing more extensive observation of the Work.
 - 1. Communications pertaining to Submittals, written interpretations, and Change Orders shall be directed to Owner and Engineer through the Resident Project Representative.
 - 2. Communications pertaining to day-to-day operations at the Site shall be directed to Resident Project Representative.
 - 3. Resident Project Representative will conduct observations of the Work in progress to assist Owner and Engineer in determining that the Work is proceeding in accordance with the Contract Documents.
 - 4. Resident Project Representative will not have authority to permit any deviation from the Contract Documents, except with concurrence of Owner and Engineer.

9.04 CLARIFICATIONS AND INTERPRETATIONS:

- A. Engineer will issue with reasonable promptness such written clarifications or interpretations of the requirements of the Contract Documents (in the form of drawings or otherwise) as Engineer may determine necessary, which shall be consistent with or reasonably inferable from the overall intent of the Contract Documents. If Contractor believes that a written clarification or interpretation justifies an increase in the Contract Price or an extension of the Contract Times and the parties are unable to agree to the amount or extent thereof, Contractor may make a claim therefore as provided in Article 11 or Article 12.

9.05 AUTHORIZED VARIATIONS IN WORK:

- A. Engineer may authorize minor variations in the Work from the requirements of the Contract Documents which do not involve an adjustment in the Contract Price or the Contract Times and are consistent with the overall intent of the Contract Documents. These may be accomplished by a Field Order and will be binding on Owner, and also on Contractor who shall perform the Work involved promptly.

9.06 REJECTING DEFECTIVE WORK:

- A. Engineer will have authority to disapprove or reject Work which Engineer believes to be defective, and will also have authority to require special inspection or testing of the Work as provided in Paragraph 13.05B, whether or not the Work is fabricated, installed, or completed.
- B. Resident Project Representative will have authority, subject to final decision of Engineer, to disapprove or reject any defective workmanship, Equipment, or Material.

9.07 SUBMITTALS, CHANGE ORDERS, AND PAYMENTS:

- A. In connection with Engineer's responsibility for Submittals, see Paragraph 6.14.
- B. In connection with Engineer's responsibilities as to Change Orders, see Articles 10, 11, and 12.
- C. In connection with Engineer's responsibilities in respect of Applications for Payment, see Article 14.

9.08 DETERMINATIONS FOR UNIT PRICES:

- A. Engineer will determine the actual quantities and classifications of Unit Price Work performed by Contractor. Quantities and classifications will be approved by Owner. Engineer will review with Contractor the Engineer's preliminary determinations on such matters before rendering a written decision thereon to the Owner. Owner will provide approval of an Application for Payment or return Application to Engineer for further review.
- B. Owner's written decisions thereon will be final and binding upon Contractor, unless, within ten days after the date of any such decision, either Owner or Contractor delivers to the other party to the Agreement written notice of intention to appeal such a decision.

9.09 DECISIONS ON DISPUTES:

- A. Engineer will be the initial interpreter of the requirements of the Contract Documents and judge of the acceptability of the Work there under. Claims, disputes, and other matters relating to the acceptability of the Work or the interpretation of the requirements of the Contract Documents pertaining to the performance and furnishing of the Work and claims under Articles 11 and 12 in respect of changes in the Contract Price or Contract Times will be referred to Owner in writing with a request for a formal decision in accordance with this Paragraph, which Owner will render in writing within a reasonable time. Written notice of each such claim, dispute, and other matter will be delivered by the claimant to Owner and the other party to the Agreement promptly (but in no event later than 30 days) after the occurrence of the event giving rise thereto, and written supporting data shall be

delivered to Owner and the other party within 60 days after such occurrence unless Owner allows an additional period of time to ascertain more accurate data in support of the claim. Owner will request written review by Engineer of claims, disputes, and other matters relating to the acceptability of the Work or the interpretation of the requirements of the Contract Documents.

9.10 LIMITATIONS ON ENGINEER'S RESPONSIBILITIES:

- A. Neither Engineer's authority to act under this Article 9 or elsewhere in the Contract Documents nor any decision made by Engineer in good faith either to exercise or not exercise such authority shall give rise to any duty or responsibility of Engineer to Contractor, any Subcontractor, any Supplier, or any other person or organization performing any of the Work, or to any surety for any of them.
- B. Whenever in the Contract Documents the terms "as directed", "as required", "as allowed", "as approved", or terms of like effect or import are used, or the adjectives "reasonable", "suitable", "acceptable", "proper", or "satisfactory" or adjectives of like effect or import are used to describe a requirement, direction, review, or judgment of Engineer as to the Work, it is intended that such requirement, direction, review or judgment will be solely to evaluate the Work for compliance with the Contract Documents (unless there is a specific statement indicating otherwise). The use of any such term or adjective shall not be effective to assign to Engineer any duty or authority to supervise or direct the furnishing or performance of the Work or any duty or authority to undertake responsibility contrary to the provisions of Paragraphs 9.10C or 9.10D.
- C. Engineer will not supervise, direct, control, or have authority over or be responsible for Contractor's means, methods, techniques, sequences, or procedures of construction, or the safety precautions and programs incident thereto, or for any failure of Contractor to comply with Laws and Regulations applicable to the performance of the Work. Engineer will not be responsible for Contractor's failure to perform or furnish the Work in accordance with the Contract Documents.
- D. Engineer will not be responsible for the acts or omissions of Contractor or of any Subcontractor, any Supplier, or of any other person or organization performing or furnishing any of the Work.
- E. The presence or absence of Engineer, or any of its representatives will not act to relieve Contractor of any responsibility or of any guarantee of his performance. Neither will observation by Engineer or any of its representatives in any way be understood to relieve Contractor of any responsibility for proper supervision of the Work at all times.
- F. Review by Engineer of the final Application for Payment and accompanying documentation and all maintenance and operating instructions, schedules, guarantees, Bonds, certificates of inspection, tests and approvals, and other documentation required to be delivered by Paragraph 14.08A will only be to determine generally that their content complies with the requirements of, and in the case of certificates of inspections, tests, and approvals that the results certified indicate compliance with, the Contract Documents.
- G. The limitations upon authority and responsibility set forth in this Paragraph 9.9 shall also apply to Engineer's Consultants, Resident Project Representative, and assistants

ARTICLE 10 - CHANGES IN THE WORK

10.01 GENERAL:

- A. Without invalidating the Agreement and without notice to any surety, Owner may, at any time or from time to time, order additions, deletions, or revisions in the Work; these will be authorized by a Written Amendment, a Change Order, or a Work Change Directive. Upon receipt of any such document authorized, Contractor shall promptly proceed with the Work involved which shall be performed under the applicable conditions of the Contract Documents (except as otherwise specifically provided).
- B. If Owner and Contractor are unable to agree as to the extent, if any, of an increase or decrease in the Contract Price or an extension or a shortening of the Contract Times that should be allowed as a result of a Work Change Directive, a claim may be made therefore as provided in Article 11 or 12.
- C. Contractor shall not be entitled to an increase in the Contract Price or an extension of the Contract Times with respect to any Work performed that is not required by the Contract Documents as amended, modified, and supplemented as provided in Paragraphs 3.02A and 3.02C, except in the case of an emergency as provided in Paragraph 6.13 and except in the case of uncovering Work as provided in Paragraph 13.05B.
- D. Owner and Contractor shall execute appropriate Change Orders (or Written Amendments) covering:
 - 1. Changes in the Work which are ordered by Owner pursuant to Paragraph 10.01A, are required because of acceptance of defective Work under Paragraph 13.09 or correcting defective Work under Paragraph 13.10, or are agreed to by the parties;
 - 2. Changes in the Contract Price or Contract Times which are agreed to by the parties; and
 - 3. Changes in the Contract Price or Contract Times which embody the substance of any written decision rendered by Owner pursuant to Paragraph 9.09A, provided that, in lieu of executing any such Change Order, an appeal may be taken from any such decision in accordance with the provisions of the Contract Documents and applicable Laws and Regulations, but during any such appeal, Contractor shall carry on the Work and adhere to the progress schedule as provided in Paragraph 6.15.
- E. If notice of any change affecting the general scope of the Work or the provisions of the Contract Documents (including, but not limited to, Contract Price or Contract Times) is required by the provisions of any Bond to be given to a surety, the giving of any such notice will be Contractor's responsibility, and the amount of each applicable Bond will be adjusted accordingly.

ARTICLE 11 - CHANGE OF CONTRACT PRICE

11.01 GENERAL:

- A. The Contract Price constitutes the total compensation (subject to authorized adjustments) payable to Contractor for performing the Work. All duties, responsibilities, and obligations assigned to or undertaken by Contractor shall be at his expense without change in the Contract Price.

- B. The Contract Price may only be changed by a Change Order or a Written Amendment. Any claim for an increase or decrease in the Contract Price shall be based on written notice delivered by the party making the claim to the other party and to Owner promptly (but in no event later than thirty (30) days after the occurrence of the event giving rise to the claim and stating the general nature of the claim. Notice of the amount of the claim with supporting data shall be delivered within sixty (60) days after such occurrence (unless Owner allows an additional period of time to ascertain more accurate data in support of the claim) and shall be accompanied by claimant's written statement that the amount claimed covers all known amounts (direct and indirect) to which the claimant is entitled as a result of the occurrence of said event. No claim for an adjustment in the Contract Price will be valid if not submitted in accordance with this Paragraph 11.01B.
- C. The value of any Work covered by a Change Order or of any claim for an increase or decrease in the Contract Price shall be determined in one of the following ways:
1. Where the Work involved is covered by Unit Prices contained in the Contract Documents, by application of Unit Prices to the quantities of the items involved (subject to the provisions of Paragraphs 11.05A through 11.05C, inclusive).
 2. By mutual acceptance of a lump sum (which may include an allowance for overhead and profit not necessarily in accordance with Paragraph 11.03A.2.b).
 3. On the basis of the Cost of the Work (determined as provided in Paragraphs 11.02A and 11.02B) plus a Contractor's Fee for overhead and profit (determined as provided in Paragraphs 11.03A and 11.03B).

11.02 COST OF THE WORK:

- A. The term Cost of the Work means the sum of all costs necessarily incurred and paid by Contractor in the proper performance of the Work. Except as otherwise may be agreed to in writing by Owner, such costs shall be in amounts no higher than those prevailing in the locality of the Project, shall include only the following items and shall not include any of the costs itemized in Paragraph 11.02B.
1. Payroll costs for employees in the direct employ of Contractor in the performance of the Work under schedules of job classifications agreed upon by Owner and Contractor. Payroll costs for employees not employed full time on the Work shall be apportioned on the basis of their time spent on the Work. Payroll costs shall include, but not be limited to, salaries and wages plus the cost of fringe benefits which shall include social security contributions, unemployment, excise and payroll taxes, workers' or workmen's compensation, health and retirement benefits, bonuses, sick leave, vacation, and holiday pay applicable thereto. Such employees shall include superintendents and foremen at the Site. The expenses of performing Work after regular working hours, on Saturday, Sunday, or legal holidays, shall be included in the above to the extent authorized by Owner.
 2. Cost of all Equipment and Materials furnished and incorporated in the Work, including costs of transportation and storage thereof, and Suppliers' field services required in connection therewith. All cash discounts shall accrue to Contractor unless Owner deposits funds with Contractor with which to make payments, in which case the cash discounts shall accrue to Owner. All trade discounts, rebates and refunds, and all returns from sale of surplus materials and equipment shall accrue to Owner, and Contractor shall make provisions so that they may be obtained.

3. Payments made by Contractor to the Subcontractors for Work performed by Subcontractors. If required by Owner, Contractor shall obtain competitive bids from Subcontractors acceptable to Contractor and shall deliver such bids to Owner who will then determine, with the advice of Engineer, which bids will be accepted. If a subcontract provides that the Subcontractor is to be paid on the basis of Cost of the Work Plus a Fee, the Subcontractor's Cost of the Work shall be determined in the same manner as Contractor's Cost of the Work. All subcontracts shall be subject to the other provisions of the Contract Documents insofar as applicable.
4. Costs of special consultants (including but not limited to engineers, architects, testing laboratories, surveyors, attorneys, and accountants) employed for services specifically related to the Work.
5. Supplemental costs including the following:
 - a. The proportion of necessary transportation, travel, and subsistence expenses of Contractor's employees incurred in discharge of duties connected with the Work.
 - b. Costs, including transportation and maintenance, of all materials, supplies, equipment, machinery, appliances, office and temporary facilities at the Site, and hand tools not owned by the workers, which are consumed in the performance of the Work, and cost less market value of such items used but not consumed which remain the property of Contractor.
 - c. Rentals of all construction equipment and machinery and the parts thereof whether rented from Contractor or others in accordance with rental agreements approved by Owner with the advice of Engineer, and the costs of transportation, loading, unloading, installation, dismantling, and removal thereof - all in accordance with terms of said rental agreements. The rental of any such equipment, machinery, or parts shall cease when the use thereof is no longer necessary for the Work.
 - d. Sales, consumer, use, or similar taxes related to the Work, and for which Contractor is liable, imposed by Laws and Regulations.
 - e. Deposits lost for causes other than negligence of Contractor, any Subcontractor, or anyone directly or indirectly employed by any of them or for whose acts any of them may be liable, and royalty payments and fees for permits and licenses.
 - f. Losses and damages not compensated by insurance or otherwise, to the Work or otherwise sustained by Contractor in connection with the performance and furnishing of the Work provided they have resulted from causes other than the negligence of Contractor, any Subcontractor, or anyone directly or indirectly employed by any of them or for whose acts any of them may be liable; shall include settlements made with the written consent and approval of Owner. No such losses, damages, and expenses shall be included in the cost of the Work for the purpose of determining Contractor's fee. If, however, any such loss or damage requires reconstruction and Contractor is placed in charge thereof, Contractor shall be paid for services a fee proportionate to that stated in Paragraph 11.03A.2.
 - g. The cost of utilities, fuel, and sanitary facilities at the Site.
 - h. Minor expenses such as telegrams, long distance telephone calls, telephone service at the Site, expressage, and similar petty cash items in connection with the Work.

- i. Cost of premiums for additional Bonds and insurance required because of changes in the Work and premiums for property insurance coverage within the limits of the deductible amounts established by Owner in accordance with Paragraph 5.02D.4.
- B. The term Cost of the Work shall not include any of the following:
 1. Payroll costs and other compensation of Contractor's officers, executives, principals (of partnerships and sole proprietorships), general managers, engineers, architects, estimators, attorneys, auditors, accountants, purchasing and contracting agents, expeditors, timekeepers, clerks, and other personnel employed by Contractor whether at the Site or in Contractor's principal or a branch office for general administration of the Work and not specifically included in the agreed upon schedule of job classifications referred to in Paragraph 11.02A.1 or specifically covered by Paragraph 11.02A.4, all of which are to be considered administrative costs covered by the Contractor's fee.
 2. Expenses of Contractor's principal and branch offices other than Contractor's office at the Site.
 3. Any part of Contractor's capital expenses, including interest on Contractor's capital employed for the Work, and charges against Contractor for delinquent payments.
 4. Cost of premiums for all Bonds and for all insurance whether or not Contractor is required by the Contract Documents to purchase and maintain the same (except for the cost of premiums covered by subparagraph 11.02A.5.i above).
 5. Costs due to the negligence of Contractor, any Subcontractor, or anyone directly or indirectly employed by any of them or for whose acts any of them may be liable, including but not limited to, the correction of defective Work, disposal of materials or equipment wrongly supplied, and making good any damage to property.
 6. Other overhead or general expense costs of any kind and the costs of any item not specifically and expressly included in Paragraph 11.02A.

11.03 CONTRACTOR'S FEE:

- A. The Contractor's Fee allowed to Contractor for overhead and profit shall be determined as follows:
 1. A mutually acceptable fixed fee; or if none can be agreed upon,
 2. A fee based on the following percentages of the various portions of the Cost of the Work:
 - a. The Contractor's Fee shall not exceed fifteen (15) percent for payroll costs and the cost of materials and equipment as defined in paragraphs 11.02A.1 and 11.02A.2.
 - b. The Contractor's Fee shall not exceed five (5) percent on the work performed by Subcontractors as defined in paragraph 11.02A.3; and if a Subcontract is on the basis of Cost-of-Work plus a Fee, the maximum allowable to the Subcontractor as a fee for overhead and profit shall not exceed fifteen (15) percent:
 - c. No fee shall be payable on costs defined in paragraphs 11.02.A..4, 11.02.A.5, and 11.03 (costs associated with supplemental costs or special consultant);

- d. The amount of credit to be allowed by Contractor to City of Mascoutah for any such change which results in a net decrease in cost, will be the amount of the actual net decrease plus a deduction in Contractor's Fee.
 - e. When both additions and credits are involved in any one change, the adjustment in Contractor's Fee shall be computed on the basis of the net change in accordance with paragraphs 11.03A.2.a. through 11.03.A.2.d.
- B. Whenever the cost of any Work is to be determined pursuant to Paragraph 11.02A or 11.02B, Contractor will submit in form acceptable to Owner an itemized cost breakdown together with supporting data.

11.04 CASH ALLOWANCES:

- A. It is understood that Contractor has included in the Contract Price all allowances so named in the Contract Documents and shall cause the Work so covered to be done by such Subcontractors or Suppliers and for such sums within the limit of the allowances as may be acceptable to Owner. Contractor agrees that:
- 1. The allowances include the cost to Contractor (less any applicable trade discounts) of Equipment and Materials required by the allowances to be delivered at the Site, and all applicable taxes; and
 - 2. Contractor's costs for unloading and handling on the Site, labor, installation costs, overhead, profit, and other expenses contemplated for the allowances have been included in the allowances.
- B. Prior to final payment, an appropriate Change Order will be issued as recommended by Engineer to reflect actual amounts due Contractor on account of Work covered by allowances, and the Contract Price shall be correspondingly adjusted.

11.05 UNIT PRICE WORK:

- A. Where the Contract Documents provide that all or part of the Work is to be Unit Price Work, initially the Contract Price will be deemed to include for all Unit Price Work an amount equal to the sum of the established Unit Prices for each separately identified item of Unit Price Work times the estimated quantity of each item as indicated in the Agreement. The estimated quantities of items of Unit Price Work are not guaranteed and are solely for the purpose of comparison of Bids and determining an initial Contract Price. Determinations of the actual quantities and classifications of Unit Price Work performed by Contractor will be made by Engineer in accordance with Paragraph 9.08.
- B. Each Unit Price will be deemed to include an amount considered by Contractor to be adequate to cover Contractor's overhead and profit for each separately identified item.
- C. Where the quantity of any item of Unit Price Work performed by Contractor exceeds the estimated quantity of such item indicated in the Agreement by twenty-five percent or more and there is no corresponding adjustment with respect to any other item of Work and if Contractor believes that Contractor has incurred additional expense as a result thereof, Contractor may make a claim for an increase in the Contract Price in accordance with Article 11 if the parties are unable to agree as to the amount of any such increase.

11.06 LIMITS OF AUTHORITY:

- A. The contractor shall note and abide by the following City of Mascoutah's and Engineer's limits of authority for changes in the Work which require a change in the Contract Price and Contract Time.

Except in the case of extreme emergency to protect the public safety, public welfare or substantial Work, the following limits of authority to the City of Mascoutah and Engineer shall apply:

Engineer's Representative - No authority

Engineer – No Authority

Owner – Only the City Council may approve a change in the contract amount unless pre-approval is granted to the City Manager.

11.07 RIGHT OF AUDIT:

- A. Owner shall have the right to inspect and audit all of Contractor's books, records, correspondence, instructions, drawings, receipts, payment records, vouchers, and memoranda relating to the Work, and Contractor shall preserve all such records and supporting documentation for a period of three years after date of Final Payment. Contractor hereby grants to Owner the authority to enter Contractor's premises for the purpose of inspection of such records and supporting documentation or, at Contractor's option, Contractor may make such records and supporting documentation available to Owner at a location satisfactory to Owner.
- B. All of the records and supporting documentation shall be open to inspection and subject to audit and reproduction by Owner or its authorized representative for any and all purposes, including but not limited to (i) compliance with the Contract Documents; (ii) proper pricing of Change Orders; and (iii) claims submitted by or against Contractor or any Subcontractor or Supplier in connection with any performance under the Contract Documents.

ARTICLE 12 - CHANGE OF CONTRACT TIMES

12.01 GENERAL:

- A. The Contract Times may only be changed by a Change Order or a Written Amendment. Contractor, in undertaking to complete the Work within the Contract Times, shall take into consideration and make allowances for all of the ordinary delays and hindrances incident to such Work, whether growing out of delays in securing equipment or materials or workmen or otherwise.
- B. Adjustments to the Contract Times will be made for delays in completion of the Work from causes beyond Contractor's control, including the following:
1. Federal embargoes, priority orders, or other restrictions imposed by the United States Government.
 2. Unusual delay in fabrication or shipment of Equipment or Materials required in the Work, whether ordered by Contractor or furnished by Owner or others under separate contract.
 3. Strikes and other labor disputes.
 4. Delays caused by court proceedings.
 5. Change Orders.

6. Neglect, delay, or default of any other contractor employed by Owner.
 7. Unusual construction delays resulting from weather conditions abnormal to the geographical area and to the season of the year such as above normal continuous days of precipitation, above normal amount of precipitation within a 24 hour period, or above normal days of extreme cold or hot temperature conditions affecting installation / application due to manufacturers or specifications limitations. These conditions will not be cause for extensions of time if abnormal weather conditions do not affect the stage of construction. All claims for extension of time due to abnormal weather conditions must be substantiated with evidence from a weather bureau or other authoritative source. Weather conditions normal to the geographical area and to the season of the year shall be taken into consideration in the Bid. Normal conditions shall be defined as the average number of days, amounts, or both over a 5-year period averaged per season.
 8. Conflicts, errors or discrepancies in the Contract Documents reported to Owner or Engineer as provided in these General Conditions.
 9. Any failure or delay by Contractor in supplying equipment, materials, work, or services that are Year 2000 compliant or failure or delay by Contractor's Subcontractors or Suppliers in providing equipment, materials, work, or services as a result of Subcontractors' or Suppliers' lack of Year 2000 compliance in their own operations, systems, or processes used to provide or deliver equipment, material, work, or services shall not be considered to be caused by events beyond Contractor's control. Such Year 2000 compliance problems shall not constitute a basis for delay in completion of the Work, adjustment to the Contract Times, or an excuse for Contract nonperformance.
- C. Owner shall award extensions of the Contract Times on account of such causes of delay, provided that adequate evidence is presented to enable Owner to determine with exactness the extent and duration of delay for each item involved.
- D. No extension to the Contract Times will be granted for delays involving only portions of the Work, or which do not directly affect the time required for completion of the entire Work.
- E. Any claim for an extension to the Contract Times shall be delivered in writing to Owner within ten days of the occurrence of the event giving rise to the claim. All claims for adjustment to the Contract Times will be determined by Owner and Contractor. Any change to the Contract Times resulting from any such claim will be incorporated in a Change Order or a Written Amendment.
- F. All time limits stated in the Contract Documents are of the essence of the Agreement. The provisions of this Article 12 shall not exclude recovery for damages (including but not limited to fees and charges of engineers, architects, attorneys and other professionals, and court and arbitration costs) for delay by either party.

ARTICLE 13 - WARRANTY AND GUARANTEE; TESTS AND INSPECTIONS; CORRECTION, REMOVAL, OR ACCEPTANCE OF DEFECTIVE WORK

13.01 WARRANTY AND GUARANTEE:

- A. Contractor warrants and guarantees to Owner and Engineer that all Work will be in accordance with the Contract Documents and will not be defective. Prompt notice of all

defects shall be given to Contractor. All defective Work, whether or not in place, may be rejected, corrected or accepted as provided in this Article 13.

- B. No provision in the Contract Documents nor any specified guarantee time limit shall be held to limit Contractor's liability for defects to less than the legal limit of liability in accordance with the Law.
- C. All Equipment and Materials furnished by Contractor for the Work shall carry a written guarantee from the manufacturer or Supplier of such items when called for in the Specifications. Written guarantees shall be submitted to Owner with other Submittals.

13.02 ACCESS TO THE WORK:

- A. Engineer and Engineer's representatives, Owner and Owner representatives, testing agencies, and governmental agencies with jurisdictional interests will have access to the Work at reasonable times for their observation, inspecting, and testing. Contractor shall provide proper and safe conditions for such access.

13.03 TESTS AND INSPECTIONS:

- A. Contractor shall give Engineer timely notice of readiness of the Work for all required inspections, tests, or approvals and shall cooperate with inspection and testing personnel.
- B. If Laws or Regulations of any public body having jurisdiction require any Work (or part thereof) to specifically be inspected, tested, or approved, Contractor shall assume full responsibility therefore, pay all costs in connection therewith, and furnish Owner the required certificates of inspection, testing, or approval.
- C. Contractor shall also be responsible for and shall pay all costs in connection with any inspection or testing required in connection with Owner's or Engineer's acceptance of a Supplier of Materials or Equipment proposed to be incorporated in the Work, or of Materials or Equipment submitted for approval prior to Contractor's purchase thereof for incorporation in the Work.
- D. All inspections, tests, or approvals other than those required by Laws or Regulations of any public body having jurisdiction shall be performed by organizations acceptable to Owner and Contractor (or by Engineer if so specified).
- E. If any Work (including the work of others) that is to be inspected, tested, or approved is covered without written concurrence of Engineer, it must, if requested by Engineer, be uncovered for observation. Such uncovering shall be at Contractor's expense unless Contractor has given Engineer timely notice of Contractor's intention to cover the same and Engineer has not acted with reasonable promptness in response to such notice.
- F. Neither observations by Owner or Engineer nor inspections, tests, or approvals by others shall relieve Contractor from Contractor's obligations to perform the Work in accordance with the Contract Documents.

13.04 DEFECTIVE WORK:

- A. The term “defective” is used in these documents to describe Work that is unsatisfactory, faulty, not in conformance with the requirements of the Contract Documents, or not meeting the requirements of any inspection, test, approval, or acceptance required by Law or the Contract Documents.
- B. Any defective Work may be disapproved or rejected by Owner or Engineer at any time before final acceptance even though it may have been overlooked and included in a previous Application for Payment.
- C. Prompt notice will be given by Owner or Engineer to Contractor of defects as they become evident.

13.05 UNCOVERING WORK:

- A. If any Work is covered contrary to the written request of Owner or Engineer, it shall, if requested by Owner or Engineer, be uncovered for Owner’s or Engineer’s observation and replaced at Contractor’s expense.
- B. If Owner or Engineer considers it necessary or advisable that covered Work be observed by Engineer or inspected or tested by others, Contractor, at Owner’s or Engineer’s request, shall uncover, expose, or otherwise make available for observation, inspection, or testing as Owner or Engineer may require, that portion of the Work in question, furnishing all necessary labor, material, and equipment. If it is found that such Work is defective, Contractor shall bear all direct, indirect, and consequential costs of such uncovering, exposure, observation, inspection, and testing and of satisfactory reconstruction, (including but not limited to fees and charges of engineers, architects, attorneys, and other professionals); and Owner shall be entitled to an appropriate decrease in the Contract Price, and, if the parties are unable to agree as to the amount thereof, may make a claim therefore as provided in Article 11. If, however, such Work is not found to be defective, Contractor shall be allowed an increase in the Contract Price or an extension of the Contract Times, or both, directly attributable to such uncovering, exposure, observation, inspection, testing, and reconstruction; and, if the parties are unable to agree as to the amount or extent thereof, Contractor may make a claim therefore as provided in Articles 11 and 12.

13.06 OWNER MAY STOP THE WORK:

- A. If the Work is defective, or Contractor fails to supply sufficient skilled workers or suitable materials or equipment, or fails to furnish or perform the Work in such a way that the completed Work will conform to the Contract Documents, Owner may order Contractor to stop the Work, or any portion thereof, until the cause for such order has been eliminated; however, this right of Owner to stop the Work shall not give rise to any duty on the part of Owner to exercise this right for the benefit of Contractor or any other party.

13.07 CORRECTION OR REMOVAL OF DEFECTIVE WORK:

- A. If required by Owner or Engineer, Contractor shall promptly, as directed, either correct all defective Work, whether or not fabricated, installed or completed, or, if the Work has been rejected by Owner, or Engineer, remove it from the Site and replace it with non-defective Work. Contractor shall bear all direct, indirect, and consequential costs of such

correction or removal (including but not limited to fees and charges of engineers, architects, attorneys, and other professionals) made necessary thereby.

13.08 ONE-YEAR CORRECTION PERIOD:

- A. If within one year after the Date of Substantial Completion or such longer period of time as may be prescribed by Laws or Regulations or by the terms of any applicable special guarantee required by the Contract Documents or by any specific provision of the Contract Documents, any Work is found to be defective, Contractor shall promptly, without cost to Owner and in accordance with Owner's written instructions, either correct such defective Work, or, if it has been rejected by Owner, remove it from the Site and replace it with non-defective Work. If Contractor does not promptly comply with the terms of such instructions, or in an emergency where delay would cause serious risk of loss or damage, Owner may have the defective Work corrected or the rejected Work removed and replaced, and all direct, indirect, and consequential costs of such removal and replacement (including but not limited to fees and charges of engineers, architects, attorneys, and other professionals) will be paid by Contractor. In special circumstances where a particular item of Equipment is placed in continuous service before Substantial Completion of all the Work, the correction period for that item may start to run from an earlier date if so provided in the Specifications or by Written Amendment.

13.09 ACCEPTANCE OF DEFECTIVE WORK:

- A. If, instead of requiring correction or removal and replacement of defective Work, Owner and, prior to Engineer's recommendation of final payment, also Engineer prefers to accept it, Owner may do so. Contractor shall bear all direct and indirect costs attributable to Owner's evaluation of and determination to accept such defective Work (such costs to be approved by Owner as to reasonableness and to include but not be limited to fees and charges of engineers, architects, attorneys, and other professionals). If any such acceptance occurs prior to Owner's recommendation of final payment, a Change Order will be issued incorporating the necessary revisions in the Contract Documents with respect to the Work; and Owner shall be entitled to an appropriate decrease in the Contract Price, and, if the parties are unable to agree as to the amount thereof, Owner may make a claim therefore as provided in Article 11. If the acceptance occurs after such recommendation, an appropriate amount will be paid by Contractor to Owner.

13.10 OWNER MAY CORRECT DEFECTIVE WORK:

- A. If Contractor fails within a reasonable time after written notice of Owner or Engineer to proceed to correct and to correct defective Work or to remove and replace rejected Work as required by Owner or Engineer in accordance with Paragraph 13.07, or if Contractor fails to perform the Work in accordance with the Contract Documents, or if Contractor fails to comply with any other provision of the Contract Documents, Owner may, after seven days' written notice to Contractor, correct and remedy any such deficiency. In exercising the rights and remedies under this Paragraph, Owner shall proceed expeditiously.
- B. To the extent necessary to complete corrective and remedial action, Owner may exclude Contractor from all or part of the Site, take possession of all or part of the Work, and suspend Contractor's services related thereto, take possession of Contractor's tools, appliances, construction equipment, and machinery at the Site and incorporate in the

Work all Equipment and Materials stored at the Site or for which Owner has paid Contractor but which are stored elsewhere.

- C. Contractor shall allow Owner, Owner's representatives, agents, and employees such access to the Site as may be necessary to enable Owner to exercise the rights and remedies under this Paragraph.
- D. All direct, indirect, and consequential costs of Owner in exercising such rights and remedies will be charged against Contractor in an amount approved as to reasonableness by Owner, and a Change Order will be issued incorporating the necessary revisions in the Contract Documents with respect to the Work; and Owner shall be entitled to an appropriate decrease in the Contract Price, and, if the parties are unable to agree as to the amount thereof, Owner may make a claim therefore as provided in Article 11. Such direct, indirect, and consequential costs will include but not be limited to fees and charges of engineers, architects, attorneys and other professionals, all court and arbitration costs, and all costs of repair and replacement of work of others destroyed or damaged by correction, removal, or replacement of Contractor's defective Work.
- E. Contractor shall not be allowed an extension of the Contract Times because of any delay in performance of the Work attributable to the exercise by Owner of Owner's rights and remedies hereunder.

ARTICLE 14 - PAYMENTS TO CONTRACTOR AND COMPLETION

14.01 SCHEDULE OF VALUES:

- A. The schedule of values established will serve as the basis for progress payments and will be incorporated into a form of Application for Payment acceptable to Engineer. Progress payments on account of Unit Price Work will be based on the number of units completed.

14.02 APPLICATION FOR PROGRESS PAYMENT:

- A. Not later than the 15th day of each month, or on the next business day thereafter, (but not more often than once a month), Contractor shall submit to Engineer for review an Application for Payment filled out and signed by Contractor covering the Work completed as of the date of the Application and accompanied by such supporting documentation as is required by the Contract Documents.
- B. Beginning with the second Application for Payment, each Application shall include an affidavit of Contractor stating that all previous progress payments received on account of the Work have been applied on account to discharge Contractor's legitimate obligations associated with prior Applications for Payment.
- C. If payment is requested on the basis of Equipment and Materials not incorporated in the Work but delivered and suitably stored at the Site or at another location agreed to in writing, the Application for Payment shall also be accompanied by a bill of sale, invoice, or other documentation warranting that Owner has received the Equipment and Materials free and clear of all liens, charges, security interests, and encumbrances (which are hereinafter in these General Conditions referred to as "Liens") and evidence that the Equipment and Materials are covered by appropriate property insurance and other

arrangements to protect Owner's interest therein, all of which will be satisfactory to Owner.

- D. The amount of retainage with respect to progress payments will be as stipulated in the City of Mascoutah Bidding and Contracting Requirements, Part 2, section 2.5d.

14.03 CONTRACTOR'S WARRANTY OF TITLE:

- A. Contractor warrants and guarantees that title to all Work, Materials, and Equipment covered by any Application for Payment, whether incorporated in the Project or not, will pass to Owner no later than the time of payment free and clear of all Liens.

14.04 REVIEW OF APPLICATION FOR PROGRESS PAYMENT:

- A. Owner will, within seven days after receipt of each Application For Payment, either indicate in writing a recommendation of payment (subject to the provisions of the last sentence of Paragraph 14.04D), or return the Application to Contractor indicating in writing Owner's reasons for refusing to recommend payment. In the latter case, Contractor may make the necessary corrections and resubmit the Application. After the required internal reviews and processing by the Owner, the Owner will diligently proceed to make payment to the Contractor, in accordance with the approved payment request, within 30 days. All efforts will be made to make payments within the 30 day period, but the Owner cannot guarantee the 30 days maximum time.
- B. Engineer's recommendation of any payment requested in an Application for Payment will constitute a representation by Owner, based on Owner's and Engineer's on-Site observations of the Work in progress as experienced and qualified design professionals and on Owner's and Engineer's review of the Application for Payment and the accompanying data and schedules that the Work has progressed to the point indicated; that, to the best of Owner's and Engineer's knowledge, information, and belief, the quality of the Work is in accordance with the Contract Documents (subject to an evaluation of the Work as a functioning whole prior to or upon Substantial Completion, to the results of any subsequent tests called for in the Contract Documents, to a final determination of quantities and classifications for Unit Price Work under Paragraph 9.08, and to any other qualifications stated in the recommendation); and that Contractor is entitled to payment of the amount recommended. However, by recommending any such payment, Owner will not thereby be deemed to have represented that exhaustive or continuous on-Site inspections have been made to check the quality or the quantity of the Work beyond the responsibilities specifically assigned to Owner in the Contract Documents, or that there may not be other matters or issues between the parties that might entitle Contractor to be paid additionally by Owner or Owner to withhold payment to Contractor.
- C. Engineer's recommendation of final payment will constitute an additional representation by Engineer that the conditions precedent to Contractor's being entitled to final payment as set forth in Paragraph 14.09 have been fulfilled.
- D. Engineer may refuse to recommend the whole or any part of any payment if, in Engineer's opinion, it would be incorrect to make such representations to Engineer. Engineer may also refuse to recommend any such payment, or, because of subsequently discovered evidence or the results of subsequent inspections or tests, nullify any such payment

previously recommended, to such extent as may be necessary in Owner's opinion to protect Owner from loss because:

1. The Work is defective, or completed Work has been damaged requiring correction or replacement.
 2. Written claims have been made against Owner or Liens have been filed in connection with the Work.
 3. The Contract Price has been reduced by Written Amendment or Change Order
 4. Owner has been required to correct defective Work or complete Work in accordance with Paragraph 13.10,
 5. Of Owner's actual knowledge of the occurrence of any of the events enumerated in Paragraph 15.02B.
 6. Of Contractor's unsatisfactory prosecution of the Work in accordance with the Contract Documents.
 7. Contractor's failure to make payment to Subcontractors, or for labor, Materials, or Equipment, or
 8. Owner shall not certify payments requesting more than eighty (80) percent of the Contract amount until such time as all operation, maintenance, repair, and replacement manuals, and product data has been furnished by the Contractor to the Owner.
- E. Owner may refuse to make payment of the full amount because claims have been made against Owner on account of Contractor's performance of furnishing of the Work, or Liens have been filed in connection with the Work, or there are other items entitling Owner to a set-off against the amount recommended, but Owner must give Contractor immediate written notice stating the reasons for such action.
- F. When all grounds for withholding payment are removed, payment will be made in the amounts withheld because of them.

14.05 SUBSTANTIAL COMPLETION:

- A. When Contractor considers the entire Work ready for its intended use, Contractor shall notify Owner in writing that the entire Work is substantially complete (except for items specifically listed by Contractor as incomplete) and request that Owner issue a certificate of Substantial Completion.
- B. Within a reasonable time thereafter, Owner, Contractor, and Engineer shall make an inspection of the Work to determine the status of completion. If Owner or Engineer does not consider the Work substantially complete, Owner or Engineer will notify Contractor in writing giving his reasons therefore. If Owner and Engineer consider the Work substantially complete, Owner will prepare a tentative certificate of Substantial Completion which will fix the Date of Substantial Completion. There shall be attached to the certificate a tentative list of items to be completed or corrected before final payment.
- C. At the time of delivery of the tentative certificate of Substantial Completion, Owner will deliver to Contractor a written recommendation as to division of responsibilities pending final payment between Owner and Contractor with respect to security, operation, safety, maintenance, heat, utilities, insurance, and warranties.

- D. Owner shall have the right to exclude Contractor from the Work after the Date of Substantial Completion, but Owner shall allow Contractor reasonable access to complete or correct items on the tentative list.

14.06 PARTIAL UTILIZATION:

- A. Use by Owner of any finished part of the Work, which has specifically been identified in the Contract Documents, or which Owner, Engineer, and Contractor agree constitutes a separately functioning and useable part of the Work that can be used by Owner without significant interference with Contractor's performance of the remainder of the Work, may be accomplished prior to Substantial Completion of all the Work subject to the following:
 - 1. Owner at any time may request Contractor in writing to permit Owner to use any such part of the Work which Owner believes to be ready for its intended use and substantially complete. If Contractor agrees, Contractor will certify to Owner and Engineer that said part of the Work is substantially complete and request Owner to issue a certificate of Substantial Completion for that part of the Work. Contractor at any time may notify Owner and Engineer in writing that Contractor considers any such part of the Work ready for its intended use and substantially complete and request Owner to issue a certificate of Substantial Completion for that part of the Work. Within a reasonable time after either such request, Owner, Contractor, and Engineer shall make an inspection of that part of the Work to determine its status of completion. If Engineer does not consider that part of the Work to be substantially complete, Engineer will notify Owner and Contractor in writing giving the reasons therefore. If Engineer considers that part of the Work to be substantially complete, the provisions of Paragraph 14.05 will apply with respect to certification of Substantial Completion of that part of the Work and the division of responsibility in respect thereof and access thereto.
 - 2. Owner may at any time request Contractor in writing to permit Owner to take over operation of any such part of the Work although it is not substantially complete. Within a reasonable time thereafter, Owner, Contractor and Engineer shall make an inspection of that part of the Work to determine its status of completion and will prepare a list of the items remaining to be completed or corrected thereon before final payment. If Contractor does not object in writing to Owner that such part of the Work is not ready for separate operation by Owner, Owner will finalize the list of items to be completed or corrected and will deliver such list to Contractor together with a written recommendation as to the division of responsibilities pending final payment between Owner and Contractor with respect to security, operation, safety, maintenance, utilities, insurance, warranties, and guarantees for that part of the Work, which will become binding upon Owner and Contractor at the time when Owner takes over such operation. During such operation and prior to Substantial Completion of such part of the Work, Owner shall allow Contractor reasonable access to complete or correct items on said list and to complete other related Work.
 - 3. No occupancy or separate operation of part of the Work will be accomplished prior to compliance with the requirements of Paragraph 5.02I in respect of property insurance.

14.07 FINAL INSPECTION:

- A. Upon written notice from Contractor that the Work or an agreed portion thereof is complete, Engineer will make a final inspection with Owner and Contractor and Owner

will notify Contractor in writing of all particulars in which this inspection reveals that the Work is incomplete or defective. Contractor shall immediately take such measures as are necessary to remedy such deficiencies.

14.08 FINAL APPLICATION FOR PAYMENT:

- A. After Contractor has completed all such corrections to the satisfaction of Owner and Engineer and delivered all maintenance and operating instructions, schedules, guarantees, Bonds, certificates of inspection, marked-up record documents, and other documents - all as required by the Contract Documents, and after Owner has indicated that the Work is acceptable (subject to the provisions of Paragraph 14.11), Contractor may make application for final payment following the procedure for progress payments.
- B. The final Application for Payment shall be accompanied by all documentation called for in the Contract Documents, together with complete and legally effective releases or waivers (satisfactory to Owner) of all Liens arising out of or filed in connection with the Work. In lieu thereof and as approved by Owner, Contractor may furnish receipts or releases in full; an affidavit of Contractor that the releases and receipts include all labor, services, Material, and Equipment for which a Lien could be filed, and that all payrolls, Equipment and Material bills, and other indebtedness connected with the Work for which Owner or Owner's property might in any way be responsible, have been paid or otherwise satisfied; and consent of the surety, if any, to final payment. If any Subcontractor or Supplier fails to furnish a release or receipt in full, Contractor may furnish a Bond or other collateral satisfactory to Owner to indemnify Owner against any Lien.

14.09 FINAL PAYMENT AND ACCEPTANCE:

- A. If, on the basis of Owner's and Engineer's observation of the Work during construction and final inspection, and Owner's review of the final Application for Payment and accompanying documentation -- all as required by the Contract Documents, Owner is satisfied that the Work has been completed and Contractor's other obligations under the Contract Documents have been fulfilled, Owner will give written notice to Contractor that the Work is acceptable (subject to the provisions of Paragraph 14.11). Otherwise, Owner will return the Application to Contractor, indicating in writing the reasons for refusing to recommend final payment, in which case Contractor shall make the necessary corrections and resubmit the Application. Thirty days after presentation to Owner of the Application and accompanying documentation, in appropriate form and substance, and with Owner's recommendation and notice of acceptability, the amount recommended by Owner will become due and will be paid to Contractor.
- B. If, through no fault of Contractor, final completion of the Work is significantly delayed and if Owner and Engineer so confirms, Owner shall, upon receipt of Contractor's final Application for Payment, and without terminating the Agreement, make payment of the balance due for that portion of the Work fully completed and accepted. The written consent of the surety to the payment of the balance due for that portion of the Work fully completed and accepted shall be submitted by Contractor to Owner with the Application for such payment. Such payment shall be made under the terms and conditions governing final payment, except that it shall not constitute a waiver of claims.
- C. The Final Pay Estimate will include all sums remaining to be paid.

14.10 CONTRACTOR'S CONTINUING OBLIGATION:

- A. Contractor's obligation to perform and complete the Work in accordance with the Contract Documents shall be absolute. Neither recommendation of any progress or final payment by Owner, nor the issuance of a certificate of Substantial Completion, nor any payment by Owner to Contractor under the Contract Documents, nor any use or occupancy of the Work or any part thereof by Owner, nor any act of acceptance by Owner nor any failure to do so, nor any review and approval of a Submittal, nor the issuance of a notice of acceptability by Owner pursuant to Paragraph 14.09, nor any correction of defective Work by Owner will constitute an acceptance of Work not in accordance with the Contract Documents or a release of Contractor's obligation to perform the Work in accordance with the Contract Documents (except as provided in Paragraph 14.11).

14.11 WAIVER OF CLAIMS:

- A. The making and acceptance of final payment will constitute:
1. A waiver of all claims by Owner against Contractor, except claims arising from unsettled Liens, from defective work appearing after final inspection pursuant to Paragraph 14.07, or from failure to comply with the Contract Documents or the terms of any special guarantees specified therein; however, it will not constitute a waiver by Owner of any rights in respect of Contractor's continuing obligations under the Contract Documents; and
 2. A waiver of all claims by Contractor against Owner other than those previously made in writing and still unsettled.

ARTICLE 15 - SUSPENSION OF WORK AND TERMINATION

15.01 OWNER MAY SUSPEND WORK:

- A. Owner may, at any time and without cause, suspend the Work or any portion thereof for a period of not more than 90 days by notice in writing to Contractor and Engineer which will fix the date on which Work will be resumed. Contractor shall resume the Work on the date so fixed. Contractor shall be allowed an increase in the Contract Price or an extension of the Contract Times, or both, directly attributable to any suspension if Contractor makes an approved claim therefore as provided in Articles 11 and 12.

15.02 OWNER MAY TERMINATE:

- A. Upon the occurrence of any one or more of the following events:
1. If Contractor commences a voluntary case under any chapter of the Bankruptcy Code (Title 11, United States Code), as now or hereafter in effect, or if Contractor takes any equivalent or similar action by filing a petition or otherwise under any other federal or state Law in effect at such time relating to the bankruptcy or insolvency;
 2. If a petition is filed against Contractor under any chapter of the bankruptcy Code as now or hereafter in effect at the time of filing, or if a petition is filed seeking any such equivalent or similar relief against Contractor under any other federal or state Law in effect at the time relating to bankruptcy or insolvency;
 3. If Contractor makes a general assignment for the benefit of creditors;

4. If a trustee, receiver, custodian, or agent of Contractor is appointed under applicable Law or under contract, whose appointment or authority to take charge of property of Contractor is for the purpose of enforcing a Lien against such property or for the purpose of general administration of such property for the benefit of Contractor's creditors;
 5. If Contractor admits in writing an inability to pay its debts generally as they become due;
 6. If Contractor persistently fails to perform the Work in accordance with the Contract Documents (including, but not limited to, failure to supply sufficient skilled workers or suitable Equipment or Materials or failure to adhere to the progress schedule established under Paragraph 2.07 as revised from time to time);
 7. If Contractor disregards Laws or Regulations of any public body having jurisdiction;
 8. If Contractor disregards the authority of Owner or Engineer; or
 9. If Contractor otherwise violates in any substantial way any provisions of the Contract Documents;
- B. Owner may, after giving Contractor (and the surety, if there be one) ten days' written notice and to the extent permitted by Laws and Regulations, terminate the services of Contractor, exclude Contractor from the Site and take possession of the Work and of all Contractor's tools, appliances, construction equipment, and machinery at the Site and use the same to the full extent they could be used by Contractor (without liability to Contractor for trespass or conversion), incorporate in the Work all Equipment and Materials stored at the Site or for which Owner has paid Contractor but which are stored elsewhere, and finish the Work as Owner may deem expedient. In such case, Contractor shall not be entitled to receive any further payment until the Work is finished. If the unpaid balance of the Contract Price exceeds the direct and indirect costs of completing the Work (including but not limited to fees and charges of engineers, architects, attorneys and other professionals, and court costs), such excess will be paid to Contractor. If such costs exceed such unpaid balance, Contractor shall pay the difference to Owner. Such costs incurred by Owner will be incorporated in a Change Order, but when exercising any rights or remedies under this Paragraph, Owner shall not be required to obtain the lowest price for the Work performed.
- C. Where Contractor's services have been so terminated by Owner, the termination will not affect any rights or remedies of Owner against Contractor then existing or which may thereafter accrue. Any retention or payment of moneys due to Contractor by Owner will not release Contractor from liability.
- D. Upon ten days' written notice to Contractor and Engineer, Owner may, without cause and without prejudice to any other right or remedy, elect to abandon the Work and terminate the Agreement. In such case, Contractor shall be paid for all Work executed and any expense sustained plus reasonable termination expenses, which will include, but not be limited to, direct and indirect costs (including, but not limited to, fees and charges of engineers, architects, attorneys and other professionals, and court costs).

15.03 CONTRACTOR MAY STOP WORK OR TERMINATE:

- A. If, through no act or fault of Contractor, the Work is suspended for a period of more than 90 days by Owner or under an order of court or other public authority, or Owner fails to

act on any Application for Payment within 30 days after it is submitted, or Owner fails for 30 days to pay Contractor any sum finally determined to be due, then Contractor may, upon ten days' written notice to Owner and Engineer, terminate the Agreement and recover from Owner payment for all Work executed and any expense sustained plus reasonable termination expenses. In addition and in lieu of terminating the Agreement, if Owner has failed to act on an Application for Payment or Owner has failed to make any payment as aforesaid, Contractor may upon ten days' written notice to Owner stop the Work until payment of all amounts then due. The provisions of this Paragraph shall not relieve Contractor of the obligations under Paragraph 6.15 to carry on the Work in accordance with the progress schedule and without delay during disputes and disagreements with Owner.

ARTICLE 16 - RESOLUTION OF DISPUTES

16.01 RESOLUTION OF CLAIMS AND DISPUTES:

- A. Owner's claims against Contractor will be reviewed by Contractor who shall take one or more of the following actions within ten (10) days after receipt of the Claim:
 - 1. Request additional supporting data from Owner;
 - 2. Submit a schedule to the Owner indicating a reasonable time within which Contractor expects to take action;
 - 3. Deny the claim in whole or in part, stating reasons for denial;
 - 4. Recommend approval of the claim; or
 - 5. Suggest a compromise.
- B. If a claim has been resolved, the Owner will prepare or obtain appropriate documentation.
- C. If a claim has been denied or if no action has been taken in the manner provided in Paragraphs 16.01A or 16.01B, then the claimant, within ten (10) days thereafter, may notify the Owner, the other party, and Contractor's surety that Owner and Contractor have been unable to resolve the claim. In that event, the Owner, pursuant to Paragraph 16.01E shall review the claim and make a decision on the claim.
- D. If a claim is presented to the Owner, then the Owner shall review the claim and make a decision within fourteen (14) days.
- E. Disputes that cannot be settled through negotiation or the procedures in Paragraphs 16.01A through 16.01E above, shall be settled as mutually agreed or in a court of competent jurisdiction within the State of Illinois.
- F. Arbitration shall not be used in the settlement of disputes.

ARTICLE 17 - MISCELLANEOUS

17.01 GIVING NOTICE:

- A. Whenever any provision of the Contract Documents requires the giving of written notice, it will be deemed to have been validly given if delivered in person to the individual or to a member of the firm or to an officer of the corporation for whom it is intended, or if

delivered at or sent by registered or certified mail, postage prepaid, to the last business address known to the giver of the notice.

17.02 COMPUTATION OF TIME:

- A. When any period of time is referred to in the Contract Documents by days, it will be computed to exclude the first and include the last day of such period. If the last day of any such period falls on a Saturday or Sunday or on a day made a legal holiday by the Law of the applicable jurisdiction, such day will be omitted from the computation.
- B. A calendar day of 24 hours measured from midnight to the next midnight shall constitute a day.

17.03 CLAIMS, CUMULATIVE REMEDIES:

- A. Should Owner or Contractor suffer injury or damage to person or property because of any error, omission, or act of the other party or of any of the other party's employees or agents or others for whose acts the other party is legally liable, claim will be made in writing to the other party within a reasonable time of the first observance of such injury or damage. The provisions of this Paragraph shall not be construed as a substitute for or a waiver of the provisions of any applicable statute of limitations or repose.
- B. The duties and obligations imposed by these General Conditions and the rights and remedies available hereunder to the parties hereto, and, in particular but without limitation, the warranties, guarantees and obligations imposed upon Contractor by Paragraphs 6.16A, 13.01, 13.08, 13.10, 14.03, and 15.02A and all of the rights and remedies available to Owner and Engineer there under, are in addition to, and are not to be construed in any way as a limitation of, any rights and remedies available to any or all of them which are otherwise imposed or available by Laws or Regulations, by special warranty or guarantee, or by other provisions of the Contract Documents, and the provisions of this Paragraph will be as effective as if repeated specifically in the Contract Documents in connection with each particular duty, obligation, right, and remedy to which they apply. All representations, warranties, and guarantees made in the Contract Documents will survive final payment and termination or completion of the Agreement.

END OF SECTION 00700

TABLE OF CONTENTS
FOR
SECTION 02000 SPECIFICATIONS
DIVISION 1
GENERAL REQUIREMENTS

Section	Subject
D1-1	SUMMARY OF WORK
D1-3	SUBMITTALS
D1-4	MATERIAL AND PERFORMANCE TESTING
D1-5	CONTROL OF CONSTRUCTION SITE(S)
D1-6	MEASUREMENT AND PAYMENT
D1-7	MANHOLE TESTING
D1-8	SANITARY SEWER REPAIR TESTING
D1-10	TRENCH SAFETY SYSTEM
D1-11	ENVIRONMENTAL SPECIFICATIONS

D1-1 SUMMARY OF WORK

A. General

1. The Special Conditions and Provisions Documents, and the rules, regulations, requirements, instructions, drawings or details referred to by manufacturer's name, number or identification included therein as specifying, referring or implying product control, performance, quality, or other shall be binding upon the Contractor. The specifications and drawings shall be considered cooperative; therefore, work or material called for by one and not shown or mentioned in the other shall be accomplished or furnished in a faithful manner as though required by all.

The order of precedence in case of conflicts or discrepancies between various parts of the Contract Documents subject to the ruling of the Engineer shall generally, but not necessarily, follow the guidelines listed below:

1. Contract Documents

The following special conditions shall be applicable to this project and shall be given over any conflicts with the Contract Documents under the provisions stated above.

2. Work Covered By Contract

The work to be performed is generally described in the Notice to Bidders and indicated in the Contract Documents. The sewer rehabilitation work to be completed under this contract shall be as indicated on the drawing and as described in the Contract Documents.

3. Contractor's Duties

- a. Except as specifically noted, provide and pay for:
 - 1) Labor, materials, and equipment.
 - 2) Tools, construction equipment, and machinery.
 - 3) Samples, shipping costs, and tests.
 - 4) Necessary utilities, such as water supply, electrical power, telephones, roads, fences, and sanitary facilities, including maintenance thereof.
 - 5) Other facilities and services necessary for proper execution and completion of work.
- b. Perform all the work described in these specifications except where specifically indicated to be done by others.
- c. Pay legally required patent fees, sales, consumer, and use taxes.
- d. Secure and pay for legally required permits, licenses, and government fees.

- e. Give required notices.
 - f. Employ workmen and foremen with sufficient knowledge, skill, and experience to perform the work assigned to them.
 - g. Comply with codes, laws, ordinances, rules, regulations, orders, and other legal requirements of public authorities bearing on the conduct of the work.
 - h. Submit written notice to Owner's Representative of observed variance of Contract Documents from legal requirements. Any necessary changes will be adjusted as provided in the Contract for changes in the work.
 - i. Enforce discipline and good order among Contractor and subcontractor employees. Any person employed by Contractor or subcontractors who does not perform his work in a skillful manner, is incompetent, or acts in a disorderly or intemperate manner shall, at the written request of Owner, be removed from the project immediately and shall not be employed in any portion of the work without the approval of Owner.
 - j. Provide at all times facilities for access and inspection of the work by representatives of Owner and by official governmental agencies designated by Owner as having the right to inspect the work.
 - k. Cooperate with other contractors who may be performing work of Owner, and with Owner's employees working in the vicinity of the work done under the Contract.
 - l. Submit shop drawings on all materials and equipment to be installed on the project.
4. Contractor's Use of Premises
- a. Confine operations at site to areas permitted by law, ordinances, permits, and the Contract Documents.
 - b. Do not load or permit any part of a structure to be subjected to any force that will endanger its safety.
 - c. Comply with and enforce Owner's instructions regarding signs, advertisements, fires, and smoke.
 - d. Assume responsibility for protection and safekeeping of products stored on premises.
 - e. Do not discharge smoke, dust, or other contaminants into the atmosphere, or fluids or materials into any waterway as will violate regulations of any legally constituted authority.
 - f. Move stored products which interfere with the operations of Owner or other Contractors.
 - g. Obtain and pay for additional storage or work areas needed for operations.

h. No alcohol shall be consumed on the site.

i. Existing Manhole Steps

The steps of the existing manholes cannot be guaranteed for safety, therefore, Contractor shall provide all necessary equipment to assure safe access and a safe working environment inside the manhole.

5. Existing Facilities

a. The existing facilities will be in continuous operation during the construction period.

b. Plan and conduct construction operations to avoid disturbing existing structures, piping, equipment, and services in any manner which will interrupt or impair operations, except as approved by Owner's Representative.

c. Submit for approval a construction sequence, and written explanations of the temporary facilities and appurtenances intended to be used in maintaining the uninterrupted operation of the existing sanitary sewer system and any other affected utilities.

6. Sequence of Construction

a. The Contractor shall contact property owners 48 hours in advance describing the work to be performed on private property prior to any construction or rehabilitation work on that property.

b. Sanitary sewer line point repairs and sanitary relief sewers or replacement sewers shall be scheduled together for construction when in the same immediate vicinity.

c. Excavation work shall be performed in an orderly manner so that all excavation work is completed in an area before moving to another area unless authorization is given by the Engineer or Owner.

d. Prior to final surface restoration, the Contractor shall insure that all testing has been completed and reviewed by the Engineer.

e. The Contractor shall submit to the Engineer each night the next days proposed activities.

f. The Contractor shall submit a weekly schedule on each Thursday for the next week's construction activities.

g. A revised monthly progress schedule shall be submitted with each payment request.

h. The Contractor shall maintain flow in the existing sanitary sewer lines until all connections have been made to the proposed system. All connections to existing manholes shall be considered a non-pay item.

- i. The City shall not reimburse the Contractor for any water used to perform the work as required in the contract.
- j. The Contractor shall provide all sanitary sewer by-passes as required to perform the work as specified in the plan and specifications as a non-pay item.
- k. The Contractor shall preserve all trees, shrubs, sprinkler systems, fences, and other property owner improvements located within the limits of the construction. The removal and/or replacement of the said property owner improvements by the Contractor shall be considered as a non-pay item unless noted otherwise.
- l. All local residents who will be denied access to their driveways shall be notified by the Contractor two (2) working days prior to the closure of their access.
- m. All driveways which are open cut shall have at least a temporary riding surface at the end of each day and will be considered a non-pay item.
- o. All cast iron frames and lids from manhole structures which are required to be removed shall be disposed by the Contractor at no additional cost to the Contract.

10. Abbreviations

The following abbreviations as used in the Contract Documents have the listed meanings:

- Aampere
- AASHTOAmerican Association of State Highway and Transportation
..... Officials
- ACIAmerican Concrete Institute
- ANSIAmerican National Standards Institute
- AREAAmerican Railroad Engineers Association
- ASTMAmerican Society for Testing and Materials
- AWWAAmerican Water Works Association

- Bilbasic impulse insulation level
- BODbiochemical oxygen demand
- btuBritish Thermal Unit

- C.....degrees Celsius
- cccubic centimeter
- cfcubic foot
- cfmcubic feet per minute
- Co.....Company
- concconcrete
- CorpCorporation
- CRSIConcrete Reinforcing Steel Institute
- cucubic
- cycubic yard

- EAEach

- Fdegrees Fahrenheit

SSPC Steel Structural Painting Counsel
sy square yard

UL Underwriters Laboratory
U.S United States

V volt
VF Vertical Foot

END OF SECTION D1-1

D1-3 SUBMITTALS

A. Progress Schedule

1. Prepare a detailed progress schedule in graphic form showing proposed dates of starting and completing each major division of the work, monthly completion percentages, and anticipated monthly payment requests.
2. The schedule shall be consistent with the time and order of work requirements of the Specifications, and shall be the basis of Contractor's operations.
3. A condensed critical path method schedule is preferred but another practicable form of presentation will be acceptable.
4. Submit three copies to Engineer within 10 days after the effective date of Award.
5. At the end of every pay request period, submit a revised schedule showing the current status of the work as compared to the projected status. The current application for a progress payment will not be processed until the revised schedule is delivered to Engineer.

B. General

1. Shop Drawings, Project Data, and Samples

a. General

Submit to Owner's Representative shop drawings, project data, and samples required by the Specifications.

b. Shop Drawings

- 1) Shop drawings are original drawings prepared by the Contractor, subcontractors, suppliers, or distributors which illustrate some portion of the work and show fabrication, layout, setting, or erection details of equipment, materials, and components.
- 2) Unless otherwise instructed, submit to Owner's Representative for review and approval three prints of each plan or two prints and one reproducible sepia or reproducible on vellum. Owner Representative will return with review comments one print or one reproducible.
- 3) Shop drawings shall be 8-1/2 by 11 inches, 8-1/2 by 14 inches or standard size plans, or as directed by Owner Representative, and shall be clearly identified as to location of the equipment, material, and apparatus in the work.

- 4) Fold drawings to an approximate size of 8-1/2 by 11 inches in such a manner that the title block will be located in the lower right hand corner of the exposed surface. Roll, do not fold, reproducible copies of drawings.
- 5) Furnish Owner Representative, as requested, without extra charge, the number of complete sets of prints of shop drawings as Owner Representative shall request for office files and for use in the field.

c. Project Data

- 1) Project data are manufacturers' standard schematic drawings, catalog sheets, brochures, diagrams, schedules, performance charts, illustrations, parts lists and other standard descriptive data.
- 2) Modify drawings to delete information not applicable and to add information applicable to the project.
- 3) Mark copies of printed material to identify pertinent materials, products, or models.
- 4) Show dimensions and clearances required, performance characteristics and capacities, and wiring diagrams and controls.
- 5) Submittal procedures shall be the same as for shop drawings.

d. Samples

- 1) Samples are examples to illustrate materials, equipment, or workmanship, and to establish standards by which completed work is judged.
- 2) Samples submitted shall be of sufficient size and quantity to illustrate functional characteristics of product or material and full range of colors available.
- 3) Field samples and mock-ups when required by the specifications shall be erected at the project site where directed.

e. Contractor Responsibilities

- 1) Review and approve shop drawings, project data, and samples before submitting them.
- 2) Verify field measurements, field construction criteria, catalog numbers, and similar data.
- 3) Coordinate each submittal with the requirements of the Contract Documents.
- 4) Submit shop drawings for major equipment items in one package to permit checking complete installation details.

- 5) In a clear space above the title block, or on the back, hand stamp the following, and enter the required information:

Name of Owner - City of Mascoutah

Project Name - City of Mascoutah
Manhole & Pipe Rehabilitation

Date _____

Identification _____

Contract Drawing No. __

Specification Section _____

This document has been checked for accuracy of content and for compliance with the Contract Documents and is hereby approved. The information contained herein has been coordinated with all involved Contractors.

Contractor _____

Signed _____

- 6) Contractor's responsibility for errors, omissions, and deviations from requirements of the Contract Documents in submittals is not relieved by Owner's Representative's review.
- 7) Notify Owner's Representative, in writing at time of submittal, of deviations in submittals from requirements of the Contract Documents.
- 8) Do not install materials or equipment which require submittals until the submittals are returned with Owner's Representative's stamp and initials or signature indicating review.
- 9) Revise returned shop drawings as required and resubmit until final approval is obtained. Indicate on the drawings any changes which have been made other than those requested by Owner's Representative.
- 10) Submit new project data and samples when the initial submittal is returned disapproved.
- 11) No claim will be allowed for damages or extension of time because of delays in the work resulting from rejection of material or from revision and resubmittal of shop drawings, project data, or samples.

f. Owners Representative's Duties

- 1) Owner's Representative will review submittals for compliance with the Contract Documents and with the design concept of the project.

- 2) Review of a separate item does not constitute acceptance of an assembly in which the item functions.
- 3) Owner's Representative will affix a stamp to the returned copy of each submittal. The stamp will be marked to indicate "Furnish as Submitted", "Furnish as Corrected", "Rejected", or "No Review Required". The stamp will be initialed or signed certifying the submittal review.

2. Video Tape Recordings of Surface Conditions

- a. Video tape recordings of surface conditions shall be provided for all relief sewers, replacement sewers, and sewer point repairs.
- b. The following location information shall be provided on color audio-video tape recording.
 - 1) Audio: Each recording shall begin with a verbal description of the current date, project name and municipality and be followed by the general location, i.e., name of the street, viewing side and direction of progress.
 - 2) Video: Transparent information must appear on the viewing screen. This information will consist of the date and time of recording. The data information will contain the month, day and year.
 - 3) Digital: To preclude the possibility of tampering or editing in any manner, all video recordings must, by electronic means, display continuously and simultaneously generated transparent digital information to include the date and time of recording. The date information will contain the month, day and year.
- c. The taped coverage shall include all surface features located within the zone of influence of construction supported by appropriate audio description. Audio description shall be made simultaneously with video coverage. Such coverage shall include, but not be limited to, all existing driveways, sidewalks, fences, curbs, ditches, roadways, landscaping, trees, culverts, headwalls, retaining walls, or buildings located within such zone of influence. Particular and detailed attention shall be given to any defects noted, such as cracks, disturbed areas, damaged items, or as may be required by the Engineer. It is the intent of this coverage to accurately and clearly document pre-existing conditions and especially any items that could result in construction claims. The excavation areas shall be physically marked with high visibility fluorescent paint prior to videotaping. The markings shall include the job number and stationing.
- d. The zone of influence shall be defined as an area within 30 feet of the proposed work, and an additional 20 feet of supplemental coverage shall be provided in residential areas.

- e. The Contractor shall be able to televise and tape areas with paved roads, along co-owned easements through parks, lawns, and open fields. If videotaping on private property, the Contractor shall give the Owner sufficient prior notice of such entry so that property owners may be advised of and their permission obtained for the work.
- f. To produce the proper detail and perspective, adequate lighting will be required to fill in the shadow area caused by trees, utility poles, road signs and other such objects in residential areas or as directed by the Engineer.
- g. Houses and buildings shall be identified visually by house number, when visible, in such a manner that structures of the proposed system, i.e., manholes on a sewer system and hydrants on a water system, can be located by reference.
- h. The rate of speed in the general direction of travel of the conveyance used during taping shall not exceed 48 feet per minute in residential areas, nor exceed 100 feet per minute in non-residential areas. Panning rates and zoom-in, zoom-out rates shall be controlled sufficiently such that during playback will produce clarity of the object viewed. The playback picture shall be in focus and be of extreme clarity at all times.
- i. All taping shall be done during times of good visibility. No taping shall be done during periods of visible precipitation, or when more than 10% of the ground area is covered with snow, unless otherwise authorized by the Engineer.
- j. The Owner shall have the authority to designate what areas may be omitted or added for audio-video coverage.
- k. All media shall be properly identified by tape number, location and project name and municipality in a manner acceptable to the Owner.
- l. A record of the contents of each tape shall be supplied by a run sheet identifying each segment in the tape by location, i.e., roll number, street or road viewing, tape counter number, viewing side, point starting from, traveling direction and ending destination point.
- m. Conventional wheeled vehicles cannot be used.
- n. Audio-video shall be produced in an .mpeg format. An effort should be made to utilize the same recorder that would be required for review of the sewer line televising.
- q. Any portion of the video tape recording not conforming to specifications shall be rejected.
- r. Any taped coverage not acceptable to the Owner shall be re-filmed at no additional charge. The Contractor shall reschedule unacceptable coverage five (5) days after being notified.
- s. All taping shall be performed by Contractor and reviewed prior to construction.
- t. One original and two copies are to be provided. Original to Owner, one copy to Engineer, and one copy to Contractor.

3. Final Inspections
 - a. Notify Owner in writing when project, or designated portion of project, is substantially complete.
 - b. Owner's Representative will make an inspection of the substantially completed work, and prepare and submit to Contractor a list of items to be completed or corrected.
 - c. Take immediate steps to remedy the listed deficiencies, and notify Owner in writing that the project is complete and ready for final inspection.
 - d. Owner's Representative will make a final inspection and, if he considers the work is complete, he will notify Owner that the work is ready for final acceptance.
4. Closeout Submittals
 - a. Special guarantees and bonds.
 - b. Certificates of inspection required by laws and ordinances for mechanical and electrical work, and any other legally required inspections.
 - c. Contractor's Waiver of Liens.
 - d. Separate Waivers of Lien for subcontractors, suppliers, and others with lien rights against property of Owner.
 - e. Final payment estimate.
5. Work Schedule
 - a. Prepare a detailed weekly work schedule and submit the schedule to the Owner's Representative on the Thursday before the schedule is to take effect.
 - b. Contractor shall update the weekly work schedule on a daily basis so to advise the Owner's Representative where and on what the Contractor will be working.
 - c. Work schedule shall include, but not be limited to, a listing of job numbers and manholes that will be worked on a daily basis and a brief description of the type of work to take place.

C. Measurement and Payment

Payment will be at the contract lump sum price for Video Documentation which price shall include all labor, equipment, and materials necessary to complete the work. No other Contract Prices are established for Submittals.

END OF SECTION D1-3

D1-4 MATERIAL AND PERFORMANCE TESTING

A. General

1. Scope
 - a. Perform the inspections and tests required by the Specifications.
 - b. Provide product certification as required by the Specifications.
 - c. Neither observations by Owner's Representative, nor inspections, tests, or approvals by other than Contractor, shall relieve Contractor from his obligation to perform the work in accordance with the requirements of the Contract Documents.
2. Testing Laboratory Services
 - a. Employ the services of an independent testing laboratory to perform specified services.
 - b. Obtain approval of Owner before employing laboratory.
 - c. Laboratory shall meet "Recommended Requirements for Independent Laboratory Qualification" published by the American Council of Independent Laboratories.
 - d. Laboratory shall meet basic requirements of ASTM E329, "Standards of Recommended Practice for Inspection and Testing Agencies for Concrete and Steel as Used in Construction".
3. Laboratory Duties
 - a. Perform specified tests and services.
 - b. Comply with specified standards, ASTM, other recognized authorities, and as specified.
 - c. Ascertain compliance with requirements of Contract Documents and so note in writing on all reports.
 - d. Promptly notify Owner's Representative and Contractor of irregularities or deficiencies of work observed during performance of services.

- e. Promptly submit three copies of reports of inspections and tests to Owner's Representative.
 - f. Include in the reports, the date, project title, number, name and signature of inspector, date of inspection or sample, record of temperature and weather, date of test, identification of product and Specification Section, location in project, type of test, and observations regarding compliance with requirements.
4. Contractor's Responsibilities
- a. Cooperate with laboratory personnel.
 - b. Provide laboratory with samples of materials to be tested in required quantities.
 - c. Furnish to the Owner's Representative three copies of test results.
 - d. Provide facilities for storage and curing of test samples.
 - e. Notify Owner's Representative sufficiently in advance of time and place of tests to be made at point of manufacture, assembly, or fabrication to permit Owner's Representative to witness tests if he so desires.

B. Measurement and Payment

No Contract Prices are established for Material and Performance Testing.

END OF SECTION D1-4

D1-5 CONTROL OF CONSTRUCTION SITE(S)

A. General

1. Removal of Debris

Keep the work sites free from accumulating waste materials and rubbish caused by his work or employees. All materials and equipment required on the site shall be kept in such a manner so as to cause a minimum of inconvenience and nuisance to other Contractors and the general public. The site shall be kept broom clean.

2. Traffic Control

a. Contractor shall, at all times, conduct the work in such a manner as to insure least obstruction to vehicular and pedestrian traffic while paying particular attention to avoid inconvenience in hospital and school zones. Notify Owner's Representative at least three work days in advance of starting any construction work which might inconvenience or endanger traffic. A minimum of one lane shall be open to traffic at all times.

b. Submit a traffic control plan to Owner, Owner's Representative, and appropriate highway official three days prior to closing any road. Contractor shall inform police, fire, public works, and bus service companies on the day of closure.

c. When any section or portion of road is closed to traffic, provide, erect, and maintain barricades, red flags, detour signs, and torches or lights at each end of the closed section, at all intersecting roads, and at all locations shown on the plans, in accordance with any City of Mascoutah Standard Specification.

d. Contractor shall provide a sequencing arrow panel when performing construction on heavily traveled roads and streets. The sign panel shall consist of a minimum of 22 amber lamps. The lamps shall be divided into two groups of three arrowheads each with arrowheads of each group aligned or behind the other laterally and the arrowheads of separate groups being opposed.

e. Replace any traffic sign or post which has been damaged or removed because of the contractor's operations.

f. Contractor shall provide access to private property. Driveways, sidewalks, and alleys shall not be blocked for periods greater than two hours.

3. Fencing shall be placed around open excavation or trenches at the end of a day in a manner acceptable to the Owner's Representative and the Owner. Fencing and placement of same shall meet the approval of the Owner's Representative.

4. Equipment Operation

a. Where the Contractor's equipment is operated on any portion of a traveled surface or structures used by traffic on or adjacent to the section under construction, the Contractor shall clean the traveled surface of all dirt and debris at the end of each

day's operations. The cost of this work shall be included in the unit price bid and no additional compensation will be allowed.

- b. Protect traveled surfaces and structures on or adjacent to the work, in a manner satisfactory to the Owner's Representative, from damage by lugs or cleats or equipment. Walking of tracked-rolled equipment directly on paved streets, driveways, curbs, or sidewalks shall not be allowed.
- c. Equipment used in the performance of the work shall comply with legal loading limits established by the statutes of State or local regulations when moved over or operated on any traveled surface or structure unless permission in writing has been issued by the Owner's Representative. Before using any equipment which may exceed the legal loading, the Contractor shall secure a permit, allowing ample time for an analysis of stresses to determine whether or not the proposed loading is within safe limits. The Owner will not be responsible for any delay in construction operations or for any costs incurred by the Contractor as a result of compliance with the above requirements.

5. Utilities

- a. The Contractor shall notify public and private utility companies which may have overhead or underground facilities in the area at least 48 hours before construction begins. The Contractor shall make necessary arrangements for having these companies to locate, protect, brace or move their facilities as may be necessary for construction of the improvements. Costs incurred due to the moving, bracing, or protection of utilities or in satisfying the requirements of the utility companies shall be incidental to the cost of the proposed improvement.
- b. The Contractor shall proceed with caution with excavation operations so that the exact location of underground utilities and structures, both known and unknown, may be determined. The Contractor shall take all reasonable precautions against damage to the utility or structure. However, in the event of a break in an existing utility, he shall immediately notify a responsible official from the organization operating the utility. The Contractor shall lend all possible assistance in restoring service, and shall assume all costs connected with the repair of any damaged utility.

- c. It is understood and agreed that the Contractor has considered in his bid all of the permanent and temporary utility appurtenances in their present or relocated positions and that no additional compensation will be allowed for any delays, inconvenience, or damage sustained by him due to any interference from the said utility appurtenances or the operation of moving them either by the utility companies or by him; or on account of any special construction methods required in prosecuting his work due to the existence of said appurtenances either in their present or relocated positions.

6. Accident Reporting

a. Notification

Accidents occurring on the job which damage public or private property, or result in injury to workers or other persons, shall be promptly reported to the Police Department.

b. Utilities

Accidents involving utilities shall also be reported to them. This applies to all accidents, including, but not limited to, traffic accidents, broken pipe lines, power and telephone facilities and damage to adjacent properties.

B. Measurement and Payment

No Contract Prices are established for Control of Construction Site.

END OF SECTION D1-5

D1-6 MEASUREMENT AND PAYMENT

A. General

The Contract price shall cover all Work required by the Contract Documents. All costs in connection with the proper and successful completion of the Work, including furnishing all materials, equipment, supplies, and appurtenances; providing all equipment and tools; and performing all necessary labor and supervision to fully complete the Work, shall be included in the unit and lump sum prices bid. All Work not specifically set forth as a pay item in the Agreement shall be considered a subsidiary obligation of Contractor and all costs in connection therewith shall be included in the Contract prices.

1. Estimated Quantities

Quantities stipulated in the Bid Form or Contract Documents are approximate and are to be used only (a) as a basis for estimating the probable cost of the Work and (b) for the purpose of comparing the bids submitted for the Work. The actual amounts of work done and materials furnished under unit price items may differ from the estimated quantities. The basis of payment for work and materials will be the actual amount of work done and materials furnished. Contractor agrees that he will make no claim for damages, anticipated profits, or otherwise on account of any difference between the amounts of work actually performed and materials actually furnished and the estimated amounts therefore.

2. Measurements and Payments

Payments will be made in accordance with the General Conditions for actual quantities constructed or installed in accordance with the Contract Documents, be they more or less than the listed quantities; said quantities being measured as hereinafter specified.

3. Items Not Listed In Contract

There shall be no measurement or separate payment for any items not listed in the Contract and all costs pertaining thereto shall be included in the contract unit prices for other items listed.

END OF SECTION D1-6

D1-7 MANHOLE TESTING

A. General

1. Scope

This section describes manhole testing to effectively confirm the watertight integrity of new manholes and existing manholes following infiltration related repairs and inflow related repairs.

2. Description

- a. Infiltration may be observed in manhole defects at manhole walls, pipe seals or bench/trough areas. Infiltration related repairs are intended to eliminate leakage of groundwater into manholes.
- b. Inflow may be observed in manhole defects at manhole frames, covers, frame seals, grade adjustments, grade adjustment seals, corbels, or walls. Inflow related repairs are intended to eliminate sources of surface water entry that become active during rainfall events.

3. Testing, Observations and Guarantee Period

- a. The testing required shall be performed by the Contractor at locations designated by the Engineer and documented to the satisfaction of the Engineer.
- b. The Contractor shall test rehabilitation work completed by the Contractor and by the Owner. Testing shall not be performed on a specific manhole until all work as shown on the Manhole Rehabilitation Schedule has been completed for that specific manhole.
- c. Any rehabilitated manholes or new manholes that are observed to be leaking by the Engineer shall be subject to additional repairs. The Contractor shall only be responsible for all additional repairs of those work items completed by the Contractor.

B. Materials

Not specified.

C. Execution

1. Infiltration Testing

- a. All new manholes shall be vacuum tested by the Contractor in the presence of the Engineer for sources of infiltration. Testing will be made during high groundwater conditions, wherever possible.

- b. Manholes shall be tested after installation with all connections (existing and/or proposed) in place. Drop-connections and gas sealing connections shall be installed prior to testing. The lines entering the manhole shall be temporarily plugged with the plugs braced to prevent them from being drawn into the manhole. The plugs shall be installed in the lines beyond drop-connections, gas sealing connections, etc. The test head shall be placed inside the frame at the top of the manhole (so that the manhole frame seal is tested) and inflated in accordance with the manufacturer's recommendations. A vacuum of 10 inches of mercury shall be drawn, and the vacuum pump will be turned off. With the valve closed, the level of vacuum shall be read after the required test time. If the drop in the level is less than 1-inch of mercury (final vacuum greater than 9 inches of mercury), the manhole will have passed the vacuum test. The Contractor shall spray a soap solution on the manhole wall and pipe seals to help determine leakage sites. After a successful test, the temporary plugs will be removed. The required test time is determined from Table I.

Table I			
MINIMUM TIME REQUIRED FOR A VACUUM DROP OF 1" H _g (10"H _g - 9"H _g) (MIN:SEC)			
HEIGHT OF M.H.(DEPTH IN FT.)	48" M.H.	60" M.H.	72" M.H.
0 - 20'	:40	:50	1:00
22'	:44	:55	1:06
24'	:48	1:00	1:12
26'	:52	1:05	1:18
28'	:56	1:10	1:24
30'	1:00	1:15	1:30
ADDITIONAL 2'DEPTHS- ADDFOR EACH 2'	:04	:05	:06

- c. Manhole vacuum levels observed to drop greater than 1-inch of mercury (Final vacuum less than 9 inches of mercury) will have failed the test. The Contractor shall make the necessary repairs at no additional compensation. The manhole shall then be retested as described above until a successful test is made.

2. Inflow Testing

- a. All new manholes shall be dyed water tested in the presence of the Engineer. The dye test shall consist of applying a concentrated dye solution around the manhole frame. Dyed water shall be applied for at least ten minutes.
- b. Manholes observed to be actively leaking will have failed the test and will not be acceptable. The Contractor shall make the necessary repairs at no additional compensation. The manhole shall then be retested as described above until a successful test is made.

D. Measurement and Payment

No contract unit prices are established for manhole testing. However, specific sections of the Contract Documents indicate that certain percentages of various contract prices will not be eligible for payment unless testing has been performed.

END OF SECTION D1-7

D1-8 SANITARY SEWER REPAIR TESTING

A. General

1. Scope

This section describes sewer repair testing required to effectively confirm the watertight integrity of sewer lines following sanitary sewer point repairs.

2. Description

All repaired sewers shall be tested by the Contractor to determine if infiltration and inflow have been eliminated through rehabilitation work. The testing required shall be as designated by the Engineer and documented to the satisfaction of the Engineer.

Internal television inspection during high groundwater conditions shall be performed on all repaired sewer line segments, after backfilling has been completed, to verify the adequacy of the sewer pipe rehabilitation work.

B. Materials

Not specified.

C. Execution

1. Sewers with selected sewer repairs shall be internally televised with a color camera while Jetting the backfill to simulate high groundwater conditions to determine the adequacy of each repair. TV inspection of point repairs is limited to the area of repair only, not the entire line segment. In areas where the repaired sanitary sewer section crosses an existing storm drain or ditch, flooding of the storm drain (using suitably sized pneumatic or mechanical pipeline plugs) or ditch section shall be required along with concurrent internal televising of the sanitary line segment. Video recording of the entire sewer line segment shall be provided to the Engineer.

2. Acceptable Limitations for Acceptance

The following observations shall be utilized to determine if repairs are inadequate or improper.

- 1) Leaking joints greater than one (1) drip per five (5) seconds.
- 2) Offset or misaligned joints where the entire pipewall thickness or greater than 1/4" offset is seen.
- 3) Cracked or broken pipe
- 4) Poor grade

5) Any other defects determined unsafe or hazardous by the engineer

4. Video recordings shall become the property of the Owner following completion of construction. If the repair of the defect is determined to be improper or inadequate by the Engineer the Contractor shall again repair the defect at no additional compensation.

D. Measurement and Payment

No Contract Prices are established for Sanitary Sewer Repair Testing. However, specific sections of the Contract Documents indicate that certain percentages of various Contract prices will not be eligible for payment unless testing has been performed.

END OF SECTION D1-8

D1-10 TRENCH SAFETY SYSTEM

A. General

1. Scope

This section describes the trench safety requirements for construction of sanitary sewers and appurtenances in accordance with the Contract Documents.

2. Description

The latest version of the U.S. Department of Labor, Occupational Safety and Health Administration Standards, 29 CFR Part 1926, Subpart P-Excavations shall be the minimum governing requirements for trench safety.

3. Trench Protection

Protect open cut trenches against collapse as required by State or Federal Laws governing the protection of life or property. Minimum protection shall conform to the recommendations of the Occupational Safety and Health Administration Standards (OSHA) for construction.

B. Materials

Not Specified.

C. Execution

The apparent low bidder shall be required to submit a site-specific trench safety plan prepared, seal, signed, and dated by a professional engineer registered in the State of Illinois. The trench safety plan shall specify the method or methods of trench safety to be used with specific information given for each so that it is clear what is required to meet governing requirements for trench safety. The submittal of the trench safety plan to the Owner and Engineer is for information only. The submittal of the trench safety plan in no way relieves the contractor from his responsibility for trench safety.

D. Measurement and Payment

Payment for the trench safety system shall be at the included in the price for repairs. This item includes costs for design of the trench safety system, all material, equipment, labor, and sub-surface investigation necessary to design and implement the trench safety system.

END OF SECTION D1-10

D1-11 ENVIRONMENTAL SPECIFICATION

A. General

Contractor shall comply with EPA storm water regulations at 40CFR 122.26 that require National Pollutant Discharge Elimination System (NPDES) permits for storm water discharges from construction activities. The permitting requirement applies to sites where activities began after October 1, 1992, and result in a surface disturbance that exceeds one acre. As a requirement of the general permit, controls to reduce pollutant loading in storm water shall be developed and implemented.

B. Objectives

By definition, Best Management Practices (BMPs) are schedules of activities, prohibition of practices, maintenance procedures, and other management practices to prevent or reduce the pollution of waters of the State. BMPs also include treatment requirements, operating procedures, and practices to control site runoff, spillage or leaks, sludge or waste disposal, or drainage from raw material storage. BMPs can be structural (such as a temporary retention pond) or non-structural (such as materials handling practices).

C. Regulatory References

1. IEPA GENERAL NPDES PERMIT NO. ILR10

D. Contractor Requirements

1. The contractor shall comply with all provisions set forth in the General NPDES Permit for Storm Water Discharges From Construction Site Activities.

E. Contractor Submittals

1. Submittals
2. Prior to commencement of construction activities, the Contractor shall provide the following submittals to the City of Mascoutah within 10 days of the Bid Opening.
 - a. The specific intended sequence of major construction activities.
 - b. Contact information for Contractor's designated spill coordinator.
 - c. Projected oil/fuel inventory and volume of containers having capacity of 55 gallons or more including equipment fuel tanks. This shall include projected oil/fuel inventory of all subcontractors.
 - d. Contractor Certification(s) of Master Comprehensive BMP Plan and applicable Addendum Comprehensive BMP Plan.

- e. Contractor local or on-site contact information.
- f. Subsequent to commencement of construction, Contractor shall submit approved copies of the General NPDES Permit No. ILR10.

F. Spill Prevention Control and Countermeasures Plan Certification and Implementation

3. Spills

- a. Should Contractor maintain onsite, an aggregate storage capacity of oil or oil products exceeding 1,320 gallons, Contractor shall be responsible for Professional Engineer Certification of Spill Prevention Control and Countermeasures Plan contained within Master Comprehensive BMP Plan.
- b. Any container, including drums, equipment fuel tanks, above ground storage tanks (ASTs), and fluid reservoirs, having a storage capacity of 55 gallons or more for oil or oil products shall be counted toward the 1,320-gallon threshold.
- c. Should Contractor's aggregate storage capacity of oil or oil products not exceed 1,320 gallons, Contractor shall be responsible for implementation of Spill Prevention Control and Countermeasures Plan contained within Master Comprehensive BMP Plan, without Professional Engineer Certification of the Plan.

END OF SECTION D1-11

TABLE OF CONTENTS FOR SPECIFICATIONS

DIVISION 2

SITE WORK

INDEX

D2-1	SITE PREPARATION
D2-3	REPLACEMENT OF MANHOLE FRAME AND GRADE ADJUSTMENTS
D2-4	SEALING OF MANHOLE FRAME AND GRADE ADJUSTMENTS
D2-5	COMPLETE AND PARTIAL REPLACEMENT OF MANHOLES
D2-6	SANITARY SEWER MANHOLES, FRAMES, AND COVERS
D2-9	EXCAVATION
D2-10	BACKFILL
D2-11	ABANDONMENT OF SANITARY SEWERS
D2-12	CURED-IN-PLACE PIPE (CIPP)
D2-12A	POST-REHABILITATION SANITARY SEWER CCTV INSPECTION
D2-13	SANITARY SEWER CONSTRUCTION
D2-14	SERVICE CONNECTION REPAIR
D2-17	RESTORATION
D2-18	TREE PROTECTION AND PRUNING
D2-20	MOBILIZATION
D2-21	BYPASS PUMPING
D2-22	TRAFFIC CONTROL
D2-23	STEEL ENCASMENT PIPE / CARRIER PIPE INSTALLATION
D2-24	SPRAY APPLIED MANHOLE COATING
SP-1	CIPP POINT REPAIR
SP-2	PROTRUDING TAP REMOVAL
SP-3	OPEN-CUT POINT REPAIR

SP-4 LATERAL REINSTATEMENTS
SP-5 AIR TEST AND GROUT SERVICE CONNECTIONS

D2-1 SITE PREPARATION

A. General

1. Clear areas necessary for performance of the work and confine operations to that area provided through easements, licenses, agreements, and rights-of-way. Entrance upon any lands outside of that area provided by easements, licenses, agreements, or public rights-of-way, shall be at the Contractor's sole liability.
2. Do not occupy any portion of the project site prior to the date established in the Notice to Proceed without prior approval of the Owner.

B. Materials

Not specified

C. Execution

1. General

Remove, relocate, reconstruct or work around natural obstructions, existing facilities and improvements encountered during site preparation as herein specified. Take care while performing site preparation work adjacent to facilities intended to remain in place. Promptly repair damage to existing facilities. Dispose of waste materials in a lawful manner off the work site.

2. Surface Obstructions

- a. Saw cut obstructions in straight lines or remove it to the nearest construction joint if located within five feet of the centerline of the trench. In no case shall the joint or line of cut be less than one foot outside the edge of the trench. Reconstruct surface obstructions removed to permit construction as specified and to the dimensions, lines and grades of original construction. Restore damaged utilities as required by the utility company at no additional cost to the Owner.
- b. Protect, move, or brace public and private utilities as specified in Section D1-5.
- c. Maintain mailboxes in the manner that the Postal Service requires in order to prevent interruption of mail delivery.
- d. Site preparation includes the removal of trees, shrubs, brush, crops, and other vegetation within the limits of the easements (right-of-way), or as may be provided for in licenses, permits and agreements. All efforts shall be made to retain existing landscaping. In the event that trees, shrubbery, and hedges cannot be saved, then prior approval of the Owner and/or the Owner's Representative must be obtained before the existing landscaping is removed.

1) Trees

All trees shall be saved unless removal is approved by the Owner and/or the Owner's Representative. Trim trees in accordance with the Owner's instructions.

2) Shrubbery

Shrubbery shall be saved unless removal is approved by the Owner and/or the Owner's Representative. Make reasonable efforts to save all shrubbery by trimming, in accordance with acceptable pruning practices, and treating wound surfaces with a commercial pruning compound.

3) Small Plants and Flowers

At least two weeks prior to the start of construction notify property owners of the proposed starting date so that the property owners can remove any small plants or flowers.

- e. Fences interfering with construction, and located within public rights-of-way or as may be allowed for in permits or agreements, may be removed only if the opening is provided with a temporary gate which will be maintained in a closed position except to permit passage of equipment and vehicles, unless otherwise herein specified. Fences within temporary construction easements may be removed provided that temporary fencing is installed in such a manner as to serve the purpose of the fencing removed.

Fencing removed shall be restored to the condition existing prior to construction unless otherwise specified. The Contractor is solely liable for the straying of any animal's protected or corralled or other damage caused by any fence so removed.

f. Private Sewer Facilities

Make every reasonable effort to protect private sewer facilities. Private sewer facilities are not shown on the Plans. When these facilities are disturbed or damaged by the work, make necessary repairs to the facilities to maintain continuous service prior to the close of the work day at no additional cost to the Owner.

g. Property Pins

Preserve property corners, pins and markers. In the event any property corners, pins, or markers are removed by the Contractor, such property points shall be replaced at the contractor's expense and shall be re-set by competent surveyors properly licensed to do such work. In the event such points are section corners or Federal land corners, they shall be referenced and filed with the appropriate authority.

h. Sodded and Landscaped Areas

Minimize disturbance to sodded and/or landscaped thoroughfares and areas on or adjacent to improved property. Do not use such areas as storage sites for

construction supplies and insofar as practicable, keep free from stockpiles or excavated materials.

3. Subsurface Obstruction

- a. Where existing utilities and service lines are encountered, notify the Owner thereof at least 48 hours (not including weekends and/or holidays) in advance of performing any work in the vicinity. Excavate, install pipeline and backfill in the vicinity of such utilities in the manner required by the respective Owner and, if requested, under his direct supervision. The Contractor shall be responsible for damages to a public or private utility that may occur as the result of the construction.
- b. Protect, move, or brace public and private utilities as specified in Section D1-5.
- c. Make a reasonable effort to ascertain the existence of obstructions and locate obstructions by digging in advance of machine excavation where definite information is not available as to their exact location. Where such facilities are unexpectedly encountered and damaged, notify responsible officials and other affected parties and arrange for the prompt repair and restoration of service.

D. Measurement and Payment

No contract prices are established for Site Preparation.

END OF SECTION D2-1

D2-3 REPLACEMENT OF MANHOLE FRAME AND GRADE ADJUSTMENTS

A. General

1. Description

This section describes replacement of existing defective manhole frame grade adjustments and the installation of new adjustments where existing manholes must be raised.

B. Materials

1. Pre-cast Concrete Adjustment Rings

- a. Pre-cast concrete grade adjustment rings and flattops shall conform to the requirements of ASTM C-478 and shall be one continuous structure. To accommodate steep surface grades, non-uniform pre-cast adjustment rings may be manufactured so that they are two-inches deep on one side and three-inches deep on the opposite side. In no instance may any non-uniform pre-cast adjustment rings be less than two-inches thick or be of multiple piece construction. Adjustment rings of uniform thickness shall be at least two inches thick.
- b. The replacement pre-cast grade adjustments shall provide a structural capacity equal to or greater than the existing or specified manhole frame, and shall not affect the opening size or surface appearance.
- c. Cracked or multiple piece pre-cast concrete grade adjustment rings will not be accepted.

C. Execution

1. Existing Grade Adjustment Rings

- a. Existing grade adjustment rings constructed of pre-cast concrete may be reused provided they are not cracked and are in otherwise good condition.
- b. Existing frame grade adjustments that are constructed of brick, block, or materials other than pre-cast concrete rings shall be replaced.

2. Seal frame and grade adjustments in accordance with Section D2-4.

D. Measurement and Payment

1. Cost of all items included in this section shall be considered incidental to the manhole replacement.
2. Payment for sealing of the frame and grade adjustments shall be incidental to the manhole replacement.

END OF SECTION D2-3

D2-4 SEALING OF MANHOLE FRAME AND GRADE ADJUSTMENTS

A. General

1. Scope

This section governs the materials required and construction procedures for sealing manhole frames and grade adjustments.

B. Materials

1. Bitumastic Gasket Material

Bitumastic gasket material shall meet or exceed Federal Specification SS-S-210A. The material shall show no signs of deterioration for a period of 30 days when immersed in solutions of acid, alkali or saturated hydrogen sulfide. Joints shall show no sagging when tested at 135F for a period of five days. Bitumastic Gasket Material shall be EZ-STIK or approved equal. Trowelable bitumastic material shall be GS-702 compound or equal.

2. Pre-cast Grade Adjustments and Flattops shall be as specified in Section D2-3.

3. Concrete Bonding Agent

Bonding agent shall be Acyrl #60 as manufactured by the Thuro-Seal Company or equal.

4. Portland Cement Concrete

As specified in Section D2-17.

5. Polyethylene

Minimum thickness of 4 mils.

C. Execution

1. Excavation

a. Non-paved Areas

Excavate adjacent to the manhole to expose the entire frame to a minimum depth of 6-inches below the top of the structurally sound structure. Limit excavation to a 6-foot by 6-foot work area. The sides of the trench shall not deviate from the vertical for more than 1/2 inch for each foot of depth.

b. Paved Areas

Make a square or rectangular full depth saw-cut and remove the pavement by breaking out from the saw-cut toward the manhole to avoid breaking the frame. Do not use pavement breaking equipment in the saw-cut. Frames broken during excavation shall be replaced at the Contractor's expense. Excavate the work area to expose the entire frame to a minimum depth of 6-inches below the top of the structurally sound structure.

2. Sealing Procedure

- a. Remove manhole frame from the manhole structure. Separate and observe the condition of the grade adjustments. If the grade adjustments are loose, deteriorated, broken, or show structural defects replace them in accordance with these Specifications. Replace adjustments that are constructed of brick, block, or materials other than pre-cast concrete rings with pre-cast concrete rings, or where necessary, and approved by the Owner's Representative, a pre-cast flattop section. Pre-cast concrete and rubber rings, or a pre-cast concrete flattop sections will be the only adjustments allowed.
- b. Wire brush manhole frame and exposed manhole surfaces to remove dirt and loose debris. Coat exposed manhole surfaces with an approved bonding agent followed with an application of a quick setting hydraulic cement to provide a smooth working surface as thin as possible.
- c. If the inside diameter of the manhole is too large to safely support new adjustments or frame, then a flattop section shall be installed.
- d. Joint surfaces between the frame, adjustments, and cone section shall be free of dirt, stones, debris, and voids to ensure a watertight seal. Place a flexible gasket joint material, minimum 1/2 inch thick, in two concentric rings along the inside and outside edge of each joint. Position the butt joint for each length of joint material on opposite sides of the manhole. No steel shims, wood, stones, or any material not specifically accepted by the Owner's Representative may be used to obtain final surface elevation of the manhole frame. If minor elevation adjustment is required to match the existing pavement surface, quick setting mortar such as Hyperform as manufactured by Quadex or approved equal shall be used to adjust the elevation.

- e. When pre-cast concrete grade adjustment rings are placed on the manhole structure to obtain proper grade, no more than 24 vertical inches may be used, unless approved by the Owner's Representative.
- f. In paved areas or future paved areas, castings shall be installed by using a straight edge not less than ten (10) feet long so that the top of casting will conform to the slope and finish elevation of the paved surface. The top of the casting shall be 1/8 inch below the finished elevation. Allowances for the compression of the joint material shall be made to assure a proper final grade elevation.
- g. Manhole rims in parkways, lawns and other improved lands shall be at an elevation not more than one (1) nor less than one-half (1/2) inch above the surrounding ground. Backfill shall provide a uniform slope from the top of manhole casting for not less than three (3) feet each direction to existing finish grade of the ground. The grade of all surfaces shall be checked for proper slope and grade by string lining the entire area re-graded near the manhole.
- h. Manholes in open fields, unimproved land, or drainage courses shall be set as required by the Owner's Representative.
- i. On non-paved manholes, exterior surfaces of all exposed grade adjustments and four inches below sound structure shall be cleaned with a wire brush and then waterproofed with trowelable bitumastic gasket material in accordance with the manufacturer's specifications. A protective polyethylene cover shall be placed over the waterproofing material when backfilling, following sealing of the frame and grade adjustment.

Concrete grade rings shall be wrapped with a heat-shrink thermo-plastic material.

3. Backfill

a. Non-paved

Excavated material subject to review of the Engineer shall be used for backfill and mechanically compacted following sealing of the frame and grade adjustments. Bentonite may be added to backfill at the Contractor's discretion. The level of the backfill shall be to one inch above the frame bottom with the removed topsoil being placed on top of the compacted impervious backfill prior to replacement of sod.

b. Paved

Portland cement concrete (Section D2-17) shall be used for backfill following sealing and testing of the frame and grade adjustments to prevent compaction of the joint material and extend to 6 inches below the top of structurally sound structure as shown on the Detail for Manhole Restoration.

4. Restoration

Restore surfaces in accordance with Section D2-17. Grassed areas shall be replaced with sod to match existing conditions. Pavement replacement shall match existing pavement material. Restoration of all surfaces will not be paid for separately.

5. Testing of Rehabilitated Frame and Grade Adjustment Seals.

Test rehabilitated frame and grade adjustment seals for watertightness in accordance with Section D1-7.

D. Measurement and Payment

Cost of all items included in this section shall be considered incidental to the manhole replacement item.

The cost of these items shall include all labor and equipment necessary to complete the work described, including, but not limited to, saw-cut, pavement removal, excavation, sealing of manhole frame and adjusting rings, backfill, testing, pavement repair, seed, and sod. The cost of grade adjustment materials shall be paid in accordance with Section D2-3.

END OF SECTION D2-4

D2-5 COMPLETE AND PARTIAL REPLACEMENT OF MANHOLES

A. General

1. Description

This section describes complete and partial replacement of manholes and the removal and replacement of flattops.

B. Materials

1. Pre-cast concrete manholes shall be bell and spigot with "O" ring joints. Manholes and sections shall conform to the requirements of ASTM C-478 and shall be as specified in this section and in construction plan details.
2. All complete replacement manholes shall have watertight frame and cover, with a minimum 30-inch clear opening, as manufactured by NEENAH.
3. Exterior surfaces of manhole sections shall be coated with two mop coats of coal tar epoxy paint, Kop Coat "Bitumastic Black Solution", Tnemec, "46-450 Heavy Tnemecol", or equal. Dry film thickness shall be a minimum of 14.0 mils per coat. Recoating shall be done in accordance with manufacturer's recommendations.
4. For new manholes, entire interior and underside of flattops to have 5 mil DFT Polibrid 672 primer and 75 mil DFT Polibrid 705 topcoat, or 80 mil coat of "Raven" self-priming epoxy coating, or an 80 mil coat of "Spraywall".
5. Opening for each connecting pipe shall be circular with a compression type flexible rubber gasket cast integrally into the manhole wall. Flexible gaskets shall be manufactured in accordance with rubber joint specification ASTM C923 and shall meet the performance and test requirements of ASTM C 425 for compression joints. Flexible gaskets shall include a coupling with O-Ring Gasket, A-Lok, Presswedge, or equal.
6. Preformed and trowelable bitumastic joint sealants shall be EZ-STIK, or equal. The minimum dimension of preformed material shall be one-half (1/2) inch square. Pre-cast concrete grade adjustment rings shall conform to the requirements of ASTM C-478 and shall be one continuous structure. To accommodate steep surface grades, non-uniform pre-cast adjustment rings may be manufactured so that they are two-inches deep on one side and three-inches deep on the opposite side. In no instance may any non-uniform pre-cast adjustment rings be less than two-inches thick or be of multiple piece construction. Adjustment rings of uniform thickness must be at least two inches thick.
7. Backfill shall be in accordance with Section D2-10.
8. Non-Shrink Grout

Grout shall be non-shrink in the plastic state and show no expansion after set as tested in accordance with ASTM C 827 and shall develop compressive strength not less than 3,000

psi with a trowelable mix within 24 hours per ASTM C 109. The placement time shall be not less than 45 minutes based on initial set per ASTM C 191. Test results shall be furnished by the manufacturer and submitted to the Engineer.

9. Steps

- a. Manhole steps will not be required.

10. Cast-In-Place (Monolithic) Concrete Manholes

The design of standard manholes shall be per the Standard Manhole Detail Drawings.

- a. Pipe extending from the manhole shall be cradled in concrete to the first pipe joint in the same pour as the manhole foundation. Embedment of reinforcing steel shall extend not less than twenty (20) bar diameters into manhole base.
- b. A minimum of six (6) inches embedment material according to Section D2-10 shall be used beneath manhole foundations. Where trench has been over-excavated, the void created shall be completely filled with a trench foundation material according to Section D2-10 to the underside of the manhole base.
- c. In the event that ground water is present during the pouring of a cast-in-place manhole foundation, a pump shall be used to remove the ground water. Prior to pouring, the sub-grade shall be stable, free from muck and groundwater. After the concrete foundation has been placed, the pump shall continue to run for at least two (2) hours to enable the concrete to obtain its initial set.
- d. Cast-in-place concrete manholes shall have a minimum inside diameter at the base of four (4') feet and an inside diameter at the top of the concentric cone section of not less than thirty (30") inches unless specified otherwise herein. The manhole shall have a minimum wall thickness of six (6") inches for 4' diameter manholes and 8" for 5' diameter manholes and shall be smooth having no form marks on the interior wall or exterior wall of the manhole exceeding one-quarter (3") inch in depth. Concrete used for the manhole barrel and cone section shall be a minimum compressive strength of 4000 psi at 28 days, with a slump of five (5") inches to seven (7") inches during the placement. Concrete shall not be so dry as to cause extensive honeycombing. During the placement of the concrete in the manhole barrel forms, thorough vibrating shall be completed at two (2') foot intervals. If cold joints are necessary because of a time lapse of more than one hour between placements then a concrete bonding adhesive shall be applied to the existing concrete. A concrete collar at least four (4") inches thick shall extend a minimum of eight (8") inches above and below the new joint around the outside of the manhole. If honeycombing of the barrel of the manhole is found to be present after removal of the forms, such honeycombing shall be repaired as directed by the Engineer. Any form marks on the inside wall shall be smoothed and grouted as directed. Curing compounds or covers may or may not be used at the option of the Contractor to protect the concrete to prevent cracking during the curing process and to protect the manhole during freezing temperatures. The manhole shall not be backfilled for at least two (2) working days after forms have been removed or a minimum of three (3) working days after the concrete has

been placed.

- e. Reinforcing steel used in design of reinforced manhole foundations shall conform to ASTM A 615, Grade 60, deformed bars.
 - f. Welded steel wire fabrics for cast-in-place manholes shall conform to ASTM 185.
 - g. Manholes bases shall be integral cast. The diameter of the integral base pad shall be eight (8) inches greater than outside diameter of the manhole.
 - b. Base slab depth and 3/4" washed rock gravel depth shall be minimum as shown in Table 1 of standard detail drawings, but in all cases, base slab shall be designed for H-20 loading, plus earth load at 130 p.s.f.
11. Shallow manholes shall be constructed at locations in the sanitary sewer system where depths are less than four feet, or as directed by the Engineer. If this is needed, details and specific requirements will be provided by the Engineer.
12. Pre-cast Concrete Manhole Sections
- a. Manholes shall conform to ASTM C 478 and as specified herein.
 - b. Wall thickness shall be minimum 6" for all pre-cast sections for 4' diameter manholes and 8" for 5' diameter manholes.
 - c. Reinforced concrete flattop sections shall have a minimum 30-inch diameter opening and be a minimum eight inches thick in non-traffic areas and a minimum ten inches thick in traffic areas (designed for HS-20 loading). Reinforce flat-top sections with #4 bars at 12-inch centers each way. Tie and place reinforcing steel below the mid point. The minimum cover over the reinforcement shall be two (2) inches. The top or bottom of the flattop shall be clearly labeled or marked.
 - d. Openings for each connecting pipe shall be circular with a compression type flexible rubber gasket cast integrally into the manhole wall. Flexible gaskets shall be manufactured in accordance with rubber joint specification ASTM C923 and shall meet the performance and test requirements of ASTM C 425 for compression joints. Flexible gaskets shall include a coupling with O-Ring Gasket, A-Lok, Presswedge, or equal.
 - e. Preformed and trowelable bitumastic joint sealants shall be Kent-seal, Ram-Nek, EZ-STIK, or equal. The minimum dimension of preformed material shall be one-half (1/2) inch square.
 - f. Do not deliver pre-cast concrete sections to the job until representative concrete cylinders have attained a strength of at least 80 percent of the specified minimum. Inspect pre-cast concrete sections when delivered. Cracked or otherwise visibly defective units will be rejected.
 - g. The maximum depth of lifting holes shall be no more than one-half the manhole

wall thickness. After placement of the manhole, the lifting holes shall be sealed with a non shrink grout.

- h. Contractor is responsible for verifying all manhole depths and sewer pipe flowlines prior to delivery of pre-cast manholes. The contractor will be responsible for removing and replacing any manhole that is not properly fitted to the sewer grades at the existing site.

13. Flattop Sections

- a. Manholes may have a flat lid, if approved by the City of Mascoutah, being 12-inch thick with a minimum 30-inch opening, as manufactured an approved manufacturer. Manhole frame grout. conforming to ASTM C478, 5000 psi concrete, traffic bearing, and O-ring joint conforming to ASTM C443.

C. Execution

1. General

Install manholes of the respective types at the designated locations with flowlines at elevations to match existing.

- 2. Interior manhole diameters unless otherwise noted shall be 48 inches for pipe between 6 inches and 24 inches in diameter and 60 inch manhole will be constructed for 27 inches and 36 inches in diameter, and 84 inches in diameter for pipe between 42 and 48 inches in diameter.

- 3. Install frames and covers in accordance with the Specifications and Detail Drawings in the construction plans.

- 4. Form inverts with mortar material and steel-trowel to produce a dense, smooth finish and shape to form a "U"- shaped channel extending to the crown of the pipe encompassing the full cross section of the connecting pipelines. Provide smooth transitions for pipes of different sizes, different elevations, and/or at different angles. Also form inverts to provide self-cleaning by sloping normally with a 1:2 slope.

5. Existing Pipe Connections

The replacement of manholes shall include the replacement of five (5) feet of all existing sewer lines. The sewer lines shall be connected in accordance with this section. Pipe embedment and backfill shall be in accordance with Section D2-10 of these Specifications.

6. Pipe Stubs

- a. Install pipe stubs for future connections at locations, angles, elevations, and of materials as specified or as determined by the Engineer.
- b. Install each pipe stub with the bell of the pipe abutting the outside manhole wall,

or the joint if other than a bell, as near the manhole wall as is practicable but not more than two (2) feet from outside manhole wall for later connection thereto.

7. Pipe holes at manholes shall be permanently sealed watertight with non-shrink grout after installation of the connecting pipelines. The grout shall provide a smooth transition from the pipe to the manhole wall.
8. Construct connections to existing manholes in conformance with this section. Excavate around the existing manhole so as not to disturb the manhole. The manhole wall shall be removed for no greater diameter than required to insert new pipe. Reshape manhole invert and channel to accept the flows from the new pipe. Chip the existing invert to a rough new surface and install a new channel and invert the entire side where the new pipe enters. Take care to prevent brick or other foreign material from entering the existing downstream sewer. Retrieve such debris. After the new pipe is installed, completely fill and render permanently watertight the void around the new pipe with a non-shrink grout conforming to the material specifications herein.
9. Manhole Adjustments

Provide new manholes with a maximum of one (1) foot of adjustment ring(s) underneath the casting. Refer to typical manhole detail. Grade ring shall be wrapped with a heat-shrink thermo-plastic material.
10. Apply two coats of coal-tar epoxy paint to the manhole exterior. Coating shall be in accordance with Manufacturer's recommendation.
11. Testing

Test manholes in accordance with Section D1-7. Concrete testing for poured-in-place manholes consist of a minimum of one slump test and three concrete cylinders per truckload of concrete used for the manholes and collars. One cylinder shall be tested for compressive strength at seven days, one at twenty-eight days, and one shall be a spare. All sewer pipes replaced in conjunction with the manhole replacement, including the 5 lf section shall be cleaned and televised, and tested in accordance with Section D1-8.
12. Formwork
 - a. Vertical concrete surfaces shall be formed. The underside of slabs and beams shall be formed except where the concrete is placed against the ground. Sloping surfaces shall be formed unless otherwise authorized by Engineer.
 - b. Construct and erect forms so that the concrete will have the shape, line, and grade indicated. Make forms mortar tight and sufficiently rigid to prevent deformation under load. Use an adequate number of walers, stiffeners, and braces to insure straight walls.
 - c. Formwork, shoring, and bracing design shall meet the requirements of ACI 347.
 - d. Except as noted, tolerances for formed surfaces shall meet the requirements of ACI 301. Edges of form panels in contact with concrete exposed to view in the finished work shall be flush within 1/32 inch. Forms for plane surfaces shall be

such that the concrete will be plane within 1/8-inch in four ft. Leading edges of concrete shall lie within 1/4-inch as measured from a 10-ft template.

- e. Provide as-cast smooth form finish for formed concrete surfaces that are to be exposed to view, or that are to be covered with a coating material other than cement plaster applied directly to the concrete.
- f. Produce smooth form finish by selecting form material to impart a smooth, hard, uniform texture and arranging them orderly and symmetrically with a minimum of seams.
- g. Repair and patch defective areas with all fins and other projections completely removed and smoothed.

13. Reinforcement

- a. Reinforcing steel shall be placed in accordance with ACI 301 and ACI 318. When concrete is placed, reinforcing shall be free of rust, scale, or other coatings that will affect the bond. Reinforcement shall be accurately placed, adequately supported, and secured in position at intersections with annealed wire not less than 16-ga or with clips. Reinforcement shall be supported to keep it away from exposed surfaces. Nails or other devices shall not be driven into forms to support reinforcement.
- b. Provide the following concrete cover unless otherwise shown on the drawings:

Bottom face of slabs	1 inch
Top face of slabs	1 1/2 inches

14. Placing Concrete

- a. General
 - 1) Do not place concrete until forms have been oiled, reinforcement has been fastened in position, form ties at construction joints have been retightened, and embedments and openings have been placed and anchored.
 - 2) Remove debris from the space in which concrete is to be placed.
- b. Convey concrete from the mixer to the place of final deposit by methods which will prevent separation or loss of materials. The free fall of concrete shall not exceed three feet.
- c. Consolidating
 - 1) Consolidate concrete with mechanical vibrating equipment and provide stand by equipment. Apply vibration directly to the concrete. Vibration shall be sufficient to cause flow or settlement of the concrete into place. Apply vibration at the point of deposit and in the freshly placed concrete. It shall be of sufficient duration to accomplish compaction and embedment of reinforcement and fixtures.

- 2) Supplement vibration by forking and spading by hand in the corners and angles of forms and along form surfaces while the concrete is plastic under the vibratory action.

15. Curing

- a. Maintain concrete in a moist condition for seven days after placement. Curing may be by any of the following means:
 - 1) Curing with burlap, cotton, or mats kept continuously wet, or by keeping forms continuously wet.
 - 2) Waterproof paper curing. Overlap four inches at seams and seal with tape.
 - 3) Membrane curing by power spraying with a fugitive dye included. Do not use this method on surfaces which will receive a finish treatment of any kind. Submit manufacturer's descriptive data of curing compounds for approval.

16. Complete Manhole Replacement

- a. Manholes designated for complete replacement shall be completely reconstructed using cast-in-place. The existing manhole structure shall be completely removed prior to installation of the new structure.
- b. The Contractor shall remove all debris and prevent any material from entering the sewer line. Debris shall be taken to a landfill or dump site approved by the Owner.
- c. All sanitary and storm pipe damaged during excavation shall be replaced at no additional compensation unless otherwise noted.
- d. Any incoming pipes which are 2 feet or more above the outgoing invert elevation shall be equipped with outside drop connections.
- e. Complete manhole replacement shall also include replacement of frame, cover, bench/trough, sealing of frame, replacement of sewer line within five (5) lineal feet outside of the manhole, frame and grade adjustments, and surface restoration. Replacement pipe of the 5 lf section shall be of the same size and type as existing pipe. Connection of the 5 lf of new pipe to the existing pipe shall be in accordance with applicable sections.

Where determined by the engineer that a good connection can not be made, the contractor will be paid for additional footage outside of the five (5) lineal feet covered by the complete manhole replacement bid item and be paid for at the unit price per lineal foot for additional pipe.

All newly constructed manholes shall have an concentric cone per concentric concrete detail in detail drawings.

All manhole covers shall be 32-inches in diameter and bolted and gasketed when located outside of pavement unless otherwise specified by the Engineer.

17. Partial Manhole Replacement

Not applicable to this contract.

18. Flattop Replacement

- a. Existing flattops found to be defective shall be replaced.
- b. Excavate the work area to expose the entire depth of the existing flattop to a minimum depth of 6 inches below the top of the flattop.
- c. Perform reconstruction to allow easy access to the manhole. No more than 12 inches of depth of pre-cast concrete grade adjustment rings shall be allowed to obtain proper grade.
- d. Seal flattops in accordance with Section D2-4.
- e. Flattop replacement shall include excavation, replacement of frame, cover, sealing of frame, frame and grade adjustments, and surface restoration.
- f. Remove any debris in any manhole that has had work performed on it.

19. Shallow manholes shall be constructed at locations in the sanitary sewer system where depths are less than four feet, or as directed by the Engineer. Shallow manholes shall be constructed from 4000 psi concrete, formed in place as shown in details.

D. Measurement and Payment

Any items not listed below shall be included in the unit or lump sum prices for the item affected thereby.

1. Standard Manhole

The manhole depth shall be determined by measuring from top of casting to the invert at the center of the manhole. Payment will be made at the contract unit price for the applicable type, size and depth for each manhole. Such payment and price shall constitute full compensation for all labor, materials, equipment and for the performance of all work necessary to complete the manholes, including removal of existing manhole, excavation, concrete base, manhole frame and cover, frame and cover grade adjustment and sealing, waterproofing, concrete masonry, reinforced concrete, backfilling, replacement of any sewers, conduits, disposal of excess material and restoration.

2. Partial Manhole

Not Applicable to this Contract.

3. Flattop

Flattop replacement shall be incidental to the complete and partial manhole replacement item. Cost of flattop replacement shall include all labor, materials, equipment and for the performance of all work necessary to complete the manholes, including removal of existing flattop, excavation, sealing of flattop, manhole frame and cover, frame and cover grade adjustment and sealing, waterproofing, concrete masonry, backfilling, surface restoration, and disposal of excess material.

4. Additional Sewer Pipe

Additional sewer pipe cost shall be incidental to the complete and partial manhole replacement item.

6. The Unit Price for complete and partial manhole replacement shall be eligible for 60 percent of the bid price after the repair is made, an additional 10 percent is eligible after testing is complete and an additional 30 percent is eligible after restoration is complete.

END OF SECTION D2-5

D2-6 SANITARY SEWER MANHOLES, FRAMES, AND COVERS

A General

1. Description

This section specifies construction of sanitary sewer manholes.

5. Submittals

Make submittals in conformance with Section D1-3 - Submittals.

Provide submittals to show conformance with this specification for the following items.

1. Manhole Risers

2. Manhole Frames and Covers

3. Joint Seal Material

4. Precast manhole section information if precast sections are used.

5. Manhole to pipe interface – boot or gasket

6. References

ASTM A48/A48M-03 – Standard Specification for Gray Iron Castings.

ASTM A185 - Steel Welded Wire Fabric, Plain, for Concrete Reinforcement.

ASTM A325 - Specification for Structural Bolts, Steel, Heat Treated, 120/105 ksi Minimum Tensile Strength.

ASTM A615 - Deformed and Plain Billet-Steel Bars for Concrete Reinforcement.

ASTM C109 – Compressive Strength Hydraulic Cement Mortars.

ASTM C191 - Time of Setting of Hydraulic Cement by Vicat Needle.

ASTM C425 – Compression Joints for Vitrified Clay Pipe and Fittings.

ASTM C443-20 – Standard Specification for Joints for Concrete Pipe and Manholes, Using Rubber Gaskets.

ASTM C478 - Specification for Precast Reinforced Concrete Manholes Sections.

ASTM C827 - Standard Test Method for Change in Height at Early Stages of Cylindrical Specimens from Cementitious Mixtures.

ASTM D1056 – Standard Specification for Flexible Cellular Materials – Sponge or Expanded Rubber.

B. Products

1. MANHOLE RISERS AND SECTIONS

ASTM C478.

2. MANHOLE FRAMES AND COVERS

Material shall be cast iron, gray iron, or ductile iron conforming to ASTM A48/A48M-03, Class 35 or better. The frame shall exhibit a tensile strength of not less than 35,000 psi, and conform to the following:

2.1 Frame and Cover Design.

Designed to support H-20 traffic loading.

Bearing surfaces between the ring and cover shall be machine finished or ground to assure non-rocking fit in any position, and interchangeability.

Covers shall set flush with the rim of the frame and shall have no larger than a 1/8-inch gap between the frame and cover.

The cover shall form a water-resistant seal between the frame and manhole cover surface. The cover shall have concealed pick holes and a machined bearing surface on the bottom of the casting. The cover shall conform to ASTM A 48/A48M-03, Class 35 or better, for Gray Iron. The cover shall have a tensile strength of 35,000 psi.

2.2 Marking.

The manhole lid shall have "Sanitary Sewer" on top.

2.3 Frame Size.

Sized to fit a nominal 24-inch manhole opening.

2.4 Minimum Cover Opening.

20 inches.

2.5 Locking Type Cover.

Locking mechanism - 3 cams connected to and equally spaced around the circumference of the cover.

Cams released by unlocking hooks.

Provide at least 2 hooks for every 6 covers.

2.6 Watertight Type Cover.

The bolts for bolt down covers shall be ASTM A325 or better. They shall meet or exceed the manufacturer's recommendations as bolts for the frame and cover.

Provide a full circle rubber gasket for installation between manhole frame and cover.

Supply at least 2 operating wrenches for every 6 covers.

2.7 Hinged Cover and Frame

Hinged frame and cover shall be manufactured of ductile iron and meet or exceed AASHTO H-20 loading, and shall be Pamrex or approved equal.

The lid shall open to a minimum of 130 degrees, and block at 90 degrees when closing.

The frame shall be fitted with an Elastomer gasket to prevent inflow/infiltration.

The lid shall be fitted with a locking device that requires a specially manufactured key for removal, and will not open under pressure from surcharge.

At a minimum, provide two keys for every six covers.

2.8 Non-Locking Type Cover.

"Standard," vented, designed to support AASHTO H20 traffic loadings.

2.9 Manhole Couplings.

Rubber ring, Fernco or approved equal; Lawson Davis or approved equal.

2.10 Watertight Manhole Inserts

The manhole insert body shall be manufactured from 304 stainless steel with a thickness of not less than 18 gage, and be Rainstopper or approved equal.

The insert shall have a straight side design to allow a loose fit for easy removal, and have no fewer than three (3) ribs stamped in the bottom for added strength.

The manufacturer shall supply a load test, showing a load test failure in excess of 3000 lbs.

The manhole insert shall have a gasket that provides positive seal in wet or dry conditions. The gasket shall be made of closed cell neoprene rubber and meet the requirement of ASTM D1056, or equal.

The manhole insert shall have a strap for removing the insert. The strap shall be made of minimum 1" wide woven polypropylene or nylon webbing, with the ends treated to prevent unravelling, The strap shall be attached with #6 high grade stainless steel rivets and washers to securely attach strap to the insert. The strap shall be capable of withstanding at least 500 pounds of force before failure.

The manhole insert shall have a valve to release gases at a pressure of 0.5 to 1.5 psi, and allow water inflow at a rate no greater than 5 gallons per 24 hours.

All manhole frame and covers shall be fitted with a watertight manhole insert except a hinged cover and frame as specified in paragraph 7. above.

3. PRECAST CONCRETE SECTIONS AND BASE

Precast concrete manholes will be allowed. Manholes and sections shall conform to the requirements of ASTM C 478 and as specified herein.

- 3.1 Wall thickness shall be minimum 6" for all precast sections.
- 3.2 Concentric or eccentric cones may be utilized when manhole depth exceeds six feet. The clear opening of the cone shall be 26 inches.
- 3.3 Reinforced concrete flat-top sections shall have a minimum 26-inch diameter opening and be a minimum eight inches thick in non-traffic areas and a minimum ten inches thick in traffic areas (designed for H-20 loading). Reinforce flat-top sections with #4 bars at 12-inch centers each way. Tie and place reinforcing steel below the mid point. The minimum cover over the reinforcement shall be two (2) inches. The top or bottom of the flattop shall be clearly labeled or marked.
- 3.4 Preformed and trowelable bitumastic joint sealants shall be Kent-seal, Ram-Nek, EZ-STIK, or approved equal, ASTM C443. The minimum dimension of preformed material shall be one-half (1/2) inch square.
- 3.5 Do not deliver precast concrete sections to the job until representative concrete cylinders have attained a strength of at least 80 percent of the specified minimum. Inspect precast concrete sections when delivered. Cracked or otherwise visibly defective units will be rejected.
- 3.6 The maximum depth of lifting holes shall be no more than one-half the manhole wall thickness. After placement of the manhole, the lifting holes shall be sealed with a non shrink grout.
- 3.7 Contractor is responsible for verifying all manhole depths and sewer pipe flowlines prior to delivery of precast manholes. The Contractor will be responsible for removing and replacing any manhole that is not properly fitted to the sewer grades at the existing site.

7. CAST IN PLACE (MONOLITHIC) CONCRETE MANHOLES

The design of standard manholes shall be the responsibility of the Contractor. Shallow manholes shall be constructed as detailed on the Drawings. Sketches of all manholes indicating complete details of the proposed design shall be submitted to the Engineer for review prior to ordering material and/or construction. Cast in place construction will be considered for circular manholes only unless appropriately designed with reinforcing steel. The concrete for circular manholes shall be reinforced with wire mesh conforming with this document. The minimum sidewall thickness shall be 6 inches or one-eighth the inside diameter whichever is greater. The base thickness of manhole below the underside of flow channel shall vary, depending on the diameter, the depth of manhole, and on the type of joint occurring between base slab and wall. The minimum base thickness shall be 8 inches or 1/8 the manhole diameter plus 1/30th of the manhole depth, whichever is greater.

- 4.1 Foundations of manholes for sanitary sewer shall be concrete of a minimum compressive strength of 4000 psi at 28 days. The invert channels shall be smooth, accurately shaped, and in accordance with the drawings. Where changing line sizes occur, the crowns (top insides) of the pipe shall be matched unless otherwise approved by the Engineer. The invert of the manholes shall be shaped and smooth so that no projections will exist. Flow channels shall be formed in the inverts so that the manhole will be self-cleaning and free of areas where solids may be deposited as sewage flows through the manhole from all inlet pipes to all outlet pipes. Where the pipe can be laid continuously through the manhole, the pipe can be placed in the base. After the construction of the manhole, the pipe can be trimmed by cutting out the top half after the concrete base is constructed and has cured sufficiently. If it is not possible to lay the pipe continuously through the manhole base, the invert may be poured and formed directly in the concrete of the manhole base. The invert floor shall have a minimum slope of 1 inch per foot unless noted otherwise. The manhole invert shall extend from wall to wall. The minimum thickness for all bases shall be eight (8) inches. Reinforce bases with #4 bars at 12-inch centers each way. Tie and place reinforcing steel above the midpoint. The minimum cover over the reinforcement shall be two (2) inches. When the connecting pipelines are required to have concrete embedment, extend the embedment reinforcing steel not less than twenty (20) bar diameters into the manhole base.
- 4.2 Pipe extending from the manhole shall be cradled in concrete to the first pipe joint in the same pour as the manhole foundation. Embedment of reinforcing steel shall extend not less than twenty (20) bar diameters into manhole base.
- 4.3 A minimum of six (6) inches rock cushion shall be used beneath manhole foundations. Where trench has been over excavated, the void created shall be completely filled with a rock cushion to the underside of the manhole base.
- 4.4 In the event that ground water is present during the pouring of a cast-in-place manhole foundation, a pump shall be used to remove the ground water. Prior to pouring, the subgrade shall be stable, free from muck and groundwater.

After the concrete foundation has been placed, the pump shall continue to run for at least two (2) hours to enable the concrete to attain its initial set.

- 4.5 Cast-in-place concrete manholes shall have a minimum inside diameter at the base of four (4') feet and an inside diameter at the top of the cone section of not less than twenty-four (24") inches unless specified otherwise herein. The manhole shall be smooth having no form marks on the interior wall or exterior wall of the manhole exceeding one quarter (1/4") inch in depth. Concrete used for the manhole barrel and cone section shall be a minimum compressive strength of 4000 psi at 28 days, with a slump of five (5") inches to seven (7") inches during the placement. Concrete shall not be so dry as to cause extensive honeycombing. During the placement of the concrete in the manhole barrel forms, thorough vibrating shall be completed at two (2') foot intervals. If cold joints are necessary because of a time lapse of more than one hour between placements then a concrete bonding adhesive shall be applied to the existing concrete. A concrete collar at least four (4") inches thick shall extend a minimum of eight (8") inches above and below the new joint around the outside of the manhole. If honeycombing of the barrel of the manhole is found to be present after removal of the forms, such honeycombing shall be repaired as directed by the Engineer. Any form marks on the inside wall shall be smoothed and grouted as directed. Curing compounds or covers shall be used to protect the concrete to prevent cracking during the curing process and to protect the manhole during freezing temperatures. The manhole shall not be backfilled for at least two (2) working days after forms have been removed or a minimum of three (3) working days after the concrete has been placed.
- 4.6 Reinforcing steel used in reinforced manhole foundations shall conform to ASTM A615, Grade 60, deformed bars.
- 4.7 Welded steel wire fabrics for cast-in-place manholes shall conform to ASTM 185.
- 4.8 Manholes bases shall be integral cast. The diameter of the integral base pad shall be eight (8) inches greater than outside diameter of the manhole.

8. PIPE TO MANHOLE CONNECTOR

Openings for each connecting pipe shall be circular with a compression type flexible rubber gasket cast integrally into the manhole wall. Flexible gaskets shall be manufactured in accordance with rubber joint specification ASTM C 443 and shall meet the performance and test requirements of ASTM C 425 for compression joints. Flexible gaskets shall include a coupling with O-Ring Gasket, A-Lok, Presswedge, or equal.

9. COATINGS

- 6.1 Manhole interior epoxy coating according to Section D2-24 – Spray Applied Manhole Coatings.

- 6.2 Exterior manhole coating - coal tar epoxy paint, Kop Coat "Bitumastic Black Solution", Tnemec, "46-450 Heavy Tnemecol", or equal.

10. NON-SHRINK GROUT

Grout shall be non-shrink in the plastic state and show no expansion after set as tested in accordance with ASTM C 827 and shall develop compressive strength not less than 3,000 psi with a trowelable mix within 24 hours per ASTM C 109. The placement time shall be not less than 45 minutes based on initial set per ASTM C 191. Test results shall be furnished by the manufacturer and submitted to the Engineer.

C. Execution

1. GENERAL

Install manholes of the respective types at the designated locations with flowlines at elevations to match existing.

Interior manhole diameters unless otherwise noted shall be 48 inches for pipe between 6 inches and 24 inches in diameter, 60 inches in diameter for pipe between 27 inches and 36 inches in diameter, and 84 inches in diameter for pipe between 42 and 48 inches in diameter.

2. PREPARATION

Compaction of Earth Under Manholes.

- a. Prior to construction of the manhole, compact the ground underlying the manhole base, using a mechanical tamper, with 3 passes minimum over the entire surface.

Placement of Bedding Material.

- b. Compact bedding material with a minimum of 3 passes over the entire surface with a mechanical tamper.

3. CONSTRUCTION

Forming of Gravity Manhole Base and Invert.

- a. Form benches with mortar material and steel-trowel to produce a dense, smooth finish and shape to form a "U"- shaped channel extending to the crown of the pipe encompassing the full cross section of the connecting pipelines. Provide smooth transitions for pipes of different sizes, different elevations, and/or at different angles. Also form benches to provide self-cleaning by sloping normally two (2) inches from manhole wall to edge of "U" channel with a smooth finish. Apply final grout coat to the manhole base with a sack finish.
- b. Drop connections shall be constructed where indicated on the construction plans, and in accordance with the construction details.

- c. Apply Portland Cement grout to the joint between the sewer pipe and the manhole wall inside and out to insure a watertight seal.

Connections

Construct connections to existing manholes in conformance with this section. Excavate around the existing manhole so as not to disturb the manhole. The manhole wall shall be removed for no greater diameter than required to insert new pipe. Reshape manhole invert and channel to accept the flows from the new pipe. Chip the existing invert to a rough new surface and install a new channel and invert the entire side where the new pipe enters. Take care to prevent brick or other foreign material from entering the existing downstream sewer. Retrieve such debris. After the new pipe is installed, completely fill and render permanently watertight the void around the new pipe with a grout conforming to the material specifications herein.

Manhole Adjustments

Provide new manholes with a maximum of one (1) foot of adjustment ring(s) underneath the casting. Seal adjustment ring joints as specified in this section.

4. INSTALLATION

For cast-in-place manhole bases, place the first manhole riser section before the concrete base has taken its initial set. Bed the ring into the concrete. Apply Portland Cement grout inside and out to ensure a watertight seal.

For precast or cast-in-place manhole bases, place the manhole riser and cone sections together using full bed of Portland Joint compound or rubber gasket to ensure a watertight joint.

When using rubber gasket material, prime both ends of manhole cone and risers. Apply primer to clean and dry concrete. Install rubber gasket in accordance with manufacturer's recommendations.

Use flat slab top for manholes 5 feet or less in height, and eccentric cone section for manholes over 5 feet in height. Height, measured from centerline invert to rim elevation, will be used to determine manhole top configuration. 72-inch manholes shall have a base section that extends above the invert a minimum of five (5) feet, a reducer to 48-inches, and then an eccentric cone. Where there is insufficient depth, the manhole may be fitted with flat top. All manhole openings shall be 26-inches.

5. COATINGS

Coat all manhole interiors with epoxy according to D2-24 Spray Applied Manhole Coatings.

Exterior surfaces of all manholes shall be coated with two mop coats of coal tar epoxy paint. Dry film thickness shall be a minimum of 14.0 mils per coat. Recoating shall

be done in accordance with manufacturer's recommendations. All exterior manhole joints (including joints between grade adjustments) shall be sealed with an external rubber sleeve similar to the Infi-Shield Gator Wrap as manufactured by Sealing Systems Inc. (763-478-2057). No separate pay item.

Manholes on line segments smaller than 12-inches, not on the interceptor, will not be epoxy coated on the interior.

6. SEALING PROCEDURES

Wire brush manhole frame and exposed manhole surfaces to remove dirt and loose debris. Coat exposed manhole surfaces with an approved bonding agent followed with an application of a quick setting hydraulic cement to provide a smooth working surface as thin as possible.

Joint surfaces between the frame, adjustments, and cone section shall be free of dirt, stones, debris, and voids to ensure a watertight seal. Place a flexible gasket joint material, minimum 1/2-inch-thick, in two concentric rings along the inside and outside edge of each joint. Position the butt joint for each length of joint material on opposite sides of the manhole. No steel shims, wood, stones, or any material not specifically accepted by the Engineer may be used to obtain final surface elevation of the manhole frame.

When precast concrete grade adjustment rings are placed on the manhole structure to obtain proper grade, no more than 24 vertical inches may be used, unless approved by the Engineer.

Seal the rubber manhole adjusting ring to the precast concrete adjusting ring and the manhole frame as shown on the drawings.

In paved areas or future paved areas, castings shall be installed by using a straight edge not less than ten (10) feet long so that the top of casting will conform to the slope and finish elevation of the paved surface. The top of the casting shall be 1/8 inch below the finished elevation. Allowances for the compression of the joint material shall be made to assure a proper final grade elevation.

Manhole rims in parkways, lawns and other improved lands shall be at an elevation not more than one (1) nor less than one-half (1/2) inch above the surrounding ground. Backfill shall provide a uniform slope from the top of manhole casting for not less than three (3) feet each direction to existing finish grade of the ground. The grade of all surfaces shall be checked for proper slope and grade by string lining the entire area re-graded near the manhole.

Manholes in open fields, unimproved land, or drainage courses shall be set as required by the Engineer.

On non-paved manholes, exterior surfaces of all exposed grade adjustments and four inches below sound structure shall be cleaned with a wire brush and then waterproofed with trowelable bitumastic gasket material in accordance with the manufacturer's specifications. A protective polyethylene cover shall be placed over

the waterproofing material when backfilling, following sealing of the frame and grade adjustment.

7. INSPECTION AND APPROVAL

Test manholes in accordance with Section D1-7 – Manhole Testing.

Do not begin backfilling until pipeline installation is accepted in writing by the Engineer.

8. MANHOLE FRAMES AND COVERS

Install only frames and covers of iron material, unhinged, in streets and traffic areas.

Manhole frames and covers in grass easement areas may be of iron material, unhinged covers.

Watertight covers shall be used on all manholes in areas subject to flooding.

D. Measurement and Payment

1. METHOD OF MEASUREMENT

Manhole measurement will be of each standard or drop inlet manhole accepted according to the depth classes shown. Depth measurement will be the vertical distance from the rim elevation to the centerline invert.

2. BASIS OF PAYMENT

Manholes shall be paid for each type manhole installed, by diameter of manhole for the specified depth in the bid form. Price shall be unit price per each which includes all labor, material, and equipment required to install manhole, drop inlet for drop manholes, frame, cover, base, extension rings, couplings, connectors, excavation, backfill, coatings, watertight inserts, and connections to manhole according to these specifications and as shown on the construction Drawings or identified in the field. Payment will be made only after the manhole passes applicable tests. Both vacuum tests and dye tests are required on all manholes.

No differentiation will be made for extra depth between standard or drop manholes, or for type of ring and cover.

END OF SECTION D2-6

D2-9 EXCAVATION

A. General

1. Excavation work shall be accomplished under the supervision of a person experienced with the materials and procedures which will provide protection to existing improvements, including utilities and the proposed pipeline.
2. The alignment, depth, and pipe subgrades of all sewer trenches may be determined by overhead grade lines parallel to the sewer invert, or by the use of a laser.
3. In the event hazardous wastes as defined by the Resource Conservation and Recovery Act of 1976 (PL94-580) are encountered work shall be halted and the Owner shall be notified. Work shall be resumed only after the Owner notifies the Contractor.
4. If the specified maximum trench widths are exceeded, either through accident or otherwise, and if the Engineer determines that the design loadings of the pipe will be exceeded, the Contractor will be required to support the pipe with an improved trench bottom. The expense of such remedial measures shall be entirely the Contractor's own. All trenching operations shall be confined to the width of permanent rights-of-way, permanent easements, and any temporary construction easements. All excavation shall be in strict compliance with the Trench Safety System (D1-10) of this document.
5. Definitions
 - a. Excavation

Excavation is the removal of all material from the trench area. Included in excavation is the removal of existing paved surfaces including but not limited to concrete curb and gutter, PCC pavement, and bituminous pavement.

B. Materials

Not specified.

C. Execution

1. Open Cut Method (Trenching)
 - a. General

Open cut (trench) pipeline excavations except as otherwise specified or approved by the Engineer. Minimize inconvenience and disturbance to the general public.

Sort and stockpile the excavated material so the proper material is available for backfill.

b. Trench Depths

Excavate trenches to depths required for proper pipe embedment. Overdepth excavation may be required when the subgrade is unstable. Backfill overdepth excavations with granular pipe embedment material, unless otherwise directed by the Engineer.

c. Trench Walls

Undercutting of trench walls is not permitted.

d. Trench Widths

- 1) The bottom width of the trench at and below the top of the pipe and inside the sheeting and bracing, if used, shall not exceed the trench widths indicated on the Drawings.
- 2) If the allowable maximum widths are exceeded at manholes, bore pits, tees, and in unstable earth material, provide bedding adequate to develop the required lateral support for the pipe and/or provide a sufficient strength class of pipe to accommodate the loading conditions as approved by the Engineer.

e. Trench Safety

Trench safety shall be in accordance with Section D1-10.

f. De-Watering

- 1) Should groundwater be encountered, Contractor shall be responsible for utilizing a dewatering system(s) to remove water from the excavations. Contractor shall install and operate dewatering system(s) to achieve the following:
 - a) Keep excavations free from water.
 - b) Prevent displacement of surrounding soils.
 - c) Prevent water from crossing road or driveways during icing conditions or other potentially hazardous conditions.
- 2) Form dams, flumes or other works necessary to keep the trenches clear of water while the sewers and their foundations, and other foundation works, are being constructed. Remove water from such excavation in a manner that does not damage property.

- 3) Repair pit excavations shall be kept free of water and sewage during sewer pipe replacements through final inspection. Plug lines upstream and if necessary, provide bypass pumps of sufficient capacity to reroute water and sewage to a downstream manhole until pipe replacements have been completed and bedding material has been effectively placed and compacted. No bypassed wastewater from the sanitary sewer shall be allowed to discharge to natural or manmade surface drainage. Where plugging only is used for flow control, the Contractor shall monitor upstream manholes and prevent excessive surcharge conditions. Flow bypassing equipment shall be set up for immediate use and available on site in all stages of construction.

g. Unsuitable Soil

When unsuitable soil conditions are encountered under sewers below the depth of standard bedding, replace the unsuitable material with trench foundation material of gradation approved by the Engineer.

h. Blasting Areas

- 1) Blasting of any kind for rock excavation or any other purpose will not be allowed unless approved by the Engineer.
- 2) When blasting is permitted by the Engineer the Contractor shall use the utmost care to protect life and property. The Contractor shall comply with all laws, ordinances, and the applicable safety code requirements and regulations relative to the handling, storage and use of explosives and protection of life and property, and he shall be responsible for all damage thereto caused by his or his subcontractor's operations.
- 3) Contractor shall provide insurance as required by the Owner before performing any blasting. The governing agency shall be notified at least 24 hours before blasting operations begin.

D. Measurement and Payment

Only items listed below will be measured for payment. All other costs shall be included in the unit or lump sum prices for the item affected thereby.

1. Trench safety system shall be paid for in accordance with Section D1-10.

END OF SECTION D2-9

D2-10 BACKFILL

A. General

1. This section governs all labor, equipment, materials and testing required to properly backfill trenches and excavations around manholes and structures.
2. No granular embedment or other backfill material may be used by the Contractor without approval by the Engineer.

B. Materials

1. Trench Foundations Materials: Three-inch minus river-run or pit-run gravel, free from clay balls, roots, and organic matter; well crushed gravel or crushed rock graded with less than 8 percent by weight passing the 1/4-inch sieve. Submit samples for approval prior to delivery of the material to the site. Trench foundation material shall only be used where unsuitable soil conditions are encountered under sewers before the depth of standard embedment as defined in Section D2-9.
2. Embedment:
 - a. Embedment material shall be crushed rock free from dirt, clay balls, and organic material.
 - b. Embedment material shall be placed per the provided details.
3. Trench Backfill: Trench backfill will be divided into the general classification as follows:
 - a. Street Backfill: See D2-10(3) 2.
 - b. Trench Backfill: Backfill for trenches in unpaved areas shall meet the following requirements:
 - (1) Excavated material free from roots, organic matter, trash, debris, rocks larger than one inch, and other deleterious materials. Suitable material may be obtained by the Contractor from the excavation for the proposed pipelines. Provide imported material of equivalent quality, if required to accomplish the work.

C. Description

1. The Contractor shall be responsible for the furnishing of all labor, supervision, materials, equipment and testing for the completion of backfill operations in accordance with the Contract Documents.
 - a. Unless otherwise specified, all sewer trenches and excavation around structures shall be backfilled to the original surface of the ground.
 - b. The Contractor shall be responsible for all damage or damages which might occur as a result of the settlement of trench or other backfill made by him in the fulfillment of these Contract Documents, within and during a period of two (2) years from and after the date of final acceptance thereof by the Owner, including the cost to the owner of all claims of damages filed with and court actions brought against the said Owner for and because of such damage, and the repair to the satisfaction of the Owner of any and each pavement, driveway, curb, slab, walk, or structure damages by such backfill settlement.
2. "Pavement Areas" shall be defined as all streets, paved alleys, parking areas, driveways, curbs and gutters, and sidewalks.

D. Execution

1. General
 - a. Remove trash and debris from the excavation prior to backfilling.
 - b. Backfilling trenches and excavations to the original ground surface unless otherwise indicated on the Drawings.
 - c. Carefully place backfill materials to avoid damage to or displacement of the pipeline and other exposed utilities or structure.
 - d. Do not backfill with frozen material or when a blanket of snow prevents proper compaction. Backfill shall not contain waste material, trees, organic material, rubbish or other deleterious substances.
 - e. The backfill material shall be placed in six-inch (6") lifts. Each lift shall be compacted to the required density prior to the next lift being placed.
 - f. In gardens or flower gardens, the original topsoil shall be replaced to original elevation, location, and depth. Minimum depth shall be twelve (12) inches.
2. Backfilling in Street Right-of-Way and Pavement Areas

a. Backfill trenches under all existing and proposed pavement, driveway pavement, sidewalk, and curb and gutter using flowable backfill. Flowable backfill shall consist of a mixture of native soils or manufactured materials, cement, and/or fly ash, and water which produces a material with unconfined compressive strength of between 250 and 450 psi after 28 days. The flowable mixture shall be mixed in a pug mill, concrete mixer, or transit mixer and shall have a minimum slump of 5 in. The flowable mixture must be allowed to set prior to the placement of any overlying material.

b. Compaction Method

Granular trench backfill shall be mechanically compacted in layers of six inches (6") loose measure. Each layer shall be firmly compacted to 95 percent of density as determined by Standard Proctor Test. Material may be compacted by tamping or by using surface vibrators in such a manner as not to disturb or injure the pipe. At least 48 inches of cover over sewer pipe shall be provided before using mobile trench compactors of the hydrohammer or impactor type.

c. Undermining of Paved Surfaces

Where undermining of paved surfaces has occurred, Contractor shall remove the paved surface above the undermined area prior to placing backfill.

3. Backfilling in Areas Other Than Street Right-of-Way and Pavement Areas

a. Backfill trenches using acceptable job excavated materials or as directed by the Engineer.

b. Backfill in layers of six inches (6") maximum and mechanically compact to 95 percent of density as determined by Standard Proctor Test.

c. Place a minimum of six inches (6") of granular backfill above the top of pipe in areas where the existing surface elevation is less than 24 inches above the proposed top of pipe. The granular backfill shall extend one foot from each side of the pipe and shall be placed at a 1:1 slope to bedding material or the existing ground surface.

4. Testing

All density tests shall be performed per A.S.T.M. standards by an independent testing laboratory whose qualifications have been reviewed by the Engineer.

a. Tests shall be performed at two (2) feet vertical intervals beginning at a level two (2) feet above the top of all installed pipes and continuing to the top of the completed backfill, to assure a minimum density of 95 percent Proctor. The Contractor is responsible for the cost of the testing. Test reports shall be furnished to the Engineer upon completion of testing, as part of the qualification for acceptance of the installed manhole. The Engineer expects to perform unannounced spot checks of the compaction tests for verification and control purposes. These spot checks will be performed by Engineer at Owner expense and will not be charged to the Contractor.

However, the Contractor will be responsible for providing access and trench safety system to the level of trench backfill to be tested. No extra compensation will be allowed for exposing the backfill layer to be tested or providing trench safety system for tests conducted by the Engineer.

- b. The cost of providing access to the level of trench backfill to be tested will be a cost to the Contractor, and no extra compensation will be allowed for exposing of the backfill layer to be spot tested by the Owner.
 - c. Test results not conforming to specified densities shall be paid for by the Contractor at no additional cost to the Owner.
 - d. Density tests are not required on trenches that are backfilled with flowable backfill.
5. Responsibility of Contractor for Backfill Settlement

Wherever trenches or other excavations made by the Contractor in the performance of work under these Contract Documents have not been properly filled, or where settlement has occurred at any time prior to the completion of the entire work covered by these Contract Documents, to the extent that the top of the backfill is below the original ground surface, such trenches shall be refilled and backfill surface compacted and smoothed to conform to the elevation of the adjacent ground surface. All sod in lawns damaged by reasons of such settlement, and the repair thereof, shall be replaced.

E. Measurement and Payment

- 1. Payment for the work in this Section shall not be paid for separately but shall be included in the unit price bid for all work items affected thereby.

END OF SECTION D2-10

D2-11 ABANDONMENT OF SANITARY SEWERS

PART 1: GENERAL

1.01 SECTION INCLUDES

A. Abandonment in place, by cutting and capping, of existing sewers, junction structures, manholes, service lines, and force mains.

B. Abandonment in place of existing sewers and force mains using flowable fill. Flowable fill will be utilized when abandoning existing sewers and force mains underneath roadways and paved areas and at the direction of Engineer as field conditions dictate, or as specified on the Drawings.

1.02 SUBMITTALS

A. Conform to requirements of Section D1-3 Submittals.

B. Submit product data for proposed plugs for approval.

C. Technical information for equipment and operational procedures including projected slurry injection rate, grout pressure, method of controlling grout pressure, bulkhead and vent design, and number of stages of grout application.

D. At least 15 days prior to commencing abandonment activities, submit plan for abandonment, describing proposed grouting sequence, bypass pumping requirements and plugging, if any, and other information pertinent to completion of work.

PART 2: PRODUCTS

2.01 PLUGS

A. Grout Plugs: Cement-based dry-pack grout conforming to ASTM C1107, Grade B or C.

B. Manufactured Plug: Commercially available plug or cap specifically designed and manufactured to be used with pipe being abandoned.

2.02 FLOWABLE FILL REQUIREMENTS

A. Unconfined compressive strength: minimum 75 psi and maximum 150 psi at 56 days as determined based on an average of three tests for same placement. Present at least three acceptable strength tests for proposed mix design in mix design report.

B. Placement characteristics: self-leveling.

C. Shrinkage characteristics: non-shrink.

D. Water bleeding for fill to be placed by grouting method in sewers: not to exceed 2 percent according to ASTM C940.

E. Minimum wet density: 90 pounds per cubic foot.

2.03 BALLAST

A. Ballast Material: Natural rock or concrete pieces with minimum size equal to at least 10 times maximum aggregate size of flowable fill and maximum size of 24 inches. Maximum dimension shall not be more than 20 percent of minimum dimension of space to be filled.

B. Ballast Composition: Free of regulated waste material.

PART 3: EXECUTION

3.01 DEMOLITION OF SEWER MANHOLES, PIPELINE STRUCTURES, AND FORCE MAINS PRIOR TO ABANDONMENT

A. Remove manhole frames and covers and castings from other existing pipeline structures. Deliver castings to disposal facility as directed by Owner or Engineer.

B. Demolish and remove precast concrete adjustment rings and corbel section, or brick and mortar corbel and chimney, or other pipeline structures, to minimum depth of 4 feet below finished grade. Structure may be removed to greater depth, but not deeper than 18 inches above crown of abandoned sewer.

C. Drain manholes and poke holes in manhole floors and walls prior to filling.

D. When adjacent sewer lines are not to be filled, place temporary plugs in each line connecting to manhole, in preparation for filling manhole.

E. Excavate overburden from force mains to be abandoned at locations indicated on Drawings, conforming to the specification section for Excavation and Backfill for Utilities. Cut existing force main, when necessary, to provide an end surface perpendicular to axis of pipe and suitable for plug to be installed. Remove force main piping material remaining outside of segment to be abandoned.

3.02 CUTTING AND CAPPING OF MAINS

A. Do not begin cut, plug, and abandonment operations until replacement sewer or force main, has been constructed and tested, all service connections have been installed, and main has been approved for use.

B. Install plug, clamp, and concrete reaction block and make cut at location shown on Drawings and/or as directed by Engineer.

C. Main to be abandoned shall not be valved off and shall not be cut or plugged other than as shown on Drawings.

D. After main to be abandoned has been cut and capped, check for other sources feeding abandoned sewer main. When sources are found, notify Owner or Engineer immediately. Cut and cap abandoned main at point of other feed as directed by Engineer.

E. Plug or cap ends or opening in abandoned main in manner approved by Engineer. Install concrete around cap and over pipe to ensure it is not penetrable by groundwater.

F. Remove and dispose of surface identifications such as cleanouts. Clean-outs in improved streets, shall be filled with concrete.

G. Backfill excavations in accordance with Section D2-10.

H. Repair street surfaces in accordance with local and IDOT regulations.

I. Mark location of abandoned sewer laterals on Drawings and provide to Engineer.

3.03 CUTTING AND CAPPING OF SERVICES

- A. Do not begin cut, plug, and abandonment operations until replacement service, if necessary, has been constructed and tested, and all service connections have been installed.
- B. Service lines shall be cut and capped at the sewer main and/or as directed by Engineer.
- C. Before backfilling of a capped service line is started, the capping must be observed by Engineer.
- D. After service to be abandoned has been cut and capped, check for any other sources feeding abandoned sewer service. When sources are found, notify Owner or Engineer immediately. Cut and cap abandoned main at point of other feed as directed by Engineer.
- E. Plug or cap ends or opening in abandoned service in manner approved by Engineer. Install concrete around cap and over pipe to ensure it is not penetrable by groundwater.
- F. Remove and dispose of surface identifications such as cleanouts. Cleanouts in improved streets, shall be filled with concrete.
- G. Backfill excavations in accordance with Section D2-10.
- H. Repair paved surfaces in accordance with local and IDOT regulations.
- I. Mark location of abandoned sewer laterals on Drawings and provide to Engineer.

3.04 ABANDONMENT OF FORCE MAINS

- A. Do not begin cut, plug, and abandonment operations until replacement force main has been constructed and tested, and all service connections have been installed.
- B. Install plug, clamp, and concrete reaction block and make cut at location shown on Drawings.
- C. Main to be abandoned shall not be valved off and shall not be cut or plugged other than as shown on Drawings.
- D. After force main to be abandoned has been cut and plugged, check for other sources feeding abandoned force main. When sources are found, notify Owner or Engineer immediately. Cut and plug abandoned force main at point of other feed as directed by Engineer.
- E. Plug or cap ends or openings in abandoned force main in manner approved by Engineer.
- F. Remove surface identifications and appurtenances such as valve boxes.
- G. Backfill excavations in accordance with Section D2-10
- H. Repair street surfaces in accordance with local and IDOT regulations.

3.05 PREPARATION FOR ABANDONMENT VIA FLOWABLE FILL

- A. Have fill mix design reports and other submittals Section D1-3 accepted by Engineer prior to start of placement. Notify Engineer at least 24 hours in advance of grouting with flowable fill.

B. Select fill placement equipment and follow procedures with sufficient safety and care to avoid damage to existing underground utilities and structures. Operate equipment at pressure that will not distort or imperil portion of work, new or existing.

C. Clean sewer lines and video with closed circuit television to identify connections, locate obstructions, and assess condition of pipe. Locate previously unidentified connections, which have not been redirected and reconnected as part of this project, and report them to Engineer. During placement of fill, compensate for irregularities in sewer pipe, such as obstructions, open joints, or broken pipe to ensure no voids remain unfilled.

D. Perform demolition work prior to starting fill placement. Clean placement areas of sewers and manholes of debris that may hinder fill placement. Remove excessive amounts of sludge and other substances that may degrade performance of fill. Do not leave sludge or other debris in place if filling more than 2 percent of placement volume.

E. Remove free water prior to starting fill placement.

3.06 EQUIPMENT FOR FLOWABLE FILL

A. Mix flowable fill in automated batch plant and deliver it to site in ready-mix trucks. Performance additives may be added at placement site if required by mix design.

B. Use concrete or grout pumps capable of continuous delivery at planned placement rate.

3.07 INSTALLATION OF FLOWABLE FILL

A. Abandon existing sewer lines and force mains underneath roadways and paved areas by completely filling sewer line with flowable fill. Abandon manholes and other structures by filling with flowable fill, together with ballast as applicable, within depth of structures left in place.

B. Place flowable fill to fill volume between manholes. Continuously place flowable fill from manhole to manhole with no intermediate pour points, but not exceeding 500 feet in length.

C. Have filling operation performed by experienced crews with equipment to monitor density of flowable fill and to control pressure.

D. Temporarily plug sewer lines which are to remain in operation during pouring/pumping to keep lines free of flowable fill.

E. Pump flowable fill through bulkheads constructed for placement of two 2-inch PVC pipes or use other suitable construction methods to contain flowable fill in lines to be abandoned. These pipes will act as injection points or vents for placement of flowable fill.

F. Place flowable fill under pressure flow conditions into properly vented open system until flowable fill emerges from vent pipes. Pump flowable fill with sufficient pressure to overcome friction and to fill sewer from downstream end, to discharge at upstream end.

G. Inject flowable fill through replaced ballast using grouting equipment and series of grout pipes discharging at bottom of placement, allowing fill to rise through ballast effectively filling all voids. Alternatively, sequentially place individual pieces of ballast at same time as flowable fill is placed. Do not fill with ballast more than 50 percent of volume at any level, to prevent nesting and void formation.

H. Remediate placement of flowable fill which does not fill voids in sewer, in force main, and in manhole or other structures, or where voids develop due to excessive shrinkage or bleeding of fill, by using pressure grouting either from inside sewer or from surface.

I. Plug each end of force main being abandoned, if not filled with flowable fill.

I. Clean inside surface of force main at least 12 inches from ends to achieve firm bond and seal grout plug or manufactured plug to pipe surface. Similarly, clean and prepare exterior pipe surface if manufactured cap is to be used.

K. When using grout plug, place temporary plug or bulkhead approximately 12 inches inside pipe. Fill pipe end completely with dry-pack grout mixture.

L. When using manufactured plug or cap, install fitting as recommended by manufacturer's instructions, to form watertight seal.

M. Backfill to surface, above pipe or structures left in place, with flowable fill in restricted areas, compacted bank run sand in unrestricted areas to be paved or select fill in unrestricted areas outside of pavement. Place and compact backfill, other than flowable fill, in compliance with Section D2-10 - Backfill.

N. Collect and dispose of excess flowable fill material and other debris in accordance with local requirements or as directed by Owner or Engineer.

3.08 PROTECTION OF PERSONS AND PROPERTY

A. Provide safe working conditions as required by OSHA and applicable State and local laws for employees throughout demolition and removal operations. Observe safety requirements for work below grade.

B. Maintain safe access to adjacent property and buildings. Do not obstruct roadways, sidewalks, or passageways adjacent to Work.

3.09 MEASUREMENT AND PAYMENT

A. Payment for the grout fill and abandonment of existing sanitary sewers will be incidental to the work item as indicated on the bid form.

B. Payment for the grout fill and abandonment of sanitary sewer manholes will be incidental to the work item as indicated on the bid form.

END OF SECTION D2-11

D2-12 CURED-IN-PLACE PIPE (CIPP)

A. General

1. Description

The Contractor shall utilize the installation of flexible sewer pipe (CIPP) in accordance with ASTM F1216 to restore the watertight condition of sanitary sewer lines which would otherwise require various point repairs and/or removal of cross connections. Due to existing alignment conditions in the sewers to be lined, only products meeting ASTM F1216 (Installation by Inversion Method) will be accepted.

B. Materials

1. Cured-in-Place Material (CIPP)

The flexible tube material shall be a polyester fiber felt tubing lined on one side with polyurethane and fully impregnated with a liquid, thermosetting resin as specified. The polyester felt tubing, including the polyurethane coated felt and the thermosetting resin shall meet manufacturer's standards. The cured pipe shall be a hard impermeable pipe which shall conform to the minimum structural standards applicable including ASTM D-638 for 3,000 psi tensile stress, ASTM D-790 for 4,500 psi for flexural stress, and ASTM D-790 for 400,000 psi for modules of elasticity. The finished liner shall incorporate thermosetting materials which will withstand the corrosive effects of normal sewage. The Contractor shall provide a written guarantee of his compliance with these standards.

The tube material shall meet the requirements of ASTM F1216, Section 5.1. The resin system shall meet the requirement of ASTM F1216. The chemical resistance requirements shall conform to ASTM F1216, Appendix 2.

2. Sizing of the CIPP

The CIPP diameter, length and wall thickness shall be appropriate for each designated location. The Contractor shall verify the actual sewer lengths and diameters in the field prior to cutting the tube to length and sizing the diameter. The Contractor shall verify the proposed CIPP lining thicknesses and submit the associated calculations. The CIPP lining for 8-inch host pipe shall be designed in accordance with the applicable ASTM F1216 provisions for "fully deteriorated gravity pipe conditions." The CIPP lining for other pipe sizes may be designed in accordance with the applicable ASTM F1216 provisions for "partially deteriorated gravity pipe conditions," unless the Engineer has indicated on the Drawings that "fully deteriorated gravity pipe conditions" shall apply based on reviewing the CCTV video. The CIPP lining shall meet the following minimum design conditions, unless the Engineer agrees to their change or as noted on the Drawings:

- a. The tube shall be fabricated to a size that when installed will neatly fit the internal circumference of the sewer designated for CIPP. Allowance for circumferential

stretching during insertion shall be made as per manufacturer's standards.

- b. The length of the CIPP shall be that deemed necessary by the Contractor to effectively carry out the insertion and seal at the inlet and outlet points. When cured, the CIPP should extend from end to end of the sewer segment being lined in a continuous tight-fitting watertight pipe-within-a-pipe.
- c. AASHTO H-20 Live Load with two trucks passing
- d. Soil elasticity modulus = 1,000 psi
- e. Soil weight with 120 pounds per cubic foot and a coefficient of friction of $Ku' = 0.130r$ shall be used for the installed depths.
- f. The long-term flexural modulus used in the design calculations shall be estimated by multiplying the lowest short-term flexural modulus specified in the ASTM standards by a 0.50 retention factor.
- g. Design safety factor = 2.0
- h. Typical groundwater levels shall be estimated at 1/2 the distance between the pipe's invert and the ground surface. If actual groundwater depth information is available from USGS or other sources, it may be used in the calculations. If the sewer is within 50 feet of a creek or other water body or if indicated on the Drawings, the groundwater depth used in the calculations should be the maximum depth from the ground surface to the pipe crown.
- i. Service temperature range shall be 40 to 100 degrees F.
- j. Maximum long-term deflection shall be 5 percent.
- k. Minimum pipe ovality shall be 2 percent.
- l. The CIPP lining thickness to be used shall be the largest thickness as determined by calculations for deflection, bending, buckling, and minimum stiffness.
- m. The minimum lining thickness following installation and curing shall be as follows:

Pipe Diameter	Depth of Sewer to Invert (ft)	Minimum Thickness (mm)
8-inch	0 to 20	6.0
10-inch	0 to 20	6.0
12-inch	0 to 12	6.0
12-inch	12.01 to 20	7.5
15-inch	0 to 12	7.5
15-inch	12.01 to 20	9.0
18-inch	0 to 8	7.5
18-inch	8.01 to 12	9.0

18-inch	12.01 to 16	10.5
18-inch	16.01 to 20	12.0

C. Execution

1. General

CIPP installation shall be accomplished by inverting the resin impregnated tube into the existing sanitary sewer pipeline utilizing an inversion standpipe and hydrostatic head. Curing of the CIPP shall be accomplished by circulating hot water/steam to cure the thermosetting resin into a hard-impermeable pipe.

2. Preliminary Cleaning and Inspection

- a. Prior to CIPP installation of designated sanitary sewer line segments the Contractor shall remove internal deposits as necessary to assure proper liner installation.
- b. Inspection of pipelines shall be performed by experienced personnel trained in locating breaks, obstacles, and service connections by closed circuit television. The interior of the pipeline shall be carefully inspected to determine the location and extent of any structural failures, which may prevent proper installation of lining materials into the pipelines and location of service laterals.
- c. It shall be the responsibility of the Contractor to clear the line of obstructions such as solids, roots, dropped joints, protruding branch connections or broken pipe that will prevent the insertion of the liner. If inspection reveals an obstruction not indicated in these specifications that cannot be removed by conventional cleaning equipment then the Contractor shall notify the Engineer. The Engineer may authorize an excavation in order to remove such obstruction.

3. Documentation

DVD and a suitable log shall be provided by the Contractor which shall document, to the satisfaction of the Engineer, the condition of the sewer line segment both immediately before and after lining has been installed. The DVD and log shall become the property of the Owner. The Contractor shall review the existing condition of the line and justify to the satisfaction of the Engineer any and all point repairs prior to any construction.

4. Flow Bypassing

The Contractor, when required, shall provide for the transfer of flow around the section or sections of pipe that are to be lined. The bypass shall be made by diversion of the flow at an existing upstream access point and pumping the flow into a downstream access point or adjacent system. The pump and bypass lines shall be of adequate capacity and size to handle the flow. The proposed bypassing system shall be approved in advance by the Owner.

5. Notification of the Public

The Contractor shall notify all property owners affected by the CIPP installation work at least 48 hours prior to commencement of the work which will temporarily plug the sanitary services of the property owners connected to the sewer line segment being lined.

6. CIPP Installation

- a. The Contractor shall designate a location where the uncured resin in the original containers and the unimpregnated liner will be vacuum impregnated prior to installation. The Contractor shall allow the Owner to inspect the material and “wet out” procedure. A resin and catalyst compatible with the requirement of this method shall be used. The quantities of the liquid thermosetting materials shall be in accordance with the manufacturer's standards to provide the lining thickness specified.
- b. The wet out tube shall be inserted through an existing manhole or other approved access by means of an inversion process and the application of a hydrostatic head sufficient to fully extend the lining to the next designated access point. The impregnated tube shall be inserted into the inversion standpipe with the impermeable plastic membrane side out. At the lower end of the inversion standpipe, the tube shall be turned inside out and attached to the inversion standpipe so that a leak proof seal is created. The inversion head will be adjusted to be of sufficient height to invert the liner to the next access point designated and to hold the liner snug to pipe wall and to produce dimples at side connections and flared ends at the entrance and exit access points. The use of a lubricant is recommended and if used such lubricant shall be approved by manufacturer's standards. The manufacturer's standards shall be closely followed during the elevated temperature process curing so as not to over stress the felt fiber and cause damage or failure of the liner prior to cure. In certain cases, the Contractor may elect to use a Top Inversion. In this method the tube is pre-inverted to a distance that corresponds to the minimum inversion head and instead of attaching to an elbow at the base of the inversion tube, the liner is attached to a top ring.
- c. After inversion is completed the Contractor shall supply a suitable heat source and water recirculation equipment. The equipment shall be capable of delivering hot water to the far end of the liner through a hose, which has been perforated per manufacturer's recommendations, to uniformly raise the water temperature in the entire liner above the temperature required to effect a cure of the resin. This temperature shall be determined by the resin/catalyst system employed. The heat source shall be fitted with suitable monitors to gauge the temperature of the incoming and outgoing heat exchanger circulating water. Thermocouples shall be placed between the tube and the invert at near and far access to determine the temperature of the tube and time of exotherm. Water temperature in the line during the cure period shall not be less than 150°F as measured at the heat exchanger return line. Initial cure shall be deemed to be completed when inspection of the exposed portions of the liner appear to be hard and sound and the thermocouples indicate that an exotherm has occurred. The cure period shall be of a duration recommended by the resin manufacturer, as modified for the Insituform

process, during which time the recirculation of the water and cycling of the heat exchanger to maintain the temperature in the tube shall be continuous.

- d. The Contractor shall cool the hardened CIPP to a temperature below 100°F before relieving the static head in the inversion standpipe. Cool-down may be accomplished by the introduction of cool water into the inversion tube to replace water being drained from a small hole made in the end of the CIPP at the downstream end. Care shall be taken in the release of the static head such that a vacuum will not be developed that could damage the newly installed CIPP.
- e. The finished CIPP shall be continuous over the entire length of an insertion run and be as free from visual defects such as foreign inclusions, dry spots, pinholes, and delamination. The CIPP shall be impervious and free of any leakage from the pipe to the surrounding ground or from the ground to the inside of the CIPP. Any defects which will affect, in the foreseeable future, or warranty period, the integrity or strength of the CIPP, shall be repaired at the Contractor's expense, in a manner mutually agreed by the Owner and the Contractor.

7. Completion of CIPP

- a. If due to broken or misaligned pipe at the access point, the CIPP fails to make a tight seal, the Contractor shall apply a seal at that point. The seals shall be of a resin mixture compatible with the CIPP.
- b. After the CIPP has been cured, the Contractor shall reconnect the existing active service connections. Reconnection of service connections shall be accomplished per specification D2-14 Service Connection Repair and SP4. Any bypass pumping that is required shall be provided at no additional cost for sewer lines where lining is being performed. **Service interruptions to any homes tributary to this sewer line shall not exceed 18 hours.**
- c. The watertightness of the CIPP shall be gauged while the tube is curing, and under a positive head. After the work is completed, the Contractor will provide the Owner with a video tape showing both the before and after CIPP conditions including the restored connections. Upon completion of the installation work after required testing indicates the CIPP is acceptable, the Contractor shall reinstate the project area affected by his operation and perform any surface restoration in accordance with these Specifications.

8. Manhole Connections

All cracked or deteriorated material shall be removed from the area to be sealed. Thoroughly plug the annular space between the liner and the host pipe with resin used to impregnate the liner. Finish grout smooth and flush with the interior manhole wall surface and make watertight with non-shrink grout.

9. Testing Repaired Sanitary Sewer Lines

Testing of sanitary sewer lines for watertightness following installation of CIPP shall be televised and dyed water flooded as directed by the Engineer as specified in Section D1-8.

D. Measurement and Payment

1. CIPP

Payment shall be made at the Contract Unit Price per linear feet as indicated on the Bid Schedule for each individual job number. The price shall be payment in full for providing all materials, labor and equipment to install the lining system, excavation, backfill, surface restoration, temporary surface restoration, testing, final surface and internal television inspection before and after CIPP.

2. Manhole Connections

No contract prices are established for connections at manholes but shall be considered subsidiary to the cost of the CIPP.

3. Unit price for CIPP shall be eligible for 80 percent payment after repair is made. An additional 20 percent is eligible for payment after testing is complete.

E. Warranties

1. Contractor shall provide to Owner a one-year non-conditional warrantee on all work.

2. Warrantee period shall begin after final acceptance of work by owner.

END OF SECTION D2-12

D2-12A POST-REHABILITATION SANITARY SEWER CCTV INSPECTION

A. General

1. Description

The contractor shall perform all sewer line closed circuit television (CCTV) inspection work after the CIPP, rehabilitation or pipe replacement for the mainline and any lateral replacement or relining has been performed.

2. References

National Association of Sewer Service Companies (NASSCO):

- a. Pipeline Assessment and Certification Program (PACP) Reference Manual
- b. Recommended Specifications for Sewer Collection System Rehabilitation Standard (2006)

B. Definitions

1. Television Inspection: A necessary operation to complete a true-color audio-visual inspection to verify existing internal sewer line conditions. Furnish labor, materials, equipment, tools and other incidental services for CCTV inspection.
2. MPEG: MPEG is an acronym for Moving Pictures Expert Group, which is a family of international standards used for coding audio-visual information in a digital compressed format.
3. Digital Video Disk (DVD): For this section, DVD shall be written or “burned” in accordance with the ISO-9660 Level 2 Specifications. External hard drives for data transfer may be used and is preferred for data transfer.

C. Submittals

1. Submit a written/printed copy of television inspection logs to the Engineer. Logs shall record defects according to NASSCO’S Pipeline Assessment and Certification Program (PACP) or/and Manhole Assessment and Certification (MACP).
2. Submit two copies of visual and audio recording to the Engineer in electronic format. The Engineer will review the PACP database and inspections to ensure the required information is provided and the recording quality is acceptable, but not for content accuracy. If the Engineer determines the recording is defective or not adequate quality, the Contractor shall perform CCTV inspection again at the Contractor’s expense.

D. Quality Assurance

1. The television inspection shall be performed one section of line at a time. An individual digital video file and data file shall be developed for each manhole to manhole section.
2. Inspection shall be performed in accordance with NASSCO's Pipeline Assessment and Certification Program (PACP) and/or Manhole Assessment and Certification Program (MACP).

E. Television Inspection Equipment

1. The television inspection equipment shall be able to inspect 1,000 feet minimum sewer line when entry into the sewer can be accessed from the upstream and downstream manholes. When entry is at one end only, the inspection equipment shall be able to inspect 750 feet by a self-propelled unit. The inspection equipment shall be able to clearly televise the interior of 6-inch and larger diameter sewers.
2. Transport the television equipment in a stable condition through the sewer line to be inspected. Throughout the inspection, position the camera equipment with the camera directed along the sewer's longitudinal axis.

F. Television Camera

1. Use a television camera specifically designed and constructed for sewer pipeline inspection. The camera shall be waterproof and able to operate in any conditions encountered in the inspection environment. Provide a color pan, tilt, and zoom camera to facilitate inspecting service laterals and sewer line to clearly view manhole defects and construction features. The television camera shall be capable of 360-degree rotational scan indicating salient defects. The tilt arc shall not be less than 225 degrees unless otherwise approved by the Engineer. The focus and iris adjustment shall provide a minimum 3-inch focal range in front of the camera's lens.
2. The distance along the sewer in focus from the initial observation point shall be a minimum of twice the sewer's vertical height.
3. The illumination shall allow an even light shadowing distribution.
4. The view seen by the television camera shall be transmitted to an 11-inch or larger monitor. The television camera shall be able to receive and transmit a picture having not less than a 352(x) by 240(y) resolution. The television inspection camera travel speed through the sewer shall be uniform and shall not exceed 30 feet per minute maximum speed.
5. The television inspection equipment shall be a quality to achieve the following
6. The CCTV monitor display shall incorporate and automatically updated record in feet and tenths of a foot for the distance along the line from cable calibration point to the camera's or transducer's center point, whichever unit is being used. The relative positions for the two center points should also be noted. Use a metering device that enables the cable length to be accurately measured, this shall be accurate to 6-inches. Demonstrate

the tolerance is being achieved by tape measurement between manholes o the surface. This taped measurement must be included on each written and digital television log.

7. The CCTV camera shall be calibrated for accurate length measurements at least once per week with above ground markings every 25 feet for up to 100 feet. The accuracy should be within 0.2 foot for every 10 feet.
8. If the contractor fails to meet the required accuracy standard the Engineer will instruct the Contractor to provide a new device to measure the footage. The Engineer may instruct the Contractor to resurvey those sewer lengths first inspected with the original measuring device using the new measuring device.
9. Audio-visual recordings and collected data made during the television inspection shall become CITY OF MASCOUTAH property. Submit the digital data in CITY OF MASCOUTAH software format to the Engineer within two weeks from completing the television inspection.

G. Television

1. Inspect sewer pipelines with pan, tilt and zoom conventional television imagery to record relevant pipeline features and defects. Pipeline inspection shall be carried out in a format approved by the Engineer. Perform cleaning in accordance with contract document requirements.
2. CCTV operators shall be NASSCO PACP certified and have a current certification. Prior to beginning work, submit NASSCO's PACP certification for all CCTC operators performing this work on the project. Contractor shall not commence work until such certification is provided.
3. If television inspection for an entire section cannot be successfully performed from one manhole, perform a reverse setup to obtain a complete television inspection.
4. Perform sewer televising work as necessary to thoroughly document the condition for all sewers, service lateral connections, manhole corbel, barrel, and cone-sections in the study area. To achieve this, the CCTV camera operator shall stop the camera in each manhole invert, and shall pan and zoom up the manhole to obtain the best possible image of the manhole including the cone and corbel section(s).
5. The quality for all work specified in the section shall meet or exceed the National Association of Sewer Service Companies (NASSCO). Recommended Specifications for Sewer Collection System Rehabilitation (latest edition) requirements. Applicable Section portions which inadvertently fall below those standards shall be corrected and maintained at the NASSCO standards as a minimum requirement, at no additional cost to City.
6. Document all internal sewer inspections via digital video recordings, television logs, digital photos and a database compatible with the NASSCO PACP exchange database version 4.2 or newer if applicable. Acceptable media for the video recordings are digital video disc (DVD). DVD-RW+ is the preferred media. If the video is poor quality due to

the chosen media, Engineer reserves the right to require re-submittal on a different media. All media shall be previously unrecorded, premium grade. Create separate MPEG files for each sewer line segment. In a reverse setup, store such inspection in a separate MPEG file. MPEG files shall be written to DVD shall be labeled, at a minimum, with the following information: owner, engineering firm, project name, creation date, ID number, sewer line sections, and TV inspection contractor's firm name.

7. Digital video shall be defined as ISO-MPEG Level 1 (MPEG-1) coding with a 352-pixel (x) by 240-pixel (y) (minimum) resolution and a 30 frames per second encoded frame rate. The digital recording shall include audio and video information which accurately reproduced the original video inspection picture and sound. The digital recording's video portion shall be free from electrical interference, and shall produce a clear and stable image. The audio portion shall produce a clear and discernible oral report, sufficiently free from background and electrical noise.
8. Separate digital video recordings shall be made for each sewer section, and shall be properly identified via continuous on-screen display and voice-over recording with.
 - a. CITY OF MASCOUTAH Project number
 - b. Upstream MH ID and downstream MH ID
 - c. Sewer segment being inspected
 - d. Inspection date
 - e. Project name
 - f. Distance along the reach from the entering manhole.
9. Contractor shall coordinate with Engineer prior to commencing work to ensure identification is accomplished in a manner acceptable to CITY OF MASCOUTAH. If the video and/or audio recording is poor quality, the Engineer has the right to require a re-submittal of the affected sewer sections. No payment will be made until an acceptable video and audio recording is made, submitted to, and accepted.
10. Inspection software to be used shall be WinCan unless otherwise approved by the Engineer. If software other than WinCan is used, compile all video recordings, digital photos, and databases in WinCan software before submitting to the Engineer.
11. The CCTV inspection data via DVDs or external hard drive. Data shall be recorded and provided in a current version of the NASSCO PACP Exchange format. The data shall specifically include video indexing for all observations. Data to be submitted shall include.
 - a. NASSCO PACP exchanges database file
 - b. jpeg files (still photos)

- c. MPG-1 files (video) for each pipe segment.
12. Provide a complete television inspection for the upstream and downstream manholes. The CCTV operator shall pan and zoom up the manhole from the invert for each manhole and obtain the best possible image of the manhole including cone and corbel sections. In addition, 3 still digital photos shall be taken for each pipe connection within each manhole. The CCTV operator shall zoom in on each pipe connection so the photos capture each pipe connection's size, location, and approximate elevation.
13. Whenever prevailing conditions allow, position the camera head to reduce the risk of picture distortion. In circular sewers, position the camera lens centrally (i.e., in prime position) within the sewer. In noncircular sewer, picture orientation shall be taken at mid-height, unless otherwise agreed, and centered horizontally. Direct the camera lens along the sewer's longitudinal axis when in prime position. A $\pm 10^\circ$ positioning tolerance of the vertical sewer dimension shall be allowed when the camera is in prime position.
14. Perform the television inspections during low flow conditions. The Engineer will reject any television inspection that does not produce an effective sewer pipe survey due to flow conditions or for any other reason. Sewer flow shall be controlled so that the invert of rehabilitated pipe is fully visible.
15. Do not pull a cleaning device in front of the television inspection camera taping the sewer line.

H. Digital Audio/Visual Recording

1. Take continuous digital video recordings of the inspection view as it appears on the television monitor. A digital video recording shall be made for the complete television inspection of the sewer lines constructed as part of this project. The recording shall also be used as a permanent record for defects. The recording shall be MPEG file format. The digital video recording shall include sound and video information that can be reproduced with a video image equal or very close to the original picture quality on the television monitor. The recorded video information replay, when reviewed by Windows Media Player™, shall be free from electrical interference and shall produce clear, stable image. The composite digital coding's audio portion shall be sufficiently free from electrical interference/background noise to produce an oral report that is clear and completely and easily discernible.
2. The inspection report's audio portion shall include the section's location or identification the manhole-to-manhole travel direction, and the distance traveled on the specific run encountered. The inspection camera equipment shall be on the specific run encountered. Continuously connect the inspection camera equipment to the television inspection or monitoring equipment. The recording and monitoring equipment shall have the built-in capability to allow the Engineer to instantly review the recording's audio and video quality during the television survey. Playback speed shall be continuously adjustable from 1/3 normal speed for slow-motion viewing to normal playback speed.

3. Name the MPEG files according to the following file specification. Upstream Manhole Number Downstream Manhole Numner_Month_Day_Year.mpg.

I. Television Inspection Reports

1. Prepare a television inspection report covering the television inspection work and the information acquired. Prior to beginning work, submit a sample hardcopy television inspection report to the Engineer for review.
2. Report sewer defects in accordance with the National Association of Sewer Service Companies (NASSCO) program known as Pipeline Assessment and Certification Program (PACP). The Engineer reserves the right to refuse any inspection report that does not comply with PACP program.

J. Quality Control

1. Operate a quality control system that will effectively gauge the accuracy of inspection reports produced by the operators.
2. The Engineers shall be entitled to audit the control system and be present when sewer integrity assessments are being determined for rehabilitated or upgraded pipe. When requested provide sufficient details and information for such audit assessment. Should any report fail to achieve a margin the Engineer deems satisfactory, the Contractor, without any additional compensation, shall recode and resubmit any data reports.

END OF SECTION D2-12A

D2-13 SANITARY SEWER CONSTRUCTION

A. General

Sanitary Sewer Construction shall conform to “Standard Specifications for Water and Sewer Construction in Illinois”, Latest Edition

1. Scope

This Section governs all work, materials and testing required for installation of gravity pipelines of the respective types and sizes shown on the Drawings for the particular location and conforming to the requirements of these specifications. All pipelines shall be constructed to proper line and grade as shown on the Drawings and shall result in an unobstructed, smooth and uniform conduit.

2. Description

Sanitary sewer construction shall consist of furnishing all labor, materials and equipment for the complete installation of sewers and appurtenances in accordance with the Drawings.

3. Revisions of Standards

When reference is made to a Standard Specification i.e. ASTM, ANSI, AWWA, MCIB, the Specification referred to shall be understood to mean the latest revision of said specification as amended at the time of the Notice to Bidders, except as noted on the Drawings or in the Specifications.

B. Materials

1. General

This section governs materials required for pipeline construction.

a. Requirements

Furnish pipe of materials, joint types, sizes, and strength classes indicated and specified. Higher strengths may be furnished at the Contractor's option, at no additional cost to the Owner.

b. Manufacturer

The manufacturer shall be experienced in the design, manufacture and commercial supplying of the specific material.

c. Testing

Testing shall be performed by the manufacturer's quality control personnel in conformance with applicable standards. Testing may be witnessed by Owner, Engineer, or an independent testing laboratory. The Contractor shall provide three (3) copies of certified test reports indicating that material does conform to the specifications.

d. Handling

The manufacturer and contractor shall use equipment and methods adequate to protect the pipe, joint elements and prevent shock contact of adjacent unit during moving or storage. Contractor shall provide protection for all material from exposure to ultraviolet light. Damaged sections that cause reasonable doubt as to their structural strength or watertightness will be rejected.

2. Pipe, Fittings, Joints, Coatings and Linings

a. General

Furnish pipe and fittings of materials, joint types, sizes, strength classes, coatings and linings as indicated and specified.

Rubber couplings shall be as manufactured by Mission Rubber Co., Fernco, or equivalent. Rubber couplings shall be fastened using two type C-305 stainless steel adjustable clamps to provide a leakproof seal.

b. Ductile-iron pipe and fittings shall be Class 50 conforming to ANSI A21.51, except as otherwise specified herein.

1) General

Furnish maximum pipe lengths normally produced by the manufacturer, except for fittings, closures, and specials.

2) Joints

Mechanical and push-on joints for pipe and fittings shall conform to the requirements of ANSI A21.11. Flanged joints for ductile iron pipe and fittings shall conform to the requirements of ANSI A21.10. Gaskets shall be neoprene or other synthetic rubber material. Natural rubber gaskets will not be allowed.

3) Fittings

Fittings shall be in accordance with ANSI/AWWA C110/A21.10 and shall have a pressure rating of not less than that specified for the pipe. Fittings used with ductile iron pipe shall be ductile iron or cast iron. Fittings for pipe with mechanical joints shall have mechanical joints. Fittings for pipe with push-on joints shall have either mechanical joints or push-on joints.

4) Coatings

Where required pipe and fittings shall be furnished with exterior bituminous coating conforming to ANSI A21.51.

5) Linings

Pipe to be CIPP lined after installation.

- c. SDR 26 Polyvinyl Chloride (PVC) Plastic Sewer Pipe and Fittings shall conform to ASTM D3034 for pipes 6 inches through 15 inches in diameter. SDR 35 Polyvinyl Chloride (PVC) sewer pipe and fittings shall conform to ASTM F-679 for pipes 18 inches to 37 inches in diameter. Pipes 4 inches in diameter shall be Schedule 40 PVC to conform to ASTM D3034.

- 1) Furnish maximum pipe lengths normally produced by the manufacturer except for fittings, closures and specials.
- 2) The pipe shall be made of PVC plastic having a cell classification of 12454 B as defined in ASTM D1784. The resin portion of the copolymer compounds shall contain a minimum of 90 percent vinyl chloride and the compounding ingredients shall not exceed 10 percent by weight. The compounding ingredients may consist of lubricants, stabilizers, non poly (vinyl chloride) resin modifiers, and pigment essential for processing, property control, and coloring. Certification of resin compounding shall be provided by the pipe manufacturer prior to shipment to the job site.

One test to verify resin compounding may be required by the Owner or Engineer. The test shall be performed by an independent testing laboratory to which the Owner has no objection and shall be performed on a sample of pipe obtained from the job site. The test shall be performed at no additional cost to the Owner and shall be performed in accordance with ASTM D817 - Ash Determination for pipe manufactured with primarily noncombustible compounding ingredients.

- 3) Pipe shall have an integral wall bell and spigot joint and a minimum wall thickness conforming to SDR 26.
- 4) Joints shall conform to ASTM D 3212. Joints shall be push-on type only with the bell-end grooved to receive a gasket. Electrometric seal (gasket) shall have a basic polymer of synthetic rubber conforming to ASTM F477. Natural

rubber gaskets will not be allowed.

- 5) Fittings defined as tee or wye connections suitable for assembly to four (4) inch or six (6) inch building service lines shall be bell-end with a minimum wall thickness conforming to SDR 26 and shall be furnished by the pipe manufacturer.

d. Polyvinyl Chloride (PVC) Plastic Water Pipe

The pipe material shall be Polyvinyl Chloride (PVC) meeting the requirements of ASTM D1784, with a cell classification of 12454-B. The standard Dimensional Ratio for the pipe will be DR14 (Class 200) conforming to AWWA C900.

e. Non-Metallic Water and Sanitary Sewer Pipe Detection Tape

1. The detectable tape shall be "Detect Tape" as manufactured by Allen Systems, Inc. or approved equal, and shall consist of a minimum thickness 0.35 mils solid aluminum foil encased in a protective inert plastic jacket that is impervious to all known alkalis, acids, chemical reagents and solvents found in the soil. The minimum overall thickness of the tape shall be 5.5 mils and the width shall not be less than two (2) inches.
2. The tape shall be color coded and imprinted with the message as follows:

<u>Type of Utility</u>	<u>Color Code</u>	<u>Legends</u>
Water Safety Precaution	Blue	Caution Buried Water Line Below
Sewer Safety	Green	Caution Buried Sewer Line Below

f. Sewer Pipeline Markers

The sewer pipeline markers shall be Carsonite International Dual-Sided Utility Marker (CIB-380), or approved equal. All markers shall be installed according to the manufacturer's recommendations. The uppermost portion of the marker shall be made of Visibility Enhancer (CVE-360), or approved equal and must be bolted to the utility marker. The utility marker shall read as follows: "CAUTION, SEWER PIPELINE", "City of Mascoutah", The label shall also include the official City Logo and be green in color with white lettering.

Sewer line pipeline markers shall be installed beside all manholes that are located in easements and backyards. Those manholes located in front yards and in streets do not require markers. Concrete shall be placed 6-inches around and 1-foot deep around the base of each marker.

C. Installation

1. General

- a. Install pipelines in accordance with the applicable reference standard listed below and as specified herein.
 - 1) ASTM D2321 - PVC Solid Wall, PVC Composite Wall.
 - 2) AWWA C600 - Installation of Ductile Iron Water Mains and Appurtenances.
2. Site Preparation and Excavation
 - a. Site preparation shall be as specified in Section D2-1 – Site Preparation.
 - b. Excavation shall be as specified in Section D2-9 - Excavation.
 - c. All existing lines which are to be abandoned shall be internally inspected to identify locations of all existing service connections.
3. Pipe Embedment
 - a. Install a minimum of 6 inches of CA-7 grade material conforming to the requirements of Article 1004.01 of the “Standard Specifications for Road and Bridge Construction” prepared by the Illinois Department of Transportation for pipe bedding at all locations except where the pipe is encased in concrete.
 - b. Place pipe bedding below and on the sides of the pipe as indicated in the typical trench details on the Drawings.
 - c. Compact bedding and dig bell holes for bell and socket pipe so that the pipe is uniformly supported for its entire length and will be true to line and grade after installation.
 - d. After each pipe has been brought to grade, aligned, and placed in final position, extend the crushed limestone bedding to the pipe spring line. Shovel slice sufficient bedding material under the pipe haunches and on each side of the pipe to hold the pipe in proper position during subsequent pipe jointing, bedding, and backfilling operations. Crushed limestone embedment material shall then be added to a compacted depth of twelve (12") inches above the top of pipe.
 - e. Place pipe that is to be concrete encased in proper position on temporary supports consisting of wood blocks or bricks with wood wedges. When necessary, anchor or weight the pipe to prevent flotation when the concrete is placed.
 - f. Place concrete for embedment or encasement uniformly on each side of the pipe and deposit at approximately its final position. Do not move concrete more than five (5) feet from its point of placement.
4. Pipe Laying
 - a. Pipe laying shall not proceed if the trench width as measured at the top of pipe

exceeds the maximum allowable trench width. If this occurs the Contractor shall provide, to the approval of the Engineer better bedding for the pipe or pipe of sufficient strength to provide safe supporting strength.

- b. Store and handle pipe and fittings with care to prevent damage thereto. Do not use hooks to transport or handle pipe or fittings. Do not drop pipe or fittings.
- c. Rejected pipe and fittings shall be marked and removed from the Project Site at no cost to the Owner. Examine pipe and fittings for soundness and specification compliance prior to placement in the trench.
- d. Clean joint contact surfaces prior to jointing. Use lubricants, primers, or adhesives as recommended by the pipe or joint manufacturer.
- e. Pipe laying normally shall begin at the lowest point.
- f. Unless otherwise required, lay all pipe straight between manholes. Excavate bell holes for each pipe joint. When jointed, the pipe shall form a true and smooth pipeline.
- g. Plug pipelines at the end of each day's progress. Utilize plugs or other positive methods of sealing at all times to protect any existing system from entrance of stormwater or other foreign matter.

Contractor shall reconnect the existing active service connections and activate the sewer line as directed by the Engineer.

5. Building Service Laterals

- a. Unless otherwise noted on the plans, all active service connections on sewer segments to be abandoned or removed and replaced shall be connected to the proposed sanitary sewer. Contractor shall be responsible for locating service connections prior to construction.
- b. Install tees at an angle of no more than forty-five (45) degrees or less with pipe springline, for pipe sizes 8 through 21-inch diameter.
- c. Reconnection of building service shall include replacement of service lateral and new service line as directed by Engineer.
- d. Install Building service lines with a straight alignment and at a uniform grade not less than two (2) percent unless otherwise specified. Embedment shall be same as main sewer. When a building service line grade exceeds twenty (20) percent, pipeline anchors shall be installed as required for anchors, with the first anchor not more than twelve (12) nor less than seven (7) feet upstream of the wye.
- e. Maintain an accurate record for submittal to the Engineer of location, size and direction of each tee, saddle and/or location, size and length of each building service line. Locations shall use the pipeline stationing as shown on the Plans, or the

distance from the first downstream manhole.

- f. Contractor shall verify by testing all service connections to determine if they are active or inactive. Only active services shall be connected to the existing sanitary sewer system. Inactive services shall be plugged with hydraulic cement. In addition, the Contractor shall be responsible for any liability associated with the accidental plugging of active services.
- g. All service laterals shall be inspected by the Owner's Representative prior to reconnection to the replacement sewers. If the service laterals are found to be in a deteriorated condition in the opinion of the Owner's Representative, then the Contractor shall replace the service lateral to the property line as directed by the Owner's Representative.
- h. All service lateral tee connections shall be ductile iron Class 50. Service lateral wye connections shall be PVC SDR 26.
- i. No bends greater than 45 degrees shall be allowed in service laterals.

6. Extension of Service Laterals

Service laterals which require a connection to the relief/replacement sewer greater than four (4) feet in length, measured horizontally, shall be considered a service lateral extension. The service location for all abandoned, replacement, or relief sewer shall be determined prior to excavation. The extension pipe shall be laid to provide sufficient slope to the new sanitary sewer not less than two (2) percent unless otherwise specified. All building lateral extensions on private property shall be made by a licensed Master plumber.

7. Anchors

Anchor pipelines in accordance with the table below:

PIPELINE ANCHORS

<u>Percent of Grade</u>	<u>Center to Center Max. Spacing (Feet)</u>
0-20	Not Required
20-35	36
35-50	24
> 50	16

The anchor shall be made of concrete or other material approved by the Engineer. Concrete anchors shall have a minimum thickness of twelve (12) inches. The anchor shall extend not less than one (1) foot into undisturbed earth on the sides and bottom and one (1) foot above top of pipe. In incompressible material, the above dimensions may be six (6) inches each side and bottom. The anchor shall support a joint fitting.

8. Connection of Pipes of Dissimilar Materials

Connect different pipe materials using proprietary transition couplings, that will provide permanent and watertight connections which will withstand the hydrostatic test pressure.

9. Sewer Pipe and Water Main Separation

Sanitary sewers, house sewers or storm drains that are laid in the vicinity of pipelines designated to carry potable water shall meet the following conditions.

a. Parallel Installation - Sewers and Water Mains

- 1) Normal Conditions - Any sanitary sewer, storm sewer or sewer manhole shall be located at least ten (10) feet in all directions from water mains, whenever possible; the distance shall be measured from edge to edge.
- 2) Unusual Conditions - Where the ten (10) foot separation cannot be achieved, the vertical separation shall be a minimum of two (2) feet between outside diameters and the horizontal separation shall be a minimum of four (4) feet. The sewer shall be located below the water main.

b. Crossings - Sewers and Water Mains

- 1) Normal Conditions - A vertical separation of at least 18 inches shall be maintained between any potable water supply and sanitary sewers.
- 2) Unusual Conditions - When local conditions prevent a vertical separation as described above, the water main can be relocated with the approval of the Engineer.

10. Drainage Course Crossing

Pipelines that cross well-defined drainage courses and have less than three (3) feet of cover shall be ductile iron or concrete encased. The length of ductile iron pipe or concrete encasement shall be as indicated, or if not indicated, as specified by the Engineer.

11. Polyethylene Wrapping

Polyethylene material for pipe encasement and all ductile iron pipe shall meet the requirements of ANSI/AWWA C105/A21.5-82, or latest revision thereof.

12. Non-Metallic Water and Sanitary Sewer Pipe Detection Tape

Detectable underground utility warning tapes which can be located from the surface by a pipe detector shall be installed above non-metallic pipe at all locations and above ductile iron pipe only where pipe crosses existing or other proposed utilities.

Installation of detectable tapes shall be per manufacturer's recommendation and shall be as close to the grade as is practical for optimum protection and detectability. Allow a minimum of 18 inches between the tape and the line.

13. Backfill

Backfill trenches as specified in Section D2-10 - Backfill. Clay dams or concrete dams (1500 psi minimum) shall be placed at locations as shown on the Contract Drawings, or as directed by the Engineer.

14. Testing

Test new sanitary sewers in accordance with Section D1-8 – Sanitary Sewer Repair Testing. Test replacement sewers (where previous cross connections with storm sewers existed) in accordance with Section D1-8 Sanitary Sewer Repair Testing.

15. Bypass Pumping

Perform bypass pumping for flow control. No bypassed wastewater shall discharge to natural or manmade drainage structures.

16. Abandonment of Existing Manholes

- a. Prior to the abandonment of a manhole, Contractor shall verify that no existing services will be affected.
- b. The top of the manhole shall be lowered to an elevation at least 24 inches below final grade.
- c. All pipes shall be plugged with hydraulic cement, to a minimum depth of one (1) foot. After the cement has set, the manhole shall be filled with thoroughly tamped sand or CA-7 grade base. Surface restoration shall be compatible with surrounding surface.
- d. Frames and covers shall be removed from the site.

17. Pipe Plugging and Sanitary Sewers to be Abandoned

- a. Prior to the plugging of a sewer segment, Contractor shall verify that no existing services will be affected.
- b. Physically remove sanitary sewer pipe outside of the manhole for a minimum distance of one foot.
- c. Fill pipe for a minimum length of one foot with hydraulic cement. Fill void outside of manhole with hydraulic cement, and repair manhole wall.

18. Clay Dams

When shown on the construction plans, the Contractor shall place cutoff trench dams of native clay or impervious soil across and along the trench at 150-foot intervals to retard and resist the movement of groundwater through the trench. The trench dams shall be carefully compacted and shall be 6 feet in length, as measured along the sewer centerline and shall be benched into the undisturbed trench sides from the subgrade or top of cradle, to within 5 feet of the existing surface, or if in rock or hardpan, shall extend to the top thereof

whichever is greater. Where pipe cover is less than 5 feet the dam shall extend to within 1 foot of the existing surface. The trench dam installation shall have as a minimum 3 feet of compacted material above the crown of the pipe.

D. Measurement and Payment

1. Sewer Pipe

Sewer pipe of the respective type, size, and/or strength including specified pipe embedment (other than concrete), and testing will be paid for at the Contract Unit Price per linear foot of pipeline actually required and installed, measured along the centerline of the pipeline from center of manhole to center of manhole. This item includes costs for location of existing services, excavation, existing pipe removal and disposal (for open cut only), furnishing and placing pipe embedment materials, tees, furnishings and placing pipe, fittings and joint material, making connections to pipe of dissimilar materials, making connections to manholes, backfill, testing, and any resulting restoration and repairs and incidental and appurtenant work required to complete the item.

2. Trenching

Cost of all work necessary to complete trenching shall be incidental to the related bid item.

3. Connect Service Laterals

Payment for connection of service laterals to the proposed replacement/relief sewer shall be incidental to the related bid item

4. Installation of Service Lateral Cleanout

Payment for installation of service lateral cleanouts shall be incidental to the related bid item.

5. Internal Television Inspection

Payment for internal television inspection and cleaning shall be considered a subsidiary obligation of the Contractor and shall be included in the bid price for the item affected thereby.

6. Concrete Encasement of Sewer Pipe

Payment for installation of concrete encasement where indicated on the plans or as directed by the Engineer, shall be incidental to the related bid item

7. Sewer Main Pipe and Water Main Separation

When a minimum vertical clearance of three (3) feet cannot be maintained between sanitary sewer main and water main, the sanitary sewer main shall be ductile iron pipe. Compensation for excavation, furnishing and placing pipe embedment material, tees,

furnishing and placing pipe, fittings and joint material, making connections to pipe of dissimilar materials, backfill, polywrap, testing and any resulting repairs and incidental and appurtenant work shall be incidental to the related bid item.

8. Sewer Main Pipe and Storm Sewer Conflict

When conflicts occur between sanitary sewers and storm sewers, the sanitary sewer main shall be ductile iron pipe. Compensation for excavation, furnishing and placing pipe embedment material, tees, furnishing and placing pipe, fittings and joint material, making connections to pipe of dissimilar materials, backfill, polywrap, testing and any resulting repairs and incidental and appurtenant work shall be related bid item.

9. Abandon Manhole

Abandonment of manholes, if there are any, shall be incidental to the related bid item

10. Pipe Plugging and Sanitary Sewers to be Abandoned.

Pipe plugging and abandoning of sanitary sewers shall be incidental to the related bid item

11. Installation of Aerial Creek Crossing

Payment for installation of concrete piers, steel encasement, concrete encasement, and anchors associated with the aerial crossing incidental related bid item.

12. Clay Dams

Payment for clay dams shall be incidental to the related bid item

13. The unit price for sanitary sewer pipe replacement shall be eligible for 60 percent after the replacement is made, an additional 10 percent is eligible after testing is complete and an additional 30 percent is eligible after restoration is complete.

END OF SECTION D2-13

D2-14 SERVICE CONNECTION REPAIR

A. General

1. It is the intent of this portion of this specification to provide for the rehabilitation of service lateral main line connections, by the installation of a resin-impregnated, flexible, felt tube inverted into the existing service lateral utilizing a pressure apparatus positioned in the mainline pipe. Curing shall be accomplished by ambient cure or other approved method to cure the resin into a hard impermeable pipe-within-a-pipe. When cured, the service lateral connection repair shall extend over the length of inversion in a tight fitting, watertight pipe-within-a-pipe to effect a watertight seal with the rehabilitated lateral pipe.

B. General Corrosion Requirements

1. The finished cured-in-place service lateral connection repairs shall be fabricated from materials which when cured will be chemically resistant to withstand internal exposure to domestic sewage.

C. CIP Service Lateral Main Line Connection Repair Materials

1. A flexible, felt tube shall be fabricated to a size that when installed will neatly fit the internal circumference of the conduit specified by the specifications. Allowance shall be made for circumferential stretching during insertion.
2. The length of the lateral liner shall range from 14" to 18".
3. The minimum length of the mainline liner shall be 16" and cover 360° of the main line pipe.
4. The Contractor shall take care to ensure that the liner extends to the service connection at the main creating a watertight seal with the main liner, but that no portion of the lateral liner protrudes into the main at the completion of installation.
5. Liner Material and Cured Lining
 - a. The lining material shall be a polyester fiber felt tubing, lined on one side with polyethylene or PPE and fully impregnated with a liquid thermosetting resin as specified. Minimum lining thickness shall be 4.5 mm. The In-place thickness shall be a minimum of 3 mm. The polyester felt tubing, including the polyethylene covered felt and thermosetting resin, shall meet the liner's manufacturer's standards.
6. Inspection and Testing: Inspection and testing shall be performed by the Manufacturer's quality control personnel in conformance with applicable standards. Testing shall be witnessed by the City or the City's authorized agent. The Contractor shall provide three (3) copies of certified test reports indicating that material does conform to the specifications.

11. Handling: The Manufacturer and Contractor shall use equipment and methods adequate to protect the pipe, joint elements and prevent shock contact of adjacent units during moving or storage. Damaged sections that cause reasonable doubt as to their structural strength or water-tightness will be rejected.
12. Requirements: The liner tube shall meet the following requirements.
 - a. The tube shall be fabricated to a size that when installed will tightly fit the internal circumference and length of the original pipe. Allowance shall be made for circumferential stretching during inversion.
 - b. The outside layer of the tube (before inversion) shall be plastic coated with a translucent flexible material that clearly allows inspection of the resin impregnation (wet out) procedure. The plastic coating shall not be subject to delamination after curing.
 - c. The tube shall be homogeneous across the entire wall thickness containing no intermediate or encapsulated elastomeric layers. No material shall be included in the tube that is subject to delamination in the cured CIPP. No dry or unsaturated layers shall be evident.
 - d. The wall color of the interior pipe surface after installation shall be a light reflective color so that a clear detailed examination with closed circuit television inspection equipment can be made.
 - e. The resin system shall be a 100% solids, epoxy or silicate based system.
13. The layers of the cured lateral shall be uniformly bonded. It shall not be possible to separate any two layers with a probe or point of a knife blade so that layers separate cleanly or the probe or knife blade moves freely between the layers; nor shall separation of the layer occur during testing performed under the requirements of this specification.

D. Installation Procedures

1. The following installation procedures shall be adhered to unless otherwise approved by the Engineer or the Engineer's authorized representative.
 - a. Access – The Contractor shall have access to the service lateral through the mainline. If a cleanout is available, the contractor shall have access through it only with written permission from the HOMEOWNER.
 - b. Safety – The Installer shall carry out his operations in strict accordance with all applicable OSHA standards. Particular attention is drawn to those safety requirements involving entering confined spaces.
 - c. Cleaning of Sewer Line – It shall be the responsibility of the Installer to remove internal debris out of the sewer line prior to lining.
 - d. Inspection of Pipelines – The interior of the pipeline shall be carefully

video inspected to determine the location of any conditions which may prevent proper installation of CIP Service Lateral Connection Repair into the service lateral, and it shall be noted so that these conditions can be corrected. **The post video shall include a 360° view of the mainline lateral liner transition to the mainline and a downstream view of the lateral liner transition to the lateral pipe on ALL laterals which have a cleanout.** A video recording and suitable log shall be provided to the City.

- e. It is required that the service lateral be inactive during the time of installation. This is normally accomplished by requesting the homeowner relinquish using their sewer services during the required period of installation and then notifying homeowner when the work is complete.
- f. Line Obstruction - If inspection reveals an obstruction or defect that cannot be removed by conventional sewer cleaning equipment, then the Contractor shall make a point repair excavation to uncover and remove or repair the obstruction. **Such excavation shall be approved in writing by the City or the City's authorized representative prior to the commencement of the work and shall be considered as a change order.**
- g. The mainline pipe opening (lateral connection to the main) shall be prepared to accept the CIP Service Lateral Repair Liner and the reconstructed mainline pipe opening shall be maximized to obtain the best possible connection.

E. Mainline Connection/Interface Seal/Lateral Lining

1. The installation of the CIP service lateral connection repair shall include a minimum 16-inch length CIP repair covering 360° of the mainline sewers (5-inches on either side of a 6-inch lateral). The lateral tube and the mainline liner section will consist of flexible needled felt or an equivalent non-woven material. The lateral tube shall have a uniform wall-thickness and be capable of conforming to offset joints/disfigured lateral pipe sections. The mainline liner will be sized according to the mainline sewer diameter and create a watertight seal to the main. This wall thickness shall taper at the ends providing a smooth transition. Installation will be accomplished remotely from the mainline pipe using air or water for inversion and curing. The cured pipe repair system shall be watertight and shall conform to the existing pipe and eliminate any leakage at the mainline/lateral interface.
2. The cured-in-place mainline/lateral liner connection repair system shall be a "LCR-Liner System" as manufactured by EPROS, "T-Liner" as manufactured by LMK or approved equivalent.
3. The final Service Lateral Connection Repair CIPP installation shall conform to the minimum structural standards as listed below:

<u>Final CIPP</u>	<u>ASTM Standard</u>	<u>Results</u>
Flexural Stress	ASTM D790	4,500 psi
Flexural Modules of Elasticity	ASTM D790	400,000 psi

F. Payment

Service connection repair shall be paid for in accordance with Section SP4.

END SECTION D2-14

D2-17 RESTORATION

A. General

1. Restore the project site to conditions not less than that existing prior to starting construction unless otherwise required by these specifications.
 - a. Coordinate surface restoration work with the affected private property owners.
 - b. Private property over which the Owner has prior rights (i.e. utility easement, sewer easement) and/or has obtained rights-of-way, licenses and/or agreements from the property owner to allow construction of a sanitary sewer pipeline and appurtenances, shall be restored in conformance with these Contract Documents.
 - c. Restore public property with strict adherence to the requirements of the public body having jurisdiction therein.
 - d. No restoration shall occur until testing is complete and accepted by the Owner's Representative.
 - e. Complete final surface restoration within three weeks of the sewer installation or repair or as directed by the Owner's Representative.
2. Reference Standards

Surface restoration including pavement, driveways, sidewalks, curb and gutters, and sodding shall be in accordance with the current edition of Illinois Department of Transportation Standard Specifications for Road and Bridge Construction (Adopted April 1, 2016), and these Specifications.

B. Materials

1. Topsoil
 - a. Topsoil shall be free from large roots, sticks, weeds, brush, stones or other litter and waste products. A minimum of 4 inches compacted depth of topsoil shall be used.

- b. The soil texture shall be classified as loam or sandy loam according to the following criteria:

		<u>Loam</u>	<u>Sandy Loam</u>
Sand	(2.0 to 0.05 mm diameter) (No. 10 sieve)	25-50%	45-85%
Silt	(0.05 to 0.002 mm diameter) (No. 270 sieve)	30-50%	Less than 50%
Clay	(smaller than 0.002 mm diameter) (Hydrometer analysis)	5-25%	Less than 20%

- c. Soil texture shall be determined by utilizing processes as prescribed in ASTM D 422 using the No. 10 and No. 270 sieves and a hydrometer analysis.

2. Fertilizer

Fertilizer shall be a standard commercial 16-8-8, uniform in composition, free flowing and suitable for application with approved equipment, delivered to the site in bags or other convenient containers each fully labeled, conforming to applicable State laws.

3. Sod

- a. Sod shall be approved nursery or field grown grass that is native to the locality of the work and shall match existing in the area of excavation. Sod shall be well rooted in soil of such consistency that it will not break, crumble or tear during handling and placing. Sod shall be free of noxious weeds and other objectionable plants and shall not contain substances injurious to growth.
- b. Grass shall be between 1-1/2 and 4 inches in length when the sod is cut. The sod shall be cut within 48 hours of placement in rectangular pieces not less than 12 inches in width and not less than one inch in soil thickness. Keep sod in a moist condition between the initiation of cutting and the completing of placing and protect against exposure to the sun, wind, freezing during transportation to the site, and during storage prior to placing.

4. Seed

Grass seed shall be fresh and shall match existing grass in the area of excavation.

5. Portland Cement Concrete

Portland Cement concrete shall have a minimum compression strength of 3000 psi at 28 days, no less than 5 sacks of cement per cubic yard, and shall conform to ASTM C 94, Alternate 3. Reinforcement shall be 6" x 6" No. 4 x No. 4 Woven Wire Fabric. No. 4 dowel bars shall be provided on 3 foot centers, each side. Minimum length of extension into existing base shall be 12 inches.

6. Curing Compound

Commercial grade conforming to ASTM C 309, Type I.

7. Reinforcing Steel

Conform to ASTM A 615, Grade 40.

8. Asphalt Cement

Asphalt cement for binder shall be AC 85-100 paving asphalt conforming to the Standard Specifications unless otherwise specified.

9. Prime Coat

Asphalt to be used for a prime coat shall be asphalt emulsion Type RS-2, CRS-2, or liquid asphalt MC-70, MC-250, or RC-250 conforming to ASTM D 977, D 2397, D 2027, or D 2028.

10. Tack Coat

Asphalt emulsion conforming to ASTM D 977 or D 2397, unless otherwise specified.

11. Asphalt Concrete

Asphalt concrete for paving the designated area shall be Class A-3 and all materials shall conform to the requirements of Section 403 of IDOT Standard Specifications for Road and Bridge Construction, edition April 1,2016. Portions of the referenced specification that are obviously not applicable for the type of work to be done shall be disregarded.

C. Execution

1. Cleanup

Upon completion of installation and backfill operations, clean and dress up the work area as follows.

- a. Remove construction debris and litter from the site.
- b. Remove excess excavation material from the site including material which has washed into stream beds, storm water facilities, streets, culverts, etc.
- c. Remove tools, equipment and construction materials except for designated storage areas. Maintain designated storage areas in a neat appearing manner.
- d. Restore surface and subsurface drainage and provide drainage wash checks necessary to prevent soils from being washed downstream.
- e. Machine or hand grade the area in preparation of final grading, seeding, sodding, pavement replacement, etc.

- f. Restore all street signs and mail boxes.
- g. Maintain adequate safety signs, barricades and lights until final restoration of work area is completed.

2. Finish Grading

Finish grade the area to lines and grades which existed prior to the area being disturbed, with special attention directed to proper surface drainage, and the refilling of settled excavations with earth compacted to densities required. The area shall be smoothed by raking or dragging. Flower and vegetable gardens in existence prior to this project shall have the separately stored topsoils restored unless otherwise required. Areas to be sodded or seeded shall have a minimum four-inch depth of topsoil.

3. Sod

- a. Restore grassed areas disturbed by construction with sod to match existing. Sod may be placed between the average date of the last freeze in the Spring and six weeks prior to the average date for the first freeze in the Fall U.S. Weather Bureau for the area unless otherwise approved by the Owner's Representative in writing. Place sod at any time during this period except when the temperature is over 90 degrees Fahrenheit, drought conditions exist or the sod or ground surface is frozen. Cut sod as thick as possible to aid the sod in taking root at the earliest possible date.
- b. Spread fertilizer nutrients over the area at a rate of 160 pounds per acre (nutrient weight only) or as recommended by the manufacturer.
- c. Place sod on the prepared surface with the edges in close contact and the alternate courses staggered. Bury exposed edges of the sod flush with the adjacent soil. In ditches, place sod with the longer dimension perpendicular to the flow of the water in the ditch. On slopes, starting at the bottom of the slope, place sod with the longer dimension perpendicular to the slope of the ground and where the slope is 2:1 or greater, stake the sod. Sod shall be rolled after placement and joints filled between sections with scarified soil. Within eight hours after placing the sod, apply five gallons of water per square yard.
- d. Provide sufficient water to prevent the sod from drying out.
- e. Existing sod which was salvaged during construction may be reused at the contractor's option.
- f. Sod shall have taken root before acceptance. Contractor shall guarantee sodding one year after acceptance by the Owner.

4. Seeding

- a. The areas to be restored by seeding shall be only as directed by Engineer. Seed bed preparation shall not be started until all stones, boulders, and debris larger than 3 inches in diameter have been removed. The area to be seeded shall be worked to a minimum depth of 3 inches with a disk or other method approved by the Engineer, reducing all soil particles to a size not larger than 2 inches in diameter. The

prepared surface shall be relatively free from all weeds, stones, roots, and sticks. No seeds shall be sown until the seed bed has been approved by the Engineer.

- b. Spread fertilizer nutrients over the area at a rate of 160 pounds per acre (nutrient weight only) or as recommended by the manufacturer.
- c. Mechanically apply grass seed.
- d. Do not seed during high winds or when the seed bed is too wet for working. Within 12 hours lightly rake seeded areas and roll with a 200-pound roller. After raking and rolling, water the seeded areas with a fine spray until a uniform moisture depth of one inch has been obtained. In lieu of mechanical application of seed, hydraulic application may be used. The seed slurry shall be constantly agitated until pumped from the tanks. The seed shall not be allowed to set in water more than four hours before application.
- f. Water seeded areas as required for the seed to maintain suitable growth for at least three mowings performed a minimum of one week apart.
- g. Reseed areas where the grass did not take.

5. Tree, Bush, and Hedge Transplanting and Replacement

- a. Existing trees, bushes, and hedges which cannot be tied back or trimmed to prevent damage and require removal because of the proposed construction shall be transplanted with a tree spade or replaced. Tree removal shall include removal of stump and roots four inches below grade. Transplanting shall be at the location directed by the Owner's Representative. After digging the plants, properly store them until they can be transplanted. Replacement plants shall not be delivered until they can be planted.
- b. Plant during the proper seasons. Do not plant in frozen soil or during unfavorable weather conditions. Dig tree pits of such size as to provide ample space for the entire root system, as the tree comes from the nursery, without crowding or bending the roots. The pits shall be 12 inches wider than the ball diameter, have vertical sides, and be six inches deeper than the thickness of the ball.
- c. Thoroughly loosen the soil in the bottom of the pit by spading to a depth of six inches. Dig holes immediately before planting. Dispose of soil earth dug from the tree pits.
- d. Set trees at a depth slightly below finished grade, half-fill the hole with planting soil and thoroughly water. Loosen and fold down the upper half of the burlap, fill the hole with planting soil and thoroughly water. Fill the top two inches with a well-rotted mulch.
- e. After planting, prune the branches in proportion to the amount of root system lost in the transplanting operations but in such a manner as to retain the form typical of the tree. In general, remove approximately one-third of the branch structure. Pruning shall be done by expert workmen in such a manner as to insure healthy and symmetrical growth of new wood.

- f. After planting, wrap trunks of trees planted after October 15 with special tree wrap from the crotch of the first major branches down to the ground. Tie wrapping with cotton twine to keep the wrapping in place.
 - g. Plant trees vertically. Trees found leaning during the guarantee period shall immediately be staked with two 2-inch by 3-inch wood stakes, eight feet long, pointed on one end. The stake shall be long enough to properly support the tree. Drive the stakes to a depth of 18 inches below the bottom of the tree pit. Locate the stakes on the north side and on the south side of the tree, and 12 inches to 18 inches from the trunk. Do not drive stakes into the ball and burlap. Guy the trees using a figure eight hitch consisting of No. 14 gauge wire encased in a section of rubber hose.
6. Restoration of Pavement Surfaces
- a. General
 - 1) Restore (unless otherwise specified or ordered by the Owner's Representative) permanent type pavements, sidewalks, driveways, curbs, gutters, and surface structures removed or disturbed during or as a result of construction operations to a condition which is equal in appearance and quality to the condition that existed before the work began. The surface of all improvements shall match the appearance of the existing surface.
 - 2) Pour concrete only after inspection by the Engineer of the pouring site to verify proper forms and reinforcement. Reinforcement shall be equal in quantity and type of materials to reinforcement that existed prior to the work, or as indicated in the plans or specifications.
 - 3) Sawcut existing paved surfaces to provide a straight joint between the existing and new surface. Sawcutting shall be full depth and square or rectangular in shape.
 - 4) Cure and protect all exposed concrete installed under this contract in accordance with the reference standard.
 - 5) Allow concrete to attain a minimum 7 day strength before allowing traffic or construction equipment on the concrete.
 - b. Concrete Sidewalks
 - 1) When removing portions of a concrete sidewalk, an entire "Square" shall be removed. Removal of a partial sidewalk "Square" shall not be allowed.
 - 2) Sidewalk replacement shall be constructed according to the Sidewalk Restoration Detail Drawing provided in the construction drawings and Illinois Department of Transportation Standard Specifications for Road and Bridge Construction (April 1, 2016)
 - c. Concrete Curb and Gutter

Curb and Gutter Removal and Replacement shall be constructed per Detail Drawing provided in the construction drawings and Illinois Department of Transportation Standard Specifications for Road and Bridge Construction (April 1, 2016)

d. Concrete Driveways

Replace concrete driveways to the condition and thickness which existed prior to construction. Minimum thickness shall be 6 inches.

e. Bituminous Concrete Driveway

Replace bituminous driveways to the condition and thickness which existed prior to construction. Minimum thickness shall be 2 inches. Construction shall be executed in accordance with details provided in construction drawings.

f. Tack Coat

Apply a tack coat on existing asphalt concrete pavement and to each lift of new pavement that is to receive a succeeding lift in conformance with Illinois Department of Transportation Standard Specifications for Road and Bridge Construction (April 1, 2016).

g. Prime Coat

The prime coat shall be applied to the leveling course in accordance with related section of the referenced specification at the rate of 0.30 gallons per square yard of surface area. The exact amount is to be determined by the Engineer.

h. Construction of Asphalt Concrete Pavement

Lay asphalt concrete over the base course in a single lift and the compacted depth shall be 3-inches. The method of proportioning, mixing, transporting, laying, processing, rolling the material, and the standards of workmanship shall conform to the applicable requirements of Illinois Department of Transportation Standard Specifications for Road and Bridge Construction (April 1, 2016).

The Engineer will examine the base before the paving is begun and bring any deficiencies to the Contractor's attention to be corrected before the paving is started. Roll each lift of the asphalt concrete and compact to the density specified in the referenced Standard Specification. The grade, line, and cross section of the finished surface shall conform to the directions of the Engineer. Asphalt or asphalt stains which are noticeable upon surfaces of concrete or materials which will be exposed to view shall be promptly and completely removed.

i. Weather Conditions

Asphalt shall not be applied to wet material. Asphalt shall not be applied during rainfall, sand or dust storm, or any imminent storms that might adversely affect the construction. The Engineer will determine when surfaces and material are dry enough to proceed with construction. Asphalt concrete shall not be placed (1) when the atmospheric temperature is lower than 40 degrees F, (2) during heavy rainfall, or

(3) when the surface upon which it is to be placed is frozen or wet. Asphalt for prime coat shall not be applied when the surface temperature is less than 50 degrees F. Exceptions will be permitted only in special cases and only with prior written approval of the Engineer.

j. Concrete Pavement

Pavement replacement shall be the same thickness as that removed, except that in no instance shall it be less than a minimum of 6-inches. Protect the newly placed concrete from traffic for a period of 7 days and cure by covering with burlap, sand, earth, or sawdust, which is kept continuously wet.

Handle and place concrete pavement in accordance with the Illinois Department of Transportation Standard Specifications for Road and Bridge Construction, edition April 1, 2016.

k. Gravel Surfacing

Where required by the Drawings, and where necessary to match existing surfaces, place crushed rock, gravel surfacing material, as specified herein, on streets, driveways, parking areas, street shoulders, and other graveled areas disturbed by the construction. Spread the rock by tailgating and supplement by hand labor where necessary. Level and grade the rock to conform to the existing grades and surfaces.

D. Measurement and Payment

1. Payment for restoration associated with other work items, including but not limited to, manhole rehabilitation, point repairs and cross connections shall be included in the unit price for the applicable work item.
5. If restoration work is not completed, 50 percent of the Contract Price will not be eligible for payment.

END OF SECTION D2-17

D2-18 TREE PROTECTION AND PRUNING

A. General

1. Description

This work shall consist of furnishing, installing, and maintaining tree protection for trees designated and approved by the engineer to be protected from construction activities.

2. No trees or cultured plants shall be cut, trimmed or removed unless clearly shown on the plans or marked by the Engineer. All trees and other vegetation which are so marked and must be removed to perform the work, shall be removed and disposed of by the Contractor. No on-site burning shall be permitted.
3. All protection of trees, trimming, root cutting, and repair of trees and plants shall be performed by qualified nurserymen or horticulturist.
4. All trees shown on these plans to be retained shall be protected during all phases of demolition/construction with temporary fencing.
5. Tree protection fences shall be installed prior to the commencement of any site preparation work.
6. The Contractor shall not be required to replace trees within existing easements except as noted on plans. All reasonable effort will be made to save existing trees in accordance with this section.

B. Materials

1. Tree Protection Fencing

a. Fencing Post:

Fencing posts shall be standard 6'-0" metal T-Post.

b. Fencing:

Fencing shall be standard plastic safety fencing, orange in color.

C. Execution

1. Assembly

Fencing posts shall be installed at 6'-0" on center. Safety fencing shall be installed and fastened securely to the T-Post with steel tie-wire and/or plastic tie-wraps.

2. Tree protection fencing shall be installed 5'-0" outside the drip line of the tree.

D. Measurement and Payment

1. The cost of tree protection and pruning shall be incidental to the contract. The cost shall include all labor, equipment, materials, and other appurtenances for the complete protection of all trees as designated by the Engineer as shown on both plans and/or as directed by the Engineer.

END OF SECTION D2-18

D2-20 MOBILIZATION

A. General

1. Description

- a. This work shall consist of scheduling and mobilizing equipment, materials and personnel necessary to pursue the work under contract.
- b. Shall include demobilization, which shall consist of removal and transporting from the site all personnel, tools, equipment, and materials mobilized by the Contractor. It shall also consist of clean-up of the work area to the satisfaction of the Owner's Representative.

B. Materials

No construction materials are required for the item.

C. Execution

1. Contractor shall set up operations on site with supervision and labor and shall move in and place the equipment and materials required for carrying out the work covered by this contract.
2. Payment for this item will be based on the contract lump sum bid price for mobilization and bond. When payments become due, partial payments will be made as follows.
 - a. When 5% or more of the original contract amount is earned, 25% of the lump-sum price.
 - b. When 10% or more of the original contract amount is earned, an additional 25% of the lump-sum price.
 - c. When 25% or more of the original contract amount is earned an additional 25% of the lump-sum price.
 - d. When 50% or more of the original contract amount is earned, an additional 25% of the lump-sum price.

**Said lump-sum price shall include full compensation to the Contractor for labor, materials and equipment required for the complete mobilization of the Contractor onto the job site including portable sanitary facilities and all other incidental work related thereto and as shown on the project construction plans and specifications herein.

END OF SECTION D2-20

D2-21 BYPASS PUMPING

A. General

1. Description

The Contractor shall furnish all the necessary materials, equipment, tools, labor, and associated appurtenances to control the wastewater flow in conjunction with cleaning, television inspection, point repairs, obstruction removal, and other related works. Wastewater flow diversion must not cause flooding or damage to public or private property. The wastewater flow shall be bypassed while plugging the upstream manhole for the section of main being worked in areas to receive cured-in-place, pipe bursting, and other trenchless or open-cut applications as necessary.

B. Materials

No materials are listed for construction.

C. Execution

1. The Plugging or blocking typically includes insertion of a plug into the upstream manhole of the line section being worked. A plug in the downstream manhole also may be required to prevent any backflow. Bypass pumping typically includes flow diversion from the upstream manhole to the downstream manhole of the line section being worked.
2. When total bypassing and pumping are required, the pumps, conduits, and other equipment shall be supplied to divert the flow of wastewater around the line section where construction or rehabilitation work is to be performed. The total bypass system must have sufficient capacity to handle peak flow during a rainstorm. The Contractor is responsible for furnishing the necessary labor, supervision, and traffic control to set up and operate the pumping and bypassing.

D. Measurement and Payment

1. Bypass pumping is considered incidental to cured-in-place pipe installation and or installation and/or repair of sewer mains and manholes. No additional payment will be made for Bypass Pumping.

END OF SECTION D2-21

D2-22 TRAFFIC CONTROL

A. General

1. Description

It is the Contractor's responsibility to maintain adequate traffic control throughout the duration of the project. Traffic control protecting all work shall be provided in accordance with current state and national standards and as directed by the Engineer. Traffic control shall be in place as soon as construction begins.

B. Materials

No materials are listed for construction.

C. Execution

Traffic control and signage shall be in accordance with the current edition of the manual of Uniform Traffic Control Devices, along with the Illinois Highway Standards for Traffic Control. The Contractor shall provide the City Engineer a 48-hour notice prior to any lane closure.

D. Measurement and Payment

No additional payment will be made for Traffic Control. All Traffic Control shall be incorporated into the other pay items and shall not be paid for separately.

END OF SECTION D2-22

D2-23 STEEL ENCASEMENT PIPE/CARRIER PIPE INSTALLATION

PART 1 GENERAL

1.01 SUMMARY

A. Description

This section consists of constructing steel encasement pipe and installing water or sanitary sewer line within the encasement in accordance with these specifications and in conformity with the lines and grades and locations shown on the Drawings.

1.02 REFERENCES

A. ASTM A 139 – Electric Resistance Welded Steel Pipe.

B. ASTM A 211 – Spiral Welded Steel or Iron Pipe.

C. AWWA C 202 - AWWA Standard for Mill-Type Steel Water Pipe.

D. 29 CFR 1926 Subpart C -Occupational Safety and Health Standards – General Safety and Health Provisions.

1.02 QUALITY ASSURANCE

A. Check the elevation of each end of the steel casing to the planned elevation. The difference in elevation between ends shall be within 0.05 feet of plan requirements.

1.03 SUBMITTALS

A. Steel Casing Pipe

B. Casing Spacers

PART 2 PRODUCTS

2.01 CASING

A. Steel encasement pipes for this project shall be of the diameter(s) shown on the Drawings except that it shall be the Contractor's sole responsibility to ascertain that the casing spacers (Ranger Type II, Raci Spacers or approved equal)) are compatible with the inside diameter of the encasement pipe shown on the plans and shall be smooth wall, welded steel pipe conforming to the latest requirements of ASTM A139 Grade B, ASTM A211 or ASSA C202 (Grade B). The Contractor shall furnish and install encasement pipe of ample wall thickness to withstand all structural loading of whatever nature due to the site and/or soil conditions and the method of installation. All encasement pipe shall be new. Used pipe shall not be allowed. The minimum wall thickness for the various nominal diameters shall be as follows:

Carrier Pipe (in.)	Minimum Encasement Pipe (in.)	Minimum Wall Thickness (in.)
4 – 8	16	1/4
10	20	1/4
12	24	1/4
15 – 18	30	5/16
20 – 24	36	5/16
27 – 30	42	7/16
30 – 36	48	1/2
42	54	9/16
48	60	9/16

- B. Use of the minimum wall thickness shall not relieve the Contractor from any responsibility to provide an acceptable installation of the encasement pipe to the line and grade and all other stipulations required by the Plans or specified herein.

PART 3 EXECUTION

3.01. INSTALLATION, GENERAL

All encasement pipe shall be installed by the dry boring and jacking method unless called out otherwise herein and/or on the Plans.

3.02 INSTALLATION BY BORING AND JACKING

- A. Installation of the encasement shall be carried out such that there will be no settlement of the ground surface above the encasement. The Contractor shall take all precautions to prevent caving of the soils ahead of the pipe. During encasement installation, the Contractor shall use all care to minimize annular space (voids) between the outside of the encasement pipe and the surrounding ground.
- B. The Contractor shall inspect the locations where the encasement pipe and bore pits are to be installed and familiarize himself with the conditions under which the work will be performed and with all necessary details for the orderly prosecution of the work. The omission of any details in the Plans and/or herein for installation of the encasement and carrier pipe shall not relieve the Contractor of full responsibility for the proper execution and integrity of the work.
- C. The Contractor shall satisfy himself of soils condition by any means he deems necessary, i.e., exploratory boring or exploratory pit excavations at bore ends. Any such exploratory work shall be done so as to not jeopardize railroad or highway roadbeds and rights-of-way and shall be backfilled and cleaned up to the satisfaction of the rights-of-way owner. The Contractor shall be responsible to obtain his own permission and to furnish bonds, etc. as may be required by private landowners or the public or private authority having jurisdiction at the site of any such exploratory work.
- D. The Contractor shall perform all excavation required to complete the work regardless of the material encountered. Excavation from the access shafts (bore pits) in excess of that required to backfill the access shafts and open cut portion of the line shall be

disposed of by the Contractor outside the limits of the construction site. Pits and trenches shall be properly shored, sheeted, and braced.

- E. Any damage to the encasement pipe coating during shipment or handling shall be repaired by the Contractor. Boring and installation of smooth wall pipe shall be by competent supervisors and workmen specializing in this type of work that is provided by the Contractor.
- F. To maintain the designed slope of the sewer gradient, the horizontal and vertical alignment at all points on the encasement pipe and the carrier pipe shall be held to a tolerance of five-hundredths (0.05) of a foot of the designed line and grade. Encasement pipes and carrier pipes not meeting this tolerance shall be subject to removal and replacement at the Contractor's expense.
- G. During installation of the encasement pipe, care shall be exercised to minimize voids between the encasement and the surrounding ground.
 - 1. On encasement pipes of 12" and larger nominal diameter, the annular space between the encasement pipe and the ground shall be pressure grouted to eliminate all voids. Encasement pipes smaller than 12" shall also be grouted if so directed by the Owner/Engineer depending on soil conditions at the bore site identified at the time of encasement installation.
 - 2. When grouting encasement pipes of such diameter that entry by a worker is possible, the grout shall be injected through the encasement pipe wall through 1.5" diameter holes from the inside at one location for each 5.0' linear interval over the entire length of the encasement pipe. The sequence for grout injection locations shall be as follows:

<u>Locations (5' Spaces)</u>	<u>"Clock" Position</u>
1 st	12 o'clock
2 nd	3 o'clock
3 rd	12 o'clock
4 th	9 o'clock
5 th	12 o'clock

Repeat 2nd through 5th locations at 5-foot intervals for each location to end of the encasement pipe.

Note: The Contractor shall be responsible to ensure that all requirements of OSHA concerning entry of workers into confined spaces are followed.
 - 3. For encasement pipes too small to be entered for grouting as addressed above, the annular space may be pressure grouted by means of a 2" diameter external grout pipe attached to the outside of the encasement pipe. After the encasement pipe (and the grout pipe) are in place, the grout pipe shall be withdrawn as the grout is introduced.
- H. The access shafts (bore pits) for encasement installation shall be rectangular in plan view, approximately 20' x 10', unless shown otherwise on the drawings, with the longer dimension being in the direction of the encasement pipe. The bore pits shall be sheeted, shored, and braced on all sides as addressed herein. Sheeting shall be timber or steel piling of ample strength to safely withstand all structural loading of whatever

nature due to site and soil condition. The top of the sheeting shall be at a minimum elevation equal to the natural ground line as it existed prior to construction.

3.03. INSTALLATION IN OPEN CUT

- A. Installation of the encasement in open cut shall be carried out so that there will be no settlement of the ground surface above the encasement after the encasement is backfilled.
- B. The Contractor shall inspect the locations where the encasement pipe is to be installed and familiarize himself with the conditions under which the work will be performed and with all necessary details for the orderly prosecution of the work. The omission of any details in the Plans and/or herein for installation of the encasement and carrier pipe shall not relieve the Contractor of full responsibility for the proper execution and integrity of the work.
- C. The Contractor shall perform all excavation required to complete the work regardless of the material encountered and shall install all bedding and backfill according to their requirements in these Specifications. Pits and trenches shall be properly shored, sheeted, and braced.
- D. Any damage to the encasement pipe coating during shipment or handling shall be repaired by the Contractor.
- E. To maintain the designed slope of the sewer gradient, the horizontal and vertical alignment at all points on the encasement pipe and the carrier pipe shall be held to a tolerance of five-hundredths (0.05) of a foot of the designed line and grade. If the open cut encasement pipe is attached to the end of a bored encasement pipe, the Contractor shall be responsible to make the grade and alignment of the open cut pipe become a true continuation of the grade and alignment of the bored encasement pipe. Encasement pipes and carrier pipes not meeting this tolerance shall be subject to removal and replacement at the Contractor's expense.

3.04 CARRIER PIPE IN ENCASEMENT

- A. Installation of the carrier pipe in the encasement shall be accomplished so that neither the pipe nor the encasement is damaged. Care must be exercised to assure that the joints of the pipe are not over-deflected or pulled out during the process. The pipe shall be jointed and pushed or jacked through the encasement. Cables, chains, jacks or other equipment or devices used shall not be in direct contact with the pipe unless thoroughly padded.
- B. To maintain the designed slope of the sewer gradient, the horizontal and vertical alignment at all points on the encasement pipe and the carrier pipe shall be held to a tolerance of five-hundredths (0.05) of a foot of the designed line and grade at any point in the encasement pipe. Encasement pipes and carrier pipes not meeting this tolerance shall be subject to removal and replacement at the Contractor's expense.
- C. The carrier pipe barrel, regardless of its diameter, shall be substantially centered diametrically in the encasement. Permanent hold-down jacks or other devices, subject to the Owner's approval, shall be installed to prevent the carrier pipe from floating.
- D. Install casing spacers (Ranger Type II, Raci Spacers or approved equal) at locations

along the carrier pipe as recommended by the manufacturer, for the pipe size and lengths to be installed. Where specified in the Drawings, install joint restraints at each pipe joint within the casing.

- E. If, after installation of the carrier pipe, adequate stability has not been provided, in the opinion of the Engineer, the annular space between the carrier pipe and the inside of the encasement pipe shall be filled with sand or other material approved by the Engineer.
- F. After the carrier pipe has been installed in the encasement pipe, both ends of the encasement pipe shall be tightly bulkheaded, sealed, and vented with cap (APS Model AC Pull-on End or approved equal) as directed by the Engineer

PART 4 MEASUREMENT AND PAYMENT

- 4.01 Steel encasement pipe shall be measured per linear foot of encasement pipe installed in place by diameter of steel encasement pipe. This shall constitute all payment including labor, materials, casing spacers, joint restraints, end caps and any other item necessary to install encasement pipe in accordance with the Drawings and Specifications.
- 4.02 No separate payment will be made for carrier pipe or pipe embedment under this section.

END OF SECTION D2-23

D2-24 SPRAY APPLIED MANHOLE COATING

PART 1 GENERAL

1.01 SUMMARY

A. Description

1. This section includes materials and equipment required for protecting and/or rehabilitating concrete and masonry manholes and other underground vaults by monolithic spray-application of a high-build, solvent-free epoxy coating to eliminate infiltration, provide hydrogen sulfide (sulfuric acid) corrosion protection, repair voids and enhance structural integrity. Procedures for surface preparation, cleaning, application and testing are described herein.

1.02 REFERENCES

- A. ASTM D 4541 - Standard Test Method for Pull-Off Strength of Coatings Using Portable Adhesion Testers
- B. ASTM D 4787 - Standard Practice for Continuity Verification of Liquid or Sheet Linings Applied to Concrete Substrates
- C. ASTM D638 - Tensile Properties of Plastics.
- D. ASTM D790 - Flexural Properties of Unreinforced and Reinforced Plastics.
- E. ASTM D695 - Compressive Properties of Rigid Plastics.
- F. ASTM D4541 - Pull-off Strength of Coatings Using a Portable Adhesion Tester.
- G. ASTM D2584 - Volatile Matter Content.
- H. ASTM D2240 - Durometer Hardness, Type D.
- I. ASTM D543 - Resistance of Plastics to Chemical Reagents.
- J. ASTM C109 - Compressive Strength Hydraulic Cement Mortars.
- K. ACI 506.2-77 - Specifications for Materials, Proportioning, and Application of Shotcrete.

- L. ASTM C579 - Compressive Strength of Chemically Setting Silicate and Silica Chemical Resistant Mortars.
- M. NACE - The published standards of National Association of Corrosion Engineers (NACE International), Houston, TX.
- N. SSPC - The published standards of the Society of Protective Coatings, Pittsburgh, PA.
- O. ASTM D4414 – Standard Practice for Measurement of Wet Film Thickness by Notched Gages.

1.03 SUBMITTALS

- A. The following items shall be submitted in compliance of Section D1-3 - Submittals:
 - 1. Technical data sheet on each product used, including ASTM test results indicating the product conforms to and is suitable for its intended use per these specifications.
 - 2. Material Safety Data Sheets (MSDS) for each product used.
 - 3. Project specific guidelines and recommendations.
 - 4. Coating manufacturer's instructions and recommendations on surface preparation, application, and repair of discontinuities.
 - 5. Contractor Qualifications:
 - a. Manufacturer certification that Contractor has been trained and approved in the handling, mixing and application of the products to be used.
 - b. Certification that the equipment to be used for applying the products has been manufactured or approved by the protective coating manufacturer and Contractor personnel have been trained and certified for proper use of the equipment.
 - c. Five (5) recent references of Contractor (projects similar size and scope) indicating successful application of a high-build solvent-free epoxy coating by plural component spray application.
 - d. Proof of any necessary federal, state or local permits or licenses necessary for the project.
 - 6. Design details for any additional ancillary systems and equipment to be used in site and surface preparation, application and testing.

1.04 QUALITY ASSURANCE

- A. Contractor shall initiate and enforce quality control procedures consistent with applicable ASTM, NACE and SSPC standards and the protective coating manufacturer's recommendations.

1.05 DELIVERY, STORAGE, AND HANDLING

- A. Materials are to be kept dry, protected from weather and stored under cover.
- B. Protective coating materials are to be stored between 50 deg F and 90 deg F. Do not store near flame, heat or strong oxidants.
- C. Protective coating materials are to be handled according to their material safety data sheets.

1.06 SITE CONDITIONS

- A. Contractor shall conform with all local, state and federal regulations including those set forth by OSHA, RCRA and the EPA and any other applicable authorities.
- B. Contractor shall submit design and safety procedures to Engineer when confined space entry, flow diversion or bypass is necessary in order for Contractor to perform the specified work.

PART 2 PRODUCTS

2.01 EXISTING PRODUCTS

- A. Standard Portland cement or new concrete (not quick setting high strength cement) must be well cured prior to application of the protective coating. Generally, 28 days is adequate cure time for standard Portland. If earlier application is desired, compressive or tensile strength of the concrete shall be tested to determine if acceptable cure has occurred.
- B. Cementitious patching and repair materials shall not be used unless their manufacturer provides information as to its suitability and procedures for topcoating with an epoxy coating. Project specific submittals shall be provided including application, cure time and surface preparation procedures which permit optimum bond strength with the epoxy coating.

- C. Remove existing coatings prior to application of the new protective coating. Contractor shall maintain strict adherence to applicable NACE and SSPC recommendations with regard to proper surface preparation and compatibility with existing coatings.

2.02 WALL CLEANING MATERIALS

- A. Water Abrasive or Wet Abrasive Blast: Type and size of abrasive shall be selected to produce a surface profile that meets the coating manufacturer's recommendations.
- B. High Pressure Water: Water at 3500 psi minimum pressure.
- C. Cleaners: Cleaners shall be per coating manufacturer's recommendations.

2.03 REPAIR MATERIALS

- A. Repair materials shall be used to fill voids, structurally reinforce and/or rebuild surfaces, etc. as determined necessary by the Engineer and protective coating Contractor. Repair materials must be compatible with the specified epoxy coating and shall be applied in accordance with the manufacturer's recommendations.
- B. The following products may be accepted and approved as compatible repair basecoat materials for epoxy topcoating for use within the specifications:
 - 1. 100% solids, solvent-free epoxy grout specifically formulated for epoxy topcoating compatibility. The epoxy grout manufacturer shall provide instructions for trowel or spray application and for epoxy topcoating procedures.
 - 2. Factory blended, rapid setting, high early strength, fiber reinforced, non-shrink repair mortar that can be trowelled or pneumatically spray applied may be approved if specifically formulated to be suitable for epoxy topcoating. Such repair mortars shall not be used unless their manufacturer provides information as to their suitability for topcoating with an epoxy coating. Project specific submittals shall be provided including application, cure time and surface preparation procedures which permit optimum bond strength with the epoxy coating.

2.04 PROTECTIVE COATING MATERIAL

- A. A 100% solids, solvent-free two-component epoxy resin system thixotropic in nature and filled with select fillers to minimize permeability and provide sag resistance acceptable to these specifications (up to 125 mils in a single application). Use Raven Lining Systems' Raven 405 epoxy coating system, or approved equal.

2.05 PROTECTIVE COATING APPLICATION EQUIPMENT

- A. Manufacturer approved heated plural component spray equipment shall be used in the

application of the specified protective coating.

2.06 REPAIR MORTAR SPRAY APPLICATION EQUIPMENT (if spray applied)

- A. Spray applied repair mortars shall be applied with manufacturer approved equipment.

PART 3 EXECUTION

3.01 DIVERSION PUMPING

- A. If necessary, install and operate sewage diversion pumping equipment to maintain sewage flows without backup, overflow, or spill.

3.02 CLEANING AND SURFACE PREPARATION

- A. Remove dirt, grease, and debris from floor and interior walls of manhole using high pressure water and abrasive, and cleaners as necessary to prepare a roughened, bondable surface as recommended by the manufacturer.

3.03 ACCEPTABLE CONTRACTORS

- A. Repair mortar Contractors shall be trained to properly apply the cementitious mortar according to manufacturer's recommendations.
- B. Protective coating must be applied by a Certified Contractor of the protective coating manufacturer and according to manufacturer specifications.

3.04 EXAMINATION

- A. All structures to be coated shall be readily accessible to Contractor.
- B. Comply with local, state and federal regulatory and other applicable agencies with regard to environment, health and safety.
- C. Any active flows shall be dammed, plugged or diverted as required to ensure that the liquid flow is maintained below the surfaces to be coated. Flows shall be totally plugged and/or diverted when coating the invert. All extraneous flows into the manhole or vaults at or above the area coated shall be plugged and/or diverted until the epoxy has set hard to the touch. As an option, hot air may be added to the manhole to accelerate set time of the coating.
- D. Installation of the protective coating shall not commence until the concrete substrate has properly cured in accordance with these specifications.
- E. Temperature of the surface to be coated shall be maintained between 40 deg F and 120 deg F during application. Prior to and during application, care should be taken to avoid exposure of direct sunlight or other intense heat source to the structure being coated. Where varying surface temperatures do exist, care should be taken to apply the

coating when the temperature is falling versus rising (ie. late afternoon into evening vs. morning into afternoon).

3.05 SURFACE PREPARATION

- A. Contractor shall inspect all surfaces specified to receive a protective coating prior to surface preparation. Contractor shall notify Engineer of any noticeable disparity in the surfaces which may interfere with the proper preparation or application of the repair mortar and protective coating.
- B. All contaminants including: oils, grease, incompatible existing coatings, waxes, form release, curing compounds, efflorescence, sealers, salts, or other contaminants shall be removed.
- C. All concrete or mortar that is not sound or has been damaged by chemical exposure shall be removed to a sound concrete surface or replaced.
- D. Surface preparation method(s) shall be based upon the conditions of the substrate, service environment and the requirements of the epoxy protective coating to be applied.
- E. Surfaces to receive protective coating shall be cleaned and abraded to produce a sound surface with adequate profile and porosity to provide a strong bond between the protective coating and the substrate. Generally, this can be achieved with a high pressure water cleaning using equipment capable of 5,000 psi at 4 gpm. Other methods such as high pressure water jetting (refer to NACE Standard No. 5/SSPC-SP12), abrasive blasting, shotblasting, grinding, scarifying or acid etching may also be used. Detergent water cleaning and hot water blasting may be necessary to remove oils, grease or other hydrocarbon residues from the concrete. Whichever method(s) are used, they shall be performed in a manner that provides a uniform, sound clean neutralized surface that is not excessively damaged.
- F. The area between the manhole and the manhole ring and any other area that might exhibit movement or cracking due to expansion and contraction, shall be grouted with a flexible grout or gel.
- G. Standard Portland cement or new concrete (not quick setting high strength cement) must be well cured prior to application of the protective coating. Generally, 28 days is adequate cure time for standard Portland. If earlier application is desired, compressive or tensile strength of the concrete can be tested to determine if acceptable cure has occurred.
- H. All manhole castings shall be abrasive blasted and coated.

3.06 APPLICATION OF PROTECTIVE COATING

- A. Application procedures shall conform to the recommendations of the protective coating manufacturer, including material handling, mixing, environmental controls

during application, safety, and spray equipment.

- B. The spray equipment shall be specifically designed to accurately ratio and apply the specified protective coating materials and shall be regularly maintained and in proper working order.
- C. The protective coating material must be spray applied by a Certified Contractor of the protective coating manufacturer.
- D. Specified surfaces shall be coated by spray application of a moisture tolerant, solvent-free, 100% solids, epoxy protective coating as further described herein. For new manhole structures, spray application shall be to a minimum wet film thickness of 100 mils.
- E. Airless spray application equipment approved by the coating manufacturer shall be used to apply each coat of the protective coating. Air assisted spray application equipment may be acceptable, especially for thinner coats (<10 mils), only if the air source is filtered to completely remove all oil and water.
- F. If necessary, subsequent topcoating or additional coats of the protective coating should occur as soon as the basecoat becomes tack free, ideally within 12 hours but no later than the recoat window for the specified products. Additional surface preparation procedures will be required if this recoat window is exceeded.

3.07 TESTING AND INSPECTION

- A. During application a wet film thickness gage, such as those available through Paul N. Gardner Company, Inc. meeting ASTM D4414 - Standard Practice for Measurement of Wet Film Thickness of Organic Coatings by Notched Gages, shall be used to ensure a monolithic coating and uniform thickness during application.
- B. After the protective coating has set hard to the touch it shall be inspected with high-voltage holiday detection equipment. Surface shall first be dried, an induced holiday shall then be made on to the coated concrete surface and shall serve to determine the minimum/maximum voltage to be used to test the coating for holidays at that particular area. The spark tester shall be initially set at 100 volts per 1 mil (25 microns) of film thickness applied but may be adjusted as necessary to detect the induced holiday (refer to NACE RPO188-99). All detected holidays shall be marked and repaired by abrading the coating surface with grit disk paper or other hand tooling method. After abrading and cleaning, additional protective coating material shall be hand applied to the repair area. All touch-up/repair procedures shall follow the protective coating manufacturer's recommendations.
- C. Measurement of bond strength of the protective coating to the substrate can be measured in accordance with ASTM D4541. Any areas detected to have inadequate bond strength shall be evaluated by the Engineer. Further bond tests shall be performed in that area to determine the extent of potentially deficient bonded area and repairs shall be made by Contractor in strict accordance with manufacturer's

recommendations.

D. Manhole Testing – shall be according to related section

PART 4 MEASUREMENT AND PAYMENT

4.01 No separate payment will be made for work performed under this Section. Include cost of Spray Applied Manhole Coatings in the contract unit prices for manholes.

END SECTION D2-24

PROJECT SPECIAL PROVISIONS

FOR

2020 MASCOUTAH SEWER REHABILITATION PROJECT PHASE I

SP1: POINT REPAIR BY CURED-IN-PLACE-PIPE (CIPP) FIBERGLASS REINFORCED FELT, PU/PVC COATED, RESIN IMPREGNATED

1. Description:

It is the intent of this Specification to provide for the reconstruction of short lengths of pipelines conduits by the installation of a resin-impregnated flexible tube which is inflated in a short length of the pipeline to form a hard, impermeable, corrosion resistant pipe within a pipe. When cured, the cured-in-place-pipe (CIPP) will be formed to the original conduit. This reconstruction process can be used in a variety of gravity applications such as sanitary sewers and storm sewers. The impermeable Cured-In-Place- Pipe (CIPP) should be continuous, tight-fitting, chemical resistant and airtight.

2. Materials

2.1 The tube should consist of layered non-woven flexible needled felt tube with an inner PU/PVC impermeable coating and additional layer of reinforced chopped fiberglass and felt. The reinforced fiberglass shall extend at least 3 inches on each side of the inner felt tube to form smooth transitions on each end of the point repair. The tube shall have an impermeable PU/PVC coating. This coating will form the inner layer of the finished pipe and is required for enhancement of corrosion, flow, and abrasion properties. The tube shall be thermo-bonded to the prescribed circumference and length. It shall be capable of carrying resin, withstanding installation pressures, and curing temperatures. The tube should be compatible with a non-styrene resin system. The tube should be thermo bonded to a size that, when installed, will form to the internal circumference of the original pipe. Allowance should be made for circumferential stretching during installation.

2.2 Resin –The resin used shall be a high-grade 2-part, ambient cured, corrosion resistant formulation provided by Perma-Liner Industries, Inc. designed for the cured-in-place-pipe (CIPP). Only non-styrene resin formulations will be accepted. The point repair materials must meet or exceed the properties in Table 1.

3. Minimum Requirements

Table 1. Properties Shall Meet or Exceed the Following

	ASTM Test Method	Minimum Value
Flexural Strength	D790	4,500 psi
Flexural Modulus	D790	250,000 psi

Tensile Strength D638 3,000 psi

3.1 The CIPP shall be designed with the minimum properties in Table 1, taking into consideration the condition of the existing pipe.

4. Installation

4.1 The tube shall be impregnated with the thermosetting two-part resin.

4.2 The tube shall be properly oriented and loaded onto the Carrier Train for proper installation over the repair area.

4.3 The Carrier Train shall be pulled or winched to the damaged area and positioned by Closed Circuit TV camera guiding the installation. The installation shall follow the Manufacturers Process for inflation curing and stripping out.

5. Testing Requirements

5.1 Hydraulic Capacity- Calculations must support that the finished Cured-In-Place-Pipe (CIPP) shall have at least 100% of the full flow capacity of the original host pipe before rehabilitation. Calculated capacities may be derived using a commonly accepted roughness coefficient for the original pipe material. A typical roughness coefficient for the CIPP shall be as verified by third part test data.

6. Inspection

6.1 The installation may be inspected visually if appropriate, or by closed-circuit television. Variations from true line and grade may be inherent because of the conditions of the original pipe.

6.2 The finished CIPP should be continuous over the length of the repair area plus one foot extending into structurally sound pipe.

7. Clean Up

7.1 Upon acceptance of the installation work and testing, the installer shall reinstate the project area affected by the operations.

8. Payment

8.1 Payment for the work included in this section shall be paid at lump sum price.

END SECTION SP1

SP2: PROTRUDING TAP REMOVAL

1. Description:

For break-in service connections that protrude more than a 1/2 inch into the sewer, the Contractor shall remove the protruding portion of the tap in preparation for cured-in-place pipelining, grouting or other rehabilitation work. Cutters used shall be power-driven cutting devices (lateral cutters) designed to remove protruding taps. Cutters shall be capable of slicing laterally through cast iron, 3/4" rebar and anchors, clay tile, and concrete protruding into sewer lines.

The Contractor shall cut protruding taps so that protrusions are no greater than 1/2 inch. While using a protruding tap cutter, slow revolution per minute (RPM) will cut more effectively than rapid RPM. The Contractor shall maintain a steady flow and RPM while cutting and shall hydro-flush cut and broken pieces out of the sewer before proceeding to the next protruding tap. After the tap is cut, the TV operator shall pan up the service to show the extents of the cutting. If a protruding tap cannot be removed by the cutting device, then the Engineer shall be notified to determine if a point repair will be necessary. If the pipe in the vicinity of the protruding tap is in poor condition, the Contractor is to request authorization before proceeding with protruding tap removal.

Any damages caused to the sewer main or sewer service lateral during tap cutting shall be the responsibility of the Contractor and shall be repaired at no additional expense to the Owner, unless prior authorization has been given by the Engineer.

2. Payment:

Payment for the work included in this section shall be paid at the Contract Unit Price per each for Protruding Tap Removal.

END SECTION SP2

SP3: OPEN-CUT POINT REPAIRS

1. Description.

This work shall consist of the removal and replacement of portions of sanitary sewer pipe (sewer main and service lines) and all necessary removal and restoration of existing surface and utilities at locations show on the Plans. Work and materials incidental to OPEN-CUT POINT REPAIR may include, but are not limited to: excavation, shoring, sheeting, bracing, all pipes, fittings, adapters, pipe bedding, trench backfill, temporary aggregate, compaction, surface restoration (sidewalk, driveway pavement, lawns, etc.), bypass pumping and traffic control.

Site preparation including surface removal shall be as required for each individual point repair. The Contractor shall verify pipe size and type prior to construction.

2. Materials:

Pipes installed during point repairs shall conform to the following requirements and shall be free of visible cracks, holes, foreign material, blisters, or other deleterious faults.

2.1. PVC Sewer Pipe and Fittings:

- a. 8-inch to 12-inch diameter:
 - i. ASTM D3034- SDR 26
- b. Service pipes are to match sewer main.
- c. Fittings such as saddles, elbows, tees, and wyes shall be factory produced and have joint design compatible with adjacent pipe.
- d. Inserta Tee Fatboy, SDR 26, ASTM 3034 with rubber gasket and rubber sleeve ASTM F477.
- e. Transitions to existing pipe materials: Non-shear couplings with stainless band are required for connecting to existing sewer pipe and shall conform to ASTM C-1173. Gaskets shall conform to ASTM D5926. They shall be Fernco RC 5000 series shielded couplings or approved equal.
- f. Joints/Rubber Gasket: Conform to ASTM F477. Bell and spigot joint conforming to ASTM D3139, sealed by rubber gasket so assembly remains watertight under conditions of service including movements resulting from expansion, contraction, settlement, and deformation of pipe.
- g. Field applied heat fusion or solvent welded joints between pipe sections, pipe and fittings or fitting components shall not be permitted.
- h. Assembled joint shall pass performance tests as required in ASTM D3139.
- i. Pipe Markings:
 - i. Manufacturer's name or trademark.
 - ii. Nominal pipe size.
 - iii. PVC cell classification

- iv. ASTM D3034 SDR 26
- v. Extrusion date, period of manufacture or lot number.

3. Execution:

Replacement pipe shall be placed in the same line and grade of the existing pipe sections. The condition of the pipe sections upstream and downstream of the specified repair location shall be inspected and, if defective, the Engineer will determine if additional repairs are necessary. If additional pipe repairs of five feet or less are required, no additional compensation shall be made.

When specified repairs cannot be made because of physical limitations at the site, the Engineer shall be promptly notified. Alternate repair techniques shall be evaluated in cases where conventional repairs are not practical. Change orders may be required for alternate repairs. Sewer line repair pits shall remain uncovered until an inspection by the Engineer has been made.

- 3.1. Excavate repair pit and uncover the main line sewer a minimum of one-foot clearance all around at the damaged section, or as directed by the Engineer, and remove damaged pipe.
- 3.2. Dewatering shall be required so that excavations are kept free from water. Lay pipe only after trench is dewatered.
- 3.3. Defective pipe sections and service connections shall be removed by cutting the pipe past the bell end, if necessary, to allow for the use of rubber coupling. Replacement pipe lengths shall be cut to within one-fourth inch of the required replacement pipe length and attached to the existing pipe with appropriately sized rubber couplings. Defective service connections shall be replaced with appropriately sized wye connection and rubber couplings. Pipe bedding under the replacement pipe section shall be compacted to prevent settlement and provide support.
- 3.4. Where there is a sanitary service connection within the repair, it shall include up to five (5) feet of the service measured from the fitting. Connect ends of new service piping to existing piping using non-shear rubber mission coupling connectors. These connectors shall be designed to fit the new and existing pipes..
- 3.5. Replacement of sanitary service connections shall include the filling of any voids which may be found to exist around the lateral. The void space shall be filled with hydraulic cement or other approved material for a minimum distance of three feet.
- 3.6. Where the existing service lateral pipe is found to be in such a deteriorated condition that the specified reconnection cannot be made, the Engineer and City shall both be notified by the Contractor.
- 3.7. When multiple lateral services exist at an address, the Contractor shall determine if lateral is live. **Only live laterals are to be reconnected.** Dead laterals will be removed.
- 3.8. Seal joints within the repair pit that appear to be open or in poor condition, but the barrel of the pipe is still good. Roots in open joints shall be removed before sealing. All determinations for sealing joints shall be made by the Engineer. Joints that are open or in poor condition shall be cleaned and packed with a butyl rubber sealant and encased in quick setting, non-shrink concrete followed by encasement with concrete. The encasement shall be centered on the joint, have a minimum thickness of six inches, and have a minimum length equal to the pipe diameter but not less than twelve inches. Methods for sealing open joints other than that described above shall be submitted to the Engineer for approval.
- 3.9. Backfill point repair in accordance with standard details and specifications.

4. Backfilling:

The bedding, haunching and backfilling for pipe installation shall be as shown on the standard details and as specified in Section D2-10 of the standard specifications except as modified in these Special Provisions.

5. Pipe Bedding:

The Contractor shall furnish, place, compact and transport coarse aggregate gradation CA-7 or CA-11 for pipe bedding to a minimum depth of 4" below the bell of the pipe and 12" above the bell of the pipe. Pipe bedding under the replacement pipe section shall be compacted to prevent settlement and provide support.

6. Excavated Material Backfill:

Backfill with excavated material from trenches, unless granular material backfill is required as specified below. Excavated material shall consist of loam, clay or other materials, which, in judgment of Engineer, are suitable for backfilling. Unsuitable backfill materials are not acceptable. Extend backfill from surface of cover material to ground surface, making allowance for surface restoration.

The Contractor shall maintain trenches flush with existing surfaces until permanent patches are installed or site restoration is completed. No additional compensation will be provided to the Contractor for trench maintenance.

For all other areas not adjacent to pavement, excavated earth free from organic materials shall be used. Costs associated with earthen backfill shall be considered incidental to each Point Repair.

The Contractor shall also place granular material backfill within influence zone under new or existing roads, sidewalks, paved surface, driveways, or foundations and footings. Extend backfill from surface of cover material to top of existing pavement structure to allow backfill to function as temporary aggregate roadway. The Contractor shall replace backfill displaced by traffic movement as necessary until temporary bituminous pavement or permanent pavement is installed at no additional cost to the Owner.

7. Placing Backfill:

The Contractor shall not use frozen material for backfill or place backfill on frozen sub-grade. Care shall be taken to not exert undue stresses on new piping or existing utilities when dumping, spreading, and/or compacting backfill materials. Hand spreading and hand tamping may be required to adequately protect new pipe and existing utilities.

Where pipes leave structures, protect by backfilling pipe influence zone down to undisturbed soil as specified above for support of underground structure. Do not backfill structures until new concrete has properly cured.

8. Compaction of Backfill:

The trench backfill shall be compacted only as defined in Section D2-10 of these specifications.

The standard test to define maximum densities of all compaction work shall be ASTM D-1557. All densities shall be expressed as a percentage of the maximum density obtained in the laboratory by the ASTM D-1557 standard procedure. Each layer shall be compacted by mechanical means to 95 percent of the maximum dry density.

The Contractor shall start trench compaction at the point of lowest elevation of trench and work along the complete length of the trench. Backfill shall be placed around the pipe immediately after installation and inspection unless delay is approved by the Engineer.

The select granular backfill material shall be placed and compacted in 12-inch maximum layers of the specified materials as shown on the Drawings and installed from the top of bedding to the existing finished grade. Care shall be taken during compaction to prevent disturbance or injury of the pipe and other utilities.

9. Post-construction television inspection for sewer repairs:

Post-construction internal television inspection shall be conducted on all sewers receiving sewer repairs. This inspection shall be per NASSCO standards by PACP certified operators. Digital video inspections of the post-rehabilitation television inspection for each sewer section shall be provided to the Engineer and the Owner as described below:

After the work is completed, the Contractor shall provide to the Owner two (2) flash drives containing each video file and associated PDF report, which shall document, to the satisfaction of the Engineer, the condition of the sewer repairs immediately after rehabilitation and that it has been installed correctly and that all of the active connections have been restored. Post-construction television inspection and all deliverables shall be considered incidental to this pay item.

10. Other Incidental items:

Surface restoration, bypass pumping, protection of overhead wires and utility poles, bracing of utility poles or other utilities, traffic control, coordination with homeowners and home association and all other work associated with completing the point repair shall be considered incidental to this cost item.

11. Basis of Payment.

This work shall be paid at the Contract Unit Price per Lump Sum for each individual POINT REPAIR of the name, pipe diameter, length and type of restoration specified.

END SECTION SP3

SP4: LATERAL REINSTATEMENTS

After the cured-in-place pipe has been cured, the Contractor shall reconnect the existing active branch or service lines as designated by the City. This shall be done without excavation and in the case of non-man entry pipes, from the interior of the pipelines by means of a television camera and a remote cutting device that re-establishes them to not less than 90 percent capacity and not more than 100% of the internal diameter of the lateral pipe. The surface of the opening shall be wire brushed to remove extraneous material and provide a smooth edge at each lateral connection.

1. Contractor shall reinstate all laterals that are connected directly to the rehabilitated sewer main after the rehabilitation of each sewer is completed using robotic cutting equipment
2. Reinstatement using open-cut excavation shall not be allowed.
3. Reinstatement of laterals shall be as recommended by the liner manufacturer.
4. All cut edges at the reinstated laterals shall be smooth and free of jagged edges that can hang up solids and shall not be cut to expose host pipe.
5. Any over-cut lateral openings that exposes the host pipe shall be sealed, as recommended by the liner manufacturer, and approved by the Engineer, as deemed necessary by the Engineer.
6. The connection between the lateral and the rehabilitated sewer main shall not restrict flow from the lateral into the rehabilitated lateral.
7. Any lateral reinstatement that has jagged edges or impedes the flow from the lateral shall be considered defective and shall be re-cut until approved by the Engineer.
8. Reinstatement of the laterals shall be performed in the presence of the Engineer.
9. Reinstatement of laterals shall be performed immediately (within 4 hours) after approval of lining by the Engineer and all connections shall be sealed as directed by Engineer.
10. Each reinstated lateral shall be air tested and grouted. This work shall be performed for as described under the provision SP5: AIR TEST AND GROUT SERVICE CONNECTIONS.
11. Basis of Payment.

This work shall be paid at the Contract Unit Price per Each for Lateral Reinstatements.

END SECTION SP4

SP5: AIR TEST AND GROUT SERVICE CONNECTIONS

General. This work shall consist of testing and grouting of sanitary service connections. Locations for service connection grouting shall be identified by pressure testing all service lateral connections and then sealing the lateral connections that fail the pressure test. Locations selected shall be approved by the Engineer in advance of performing any service lateral grouting. All grouting of service laterals shall be completed prior to the final post televising of the sewer segment.

Execution: For each service lateral reinstated within the project, the Contractor shall pressure test the service lateral connection and seal the failed lateral connections. For factory tees and wyes, the test and seal shall include the first joint upstream of the mainline sewer, including a minimum distance of five (5) feet from the main. For break-in connections, the test and seal shall include the break-in and the first joint upstream of the mainline sewer, also including a minimum distance of five (5) feet from the connection to the main.

The Contractor shall apply air pressure of 0.5 psig per vertical foot of sewer depth plus an additional 2.0 psig (total pressure not exceeding 10 psig). The test pressure and pipeline depth shall be recorded. If the air pressure on the lateral connection drops 1.0 psig within a 15-second time period, the connection “fails” the test and requires sealing as specified herein.

The Contractor will be required to retest failed connections after the sealing procedure is completed to verify effectiveness of the sealing. This shall be done by first deflating the packer ends until the “void” pressure meter reads zero pressure. The Contractor shall clean the equipment of residual grout. Once equipment is clean the Contractor shall re-inflate the packer ends and apply test pressure again. Grouted connections failing the pressure test shall be resealed and retested until each connection passes the air test.

Complete records shall be kept of lateral connections sealing performed in each sewer section. The records shall identify the manhole to manhole section in which the testing and sealing was done, the location and type of each lateral connection tested and/or sealed, whether there is visible evidence of infiltration and inflow at each service connection and an estimated flow rate in gallons per minute, any problems with the service connection i.e. roots, grease, etc., the test pressure before and after sealing, the quantity of chemical sealing material used at each lateral connection in gallons, the chemical set time and materials including any additives, and the lateral connection sealing verification results. PDF reports for each sewer segment tested and sealed shall be included on the final hard-drive deliverable.

The Contractor shall be required at a minimum, to apply one gallon of grout per foot of sealing distance for each lateral connection. During grouting operations, the Contractor shall televise the lateral connection testing and sealing and provide one digital video file for each sewer section containing service lateral testing/sealing. This digital video file is to be included on the final hard-drive deliverable and shall be linked into the Master excel spreadsheet.

Any excess grout that remains in the sewer main shall be removed by the Contractor. The Contractor shall perform an air test on the service lateral and/or flush test from the residence to confirm that the service lateral is open for sewerage flow. The Contractor shall be solely responsible and liable for any property damages resulting from the grouting work.

Post-construction inspection. All pipe sections shall be final inspected by means of a color CCTV system. The inspection shall be conducted as per the NASSCO Pipeline Assessment and Certification Program (PACP). Post-construction televising shall be performed after all rehabilitation work is completed and as described under Section D2-12A Post-Rehabilitation Sanitary Sewer CCTV Inspection.

Basis of Payment. This work shall be incidental to lateral reinstatement at the Contract Unit Price per Each for Lateral Reinstatements, per each service connection reinstated, tested and per each service connection chemically sealed, after CIPP lining of a sanitary sewer segment. No additional payment will be made for air testing, catalyst, activator, inhibitor, buffer, root control, or additive materials required to obtain the final product in place

END SECTION SP5

**CONSTRUCTION PLANS FOR
OPEN-CUT REPLACEMENT OF
SEGMENT MH174:MH133**

LEGEND:

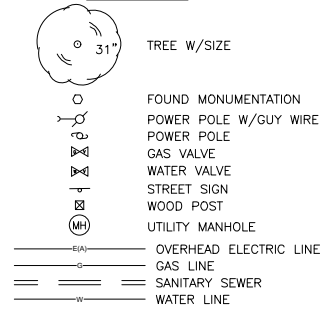

CONSTRUCTION PLANS FOR REMOVAL & REPLACEMENT OF SEGMENT BETWEEN MH174:MH133 (SANITARY SEWER REHABILITATION PROJECT - PHASE I)

CITY OF MASCOUTAH,
ILLINOIS

ENGINEERING DEPARTMENT

INDEX OF DRAWINGS

SHT. NO.	DESCRIPTION
1	COVER SHEET
PP-1	PLAN & PROFILE - SEGMENT MG174:MH133
PR-1	PAVEMENT REPAIR PLAN
D1-D3	MISCELLANEOUS DETAILS

ABBREVIATIONS

N	NORTH
S	SOUTH
E	EAST
W	WEST
CONC	CONCRETE
ASPH	ASPHALT
PVMT	PAVEMENT
W/	DENOTES WITH
BK	BOOK
PG	PAGE
FL	FLOWLINE
VCP	VITRIFIED CLAY PIPE
WMH	WATER MANHOLE
CO	CLEANOUT
EM	ELECTRIC METER
WSO	WATER SHUT OFF
#	NUMBER

PREPARED BY

rjngroup

CONSULTING ENGINEERS
2000 SOUTH EIGHTH ST.
ST. LOUIS, MISSOURI 63104
(314) 588-9764

UTILITY CONTACTS

Ameren (Gas) Illinois P.O. Box 66884 St. Louis, Mo. 63166-6884 Phone: 1-888-659-4540	City Of Mascoutah, Electric 3 W. Main Street Mascoutah, Mo. 62258 Phone: 618-566-2964
City Of Mascoutah, Water 3 W. Main Street Mascoutah, Illinois 62258 Phone: 618-566-2964	Charter Communications 3950 Green Mount Crossing Dr Shiloh, IL Phone: 1-888-406-7063
City Of Mascoutah, City Hall 3 W. Main Street Mascoutah, Illinois 62258 Phone: 618-566-2964	Illinois Dept. of Transportation District 8 1102 Eastport Plaza Dr. Collinsville, Illinois 62234 Phone: 618-346-3203
City Of Mascoutah, Sewer 3 W. Main Street Mascoutah, Illinois 62258 Phone: 618-566-2964	



APPROVED BY:

Thomas J. [Signature]

CITY ENGINEER

12/14/2020

DATE

ENGINEER'S CERTIFICATION:



PROJECT MANAGER

12/14/2020

DATE

FOR UNDERGROUND UTILITY LOCATIONS CALL
J.U.L.I.E. 1-800-892-0123

MASCOUTAH SANITARY SEWER REHABILITATION PHASE I

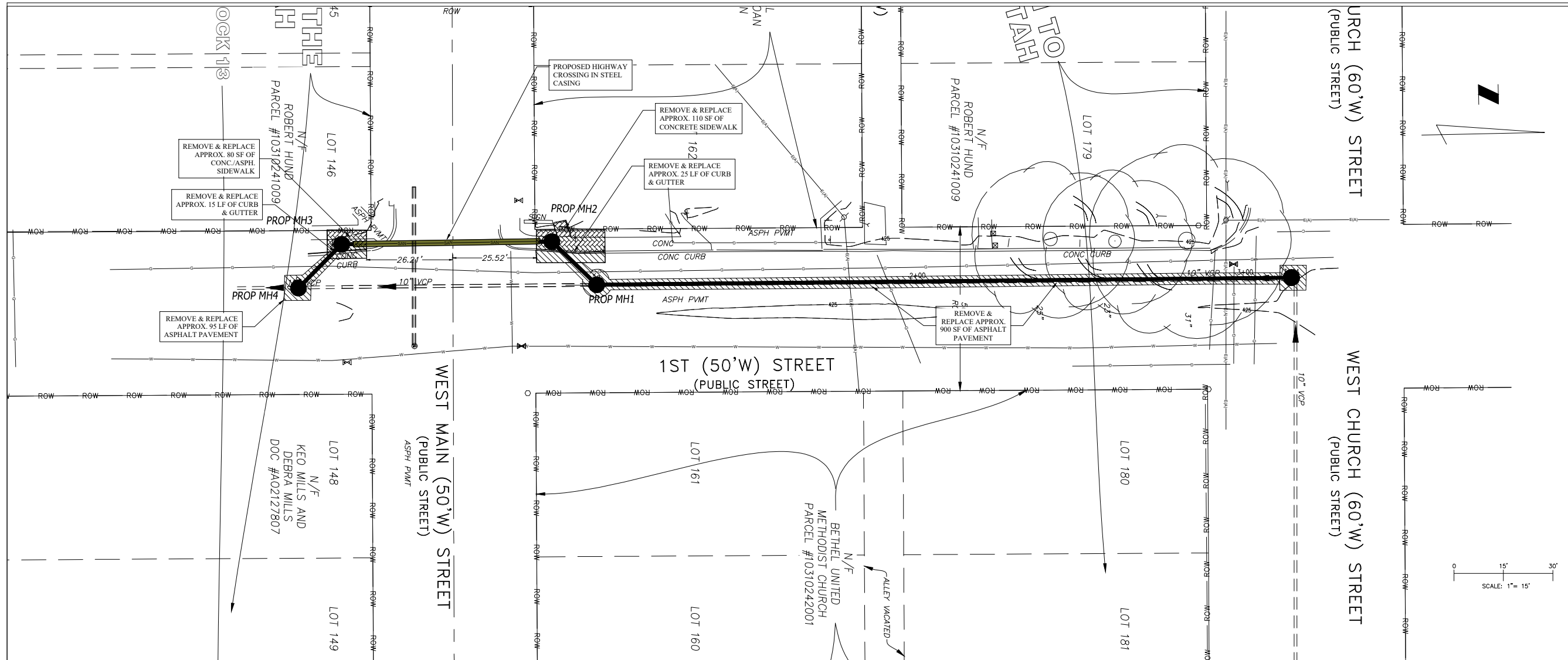

PLAN

- NOTES:**
1. CITY OF MASCOUTAH INSPECTION SPECIFIC REQUIREMENTS SHALL BE DISCUSSED WITH THE OWNER. NO WORK IN AREAS REQUIRING CITY INSPECTION SHALL BEGIN UNTIL THESE REQUIREMENTS HAVE BEEN COMMUNICATED.
 2. CONTRACTOR SHALL PROVIDE THE CITY WITH A TRAFFIC CONTROL PLAN PRIOR TO THE START OF CONSTRUCTION. TRAFFIC FLOW SHALL BE MAINTAINED THROUGH WEST CHURCH & 1ST ST. AT ALL TIMES.
 3. CONTRACTOR SHALL COORDINATE WITH HOMEOWNERS/BUSINESS OWNERS TO ALLOW ACCESS TO DRIVEWAYS DURING CONSTRUCTION.

4. ALL REPAIRS/REPLACEMENTS FOR ROADWAY/RAMPS/CURBS/DRIVEWAYS SHALL CONFORM TO THE PROVIDED DETAILS AND SPECIFICATIONS. NO SEPARATE PAYMENT WILL BE MADE FOR THIS WORK.
5. CONTRACTOR SHALL RESTORE THE SURFACES BACK TO ITS ORIGINAL STATE AFTER COMPLETION OF WORK.
6. CONTRACTOR SHALL SAWCUT 2' FROM THE BACK OF THE CURB IN ORDER TO PRESERVE CURBS AND DRIVEWAYS WHERE APPLICABLE.
7. CONTRACTOR SHALL INSTALL EROSION CONTROL DEVICES ALONG EXCAVATED AREAS AS REQUIRED CONFORMING SPECIFICATIONS AND DETAILS PROVIDED.

LEGEND

	REMOVE & REPLACE CONCRETE SIDEWALK
	REMOVE & REPLACE ASPHALT PAVEMENT

DRAWN BY: B.K.A.	CHECKED BY: N.C.
OWNER CITY OF MASCOUTAH 3 WEST MAIN ST. MASCOUTAH, IL 62258 PHONE 618-566-2964	
PROJECT MASCOUTAH SANITARY SEWER REHABILITATION PHASE I, SEGMENT MH 174; MH 133 REPLACEMENT RJN PROJECT NO 15-3519-00 ST. CLAIR COUNTY, ILLINOIS	
TITLE 10" SANITARY SEWER REPLACEMENT PAVEMENT REPAIR PLAN	
Project No 15-3519-000	Sheet No PR-1
Date 12/14/2020	

Path: \\SI-panzura\office-15\ST. LOUIS\002 - PROJECTS\15-3519-00 Mascoutah Sanitary Sewer Rehab Phase 1\8.0 Design\ Plotted on: 12/10/20 @ 07:08:11PM by bakaya

THE PROFESSIONAL WHOSE SIGNATURE AND PERSONAL SEAL APPEAR HEREON, ASSUMES RESPONSIBILITY ONLY FOR WHAT APPEARS ON THIS PAGE, AND DISCLAIMS (PURSUANT TO SECTION 327.411 RSMC) ANY RESPONSIBILITY FOR ALL OTHER PLANS, SPECIFICATIONS, ESTIMATES, REPORTS, OR OTHER DOCUMENTS OR INSTRUMENTS NOT SEALED BY THE UNDERSIGNED PROFESSIONAL RELATING TO OR INTENDED TO BE USED FOR ANY PART OR PARTS OF THE PROJECT TO WHICH THIS PAGE REFERS.

NOTE:
PROJECT MANUAL REFERS TO "PROJECT SPECIFICATIONS"

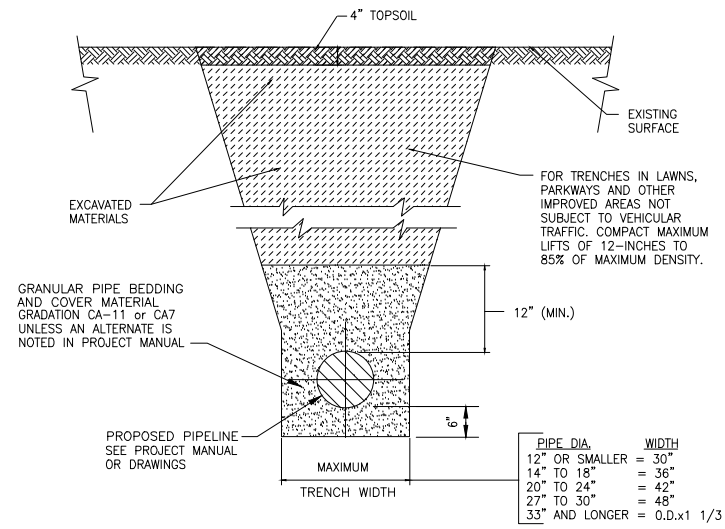

TYPICAL TRENCH DETAIL
(FOR NON-PAVED AREAS)

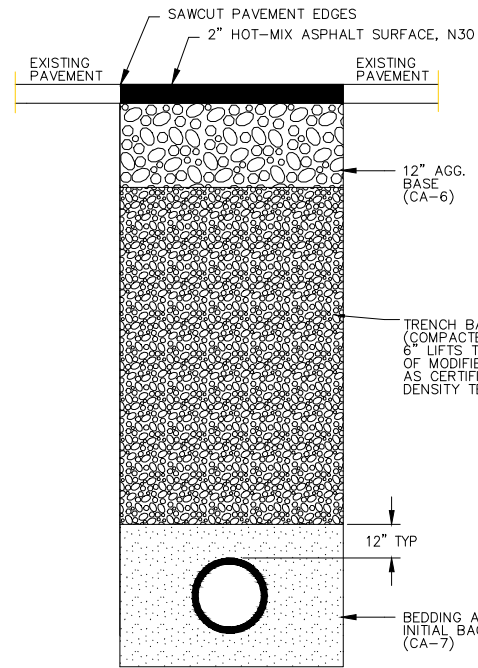

OPEN CUT TEMPORARY STREET RESTORATION
(TEMPORARY PATCH, 2")

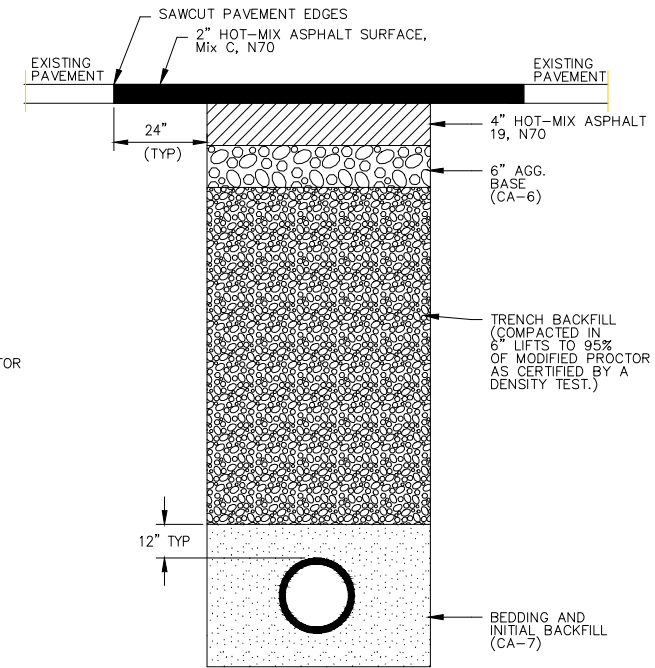

OPEN CUT FINAL STREET RESTORATION
(CLASS D PATCH, 4")

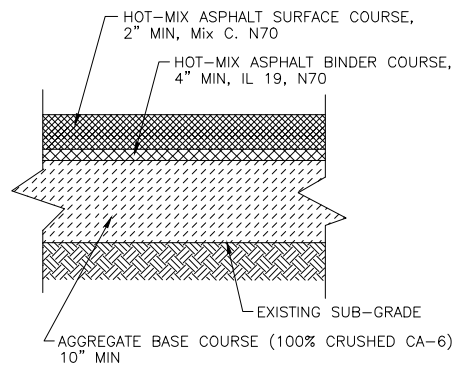

- NOTES:
1. THIS DETAIL IS FOR REMOVE AND REPLACE SANITARY SEWER AND HMA PAVEMENT REMOVAL AND REPLACEMENT.
 2. IF PAVEMENT IS GREATER THAN 6" THICKNESS, MATCH EXISTING PAVEMENT THICKNESS.
 3. PRIOR TO THE CONSTRUCTION OF ROADWAY PAVEMENT ALL OF THE UNDERGROUND WORK SHALL BE COMPLETELY INSTALLED IN PLACE AND APPROVED.
 4. ALL TRENCHES WHICH ARE UNDER PROPOSED ROADWAY AND CURB SHALL BE BACKFILLED UNDER AND TWO (2) FEET BEYOND ROADWAY AND CURB WITH GRANULAR MATERIALS (IDOT CA-6 OR APPROVED MATERIALS), COMPACTED IN AN APPROVED MANNER TO NOT LESS THAN NINETY-FIVE (95%) STANDARD PROCTOR DENSITY.
 5. THE ROADWAY SUBGRADE SHALL BE SHAPED AND COMPACTED AS SPECIFIED IN ACCORDANCE WITH IDOT STANDARD SPECIFICATIONS, SECTION 212. JUST PRIOR TO CONSTRUCTION OF THE AGGREGATE BASE COURSE THE SUBGRADE SHALL BE PROOF ROLLED AND WITNESSED BY THE ENGINEER FOR THE OWNER. IF IN THE OPINION OF THE ENGINEER ANY AREAS OF THE SUBGRADE ARE FOUND UNSUITABLE, THESE AREAS SHALL BE REMOVED AND REPLACED WITH GRANULAR MATERIALS (IDOT CA-1 OR APPROVED MATERIALS) IN ADDITION TO A LAYER OF GEOTEXTILE ROAD FABRIC.

PAVEMENT PATCHING

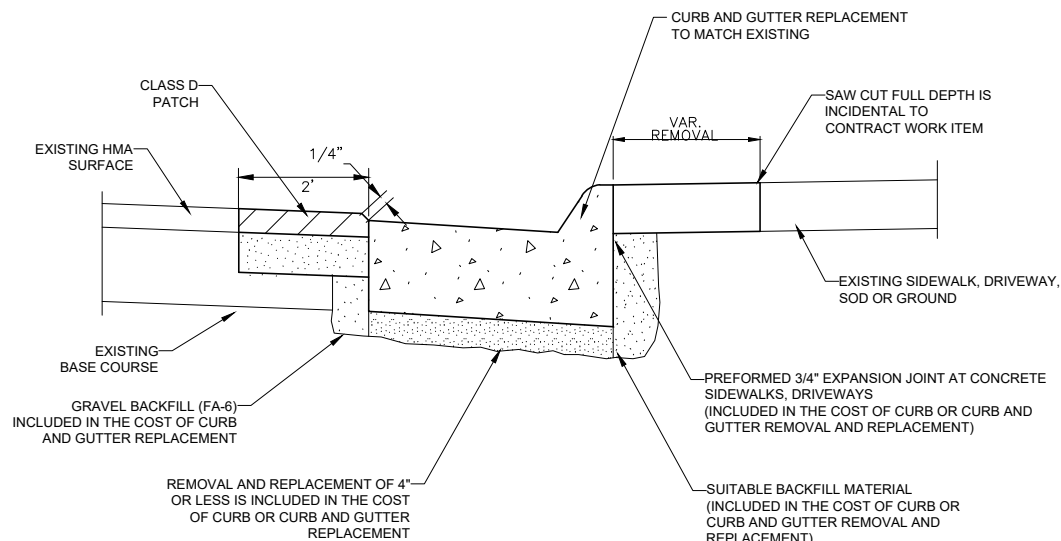

CURB AND GUTTER REMOVAL AND REPLACEMENT

BASIS OF PAYMENT:
THIS WORK WILL NOT BE PAID FOR SEPARATELY AND WILL BE INCIDENTAL TO OPEN-CUT REPLACEMENT OF SEGMENT MH174; MH133

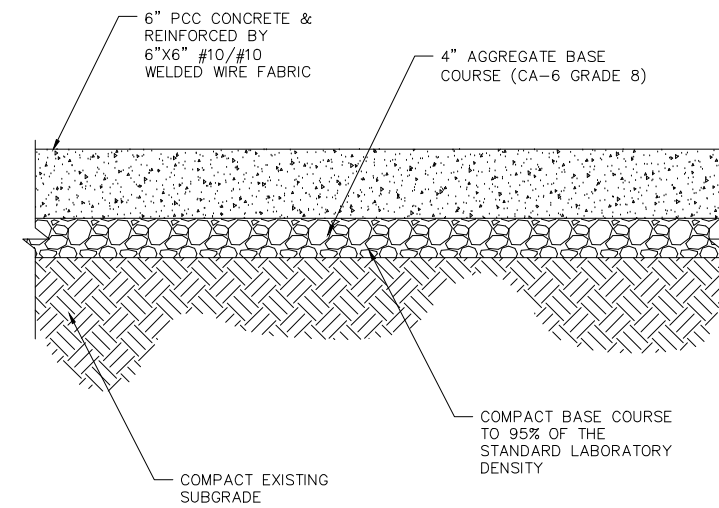

PCC DRIVEWAY REPLACEMENT

NOT TO SCALE

2000 S. 8th Street
St. Louis, MO 63104
(314) 988-9764
www.rjngroup.com

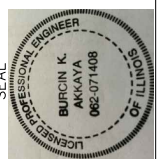

SEAL
DRAWN BY: B.K.A.
CHECKED BY: N.G.

CITY OF MASCOUTAH
3 WEST MAIN ST.
MASCOUTAH, IL 62258
PHONE 618-566-2964

OWNER
PROJECT
MASCOUTAH SANITARY SEWER
REHABILITATION PHASE I,
SEGMENT MH 174; MH 133 REPLACEMENT
R/N PROJECT NO 15-3519-00
ST. CLAIR COUNTY, ILLINOIS

TITLE
MISCELLANEOUS DETAILS

Project No 15-3519-00
Date
12/14/2020
Sheet No D-1

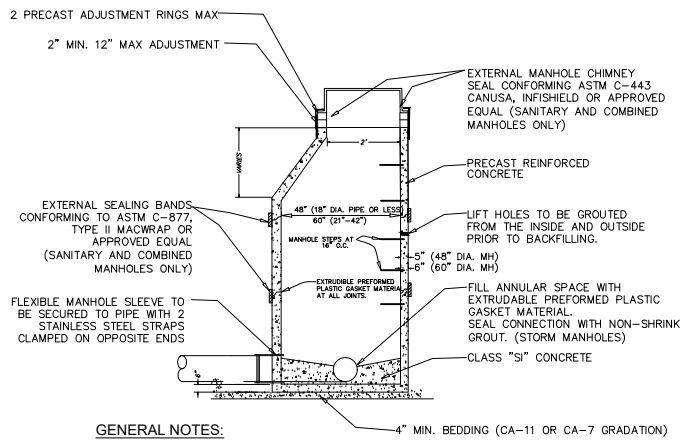

GENERAL NOTES:

1. FRAME AND LID (SANITARY):
NEENAH R-1772, TYPE "B" SELF SEALING LID
OR E.J.W 1022-1 HD
2. FRAME AND LID (STORM):
NEENAH R-1015-2000 FRAME
NEENAH R-1015-2001 LID
3. ALL LIFT HOLES ARE TO BE GROUTED
FROM INSIDE AND OUTSIDE BEFORE
BACKFILLING

STANDARD MANHOLE
NOT TO SCALE

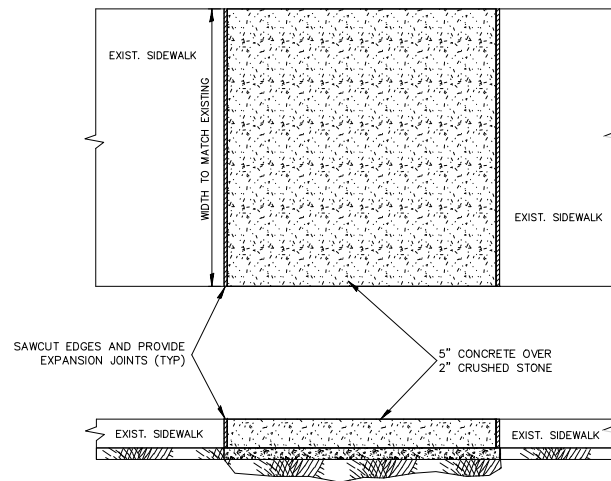

SIDEWALK RESTORATION

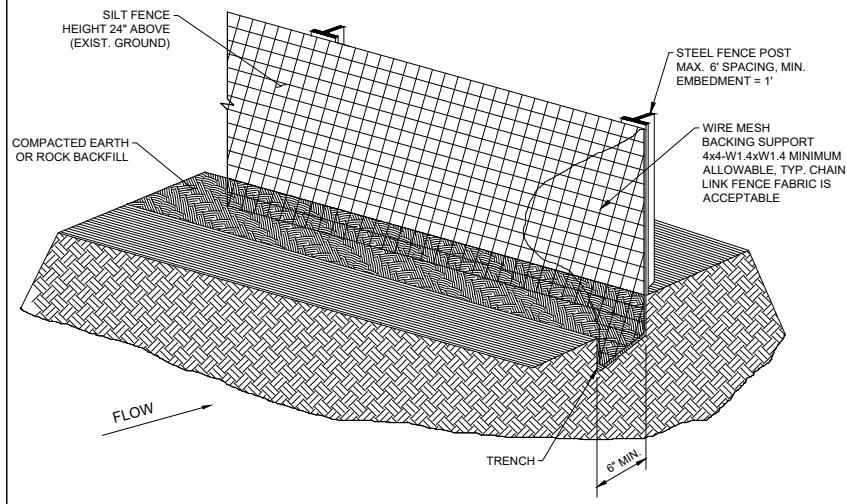

SILT FENCE ISOMETRIC
PLAN VIEW
NOT TO SCALE

SILT FENCE GENERAL NOTES:

1. STEEL POSTS WHICH SUPPORT THE SILT FENCE SHALL BE INSTALLED ON A SLIGHT ANGLE TOWARD THE ANTICIPATED RUNOFF SOURCE. POST MUST BE EMBEDDED A MINIMUM OF ONE FOOT.
2. THE TOE OF THE SILT FENCE SHALL BE TRENCHED IN WITH A SPADE OR MECHANICAL TRENCHER, SO THAT THE DOWN SLOPE FACE OF THE TRENCH IS FLAT AND PERPENDICULAR TO THE LINE OF FLOW. WHERE FENCE CANNOT BE TRENCHED IN (E.G. PAVEMENT), WEIGHT FABRIC FLAP WITH ROCK ON UPHILL SIDE TO PREVENT FLOW FROM SEEPING UNDER FENCE.
3. THE TRENCH MUST BE A MINIMUM OF 6 INCHES DEEP AND 6 INCHES WIDE TO ALLOW FOR THE SILT FENCE FABRIC TO BE LAID IN THE GROUND AND BACKFILLED WITH COMPACTED MATERIAL.
4. SILT FENCE SHOULD BE SECURELY FASTENED TO EACH STEEL SUPPORT POST OR TO WOVEN WIRE, WHICH IN TURN IS ATTACHED TO THE STEEL FENCE POST. THERE SHALL BE A 3 FOOT OVERLAP. SECURELY FASTENED WHERE ENDS OF FABRIC MEET.
5. INSPECTION SHALL BE MADE EVERY TWO WEEKS AND AFTER EACH 1/2\"/>

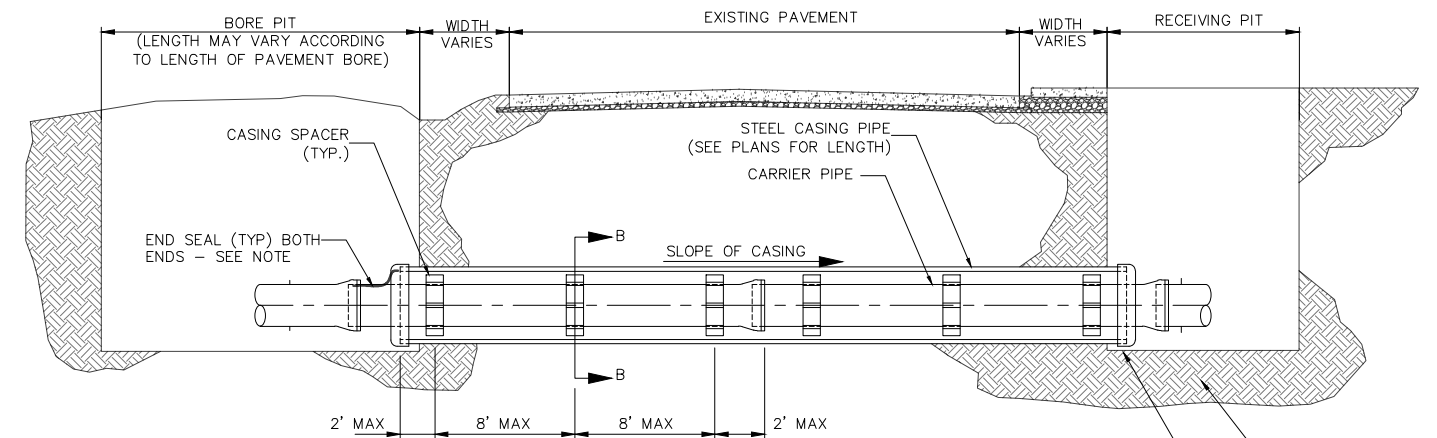

NOTE:

1. INSTALLATION OF THE CASING AND CARRIER PIPES SHALL MEET THE REQUIREMENTS OF PROJECT SPECIFICATIONS.
2. CASING PIPES FOR ROAD AND HIGHWAY CROSSINGS SHALL BE WELDED STEEL PIPE WITH A MINIMUM WALL THICKNESS AND MINIMUM DIAMETER AS STATED IN THE RELATED SPECIFICATIONS.

HIGHWAY CROSSING
JACK AND BORE
NOT TO SCALE

NOTE:

- BOTH ENDS OF THE CASING BETWEEN THE CASING AND CARRIER PIPE SHALL BE SEALED USING AN END SEAL.
- VOIDS BETWEEN CASING AND CARRIER PIPE SHALL BE FILLED WITH 1:7 GROUT INCLUDING 5%-40% AIR ENTRAINMENT BY PRESSURE INJECTION.

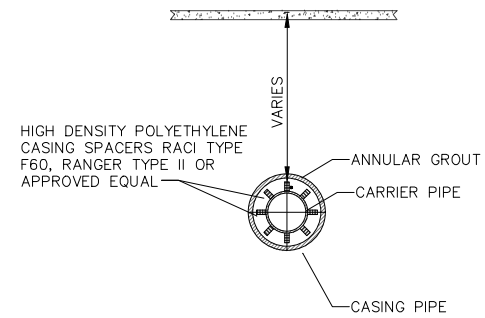

SECTION B-B
NOT TO SCALE

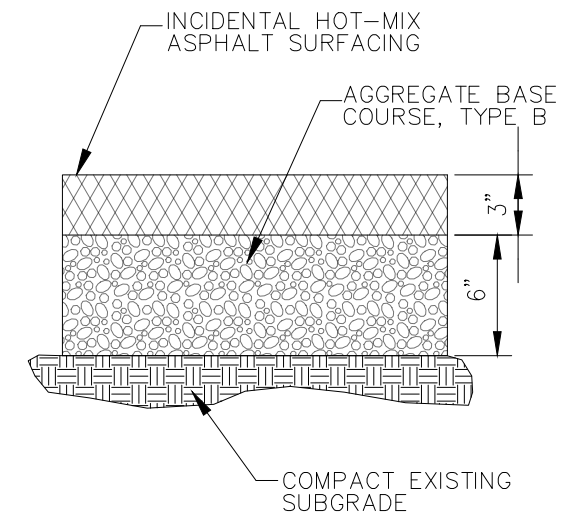

BITUMINIOUS DRIVEWAY REPLACEMENT
NOT TO SCALE

2000 S. 8th Street
St. Louis, MO 63104
(314) 598-9764
www.rjngroup.com



SEAL
DRAWN BY: B.A.A.
CHECKED BY: N.C.

CITY OF MASCOUITAH
3 WEST MAIN ST.
MASCOUITAH, IL 62258
PHONE 618-566-2964

OWNER
PROJECT
MASCOUITAH SANITARY SEWER
REHABILITATION PHASE I,
SEGMENT MH 174; MH 133 REPLACEMENT
RJN PROJECT NO 15-3519-00
ST. CLAIR COUNTY, ILLINOIS

TITLE
MISCELLANEOUS DETAILS

Project No
15-3519-000
Date
12/14/2020
Sheet No
D-2

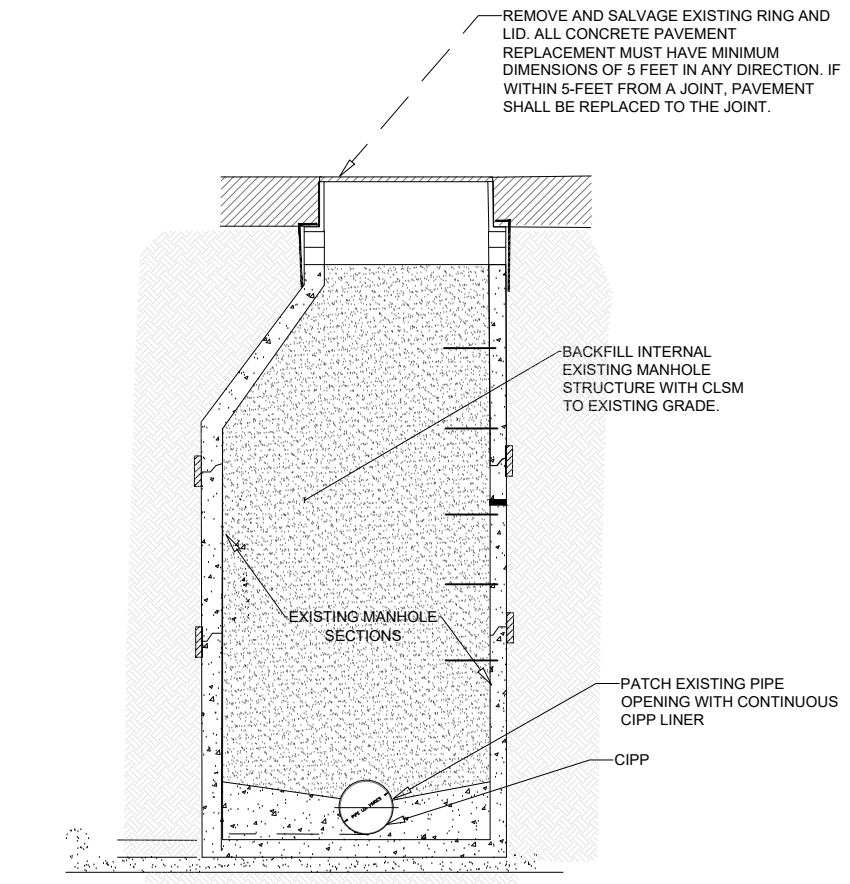

STANDARD MANHOLE
DECOMMISSION DETAIL (PAVED SURFACE)
NOT TO SCALE

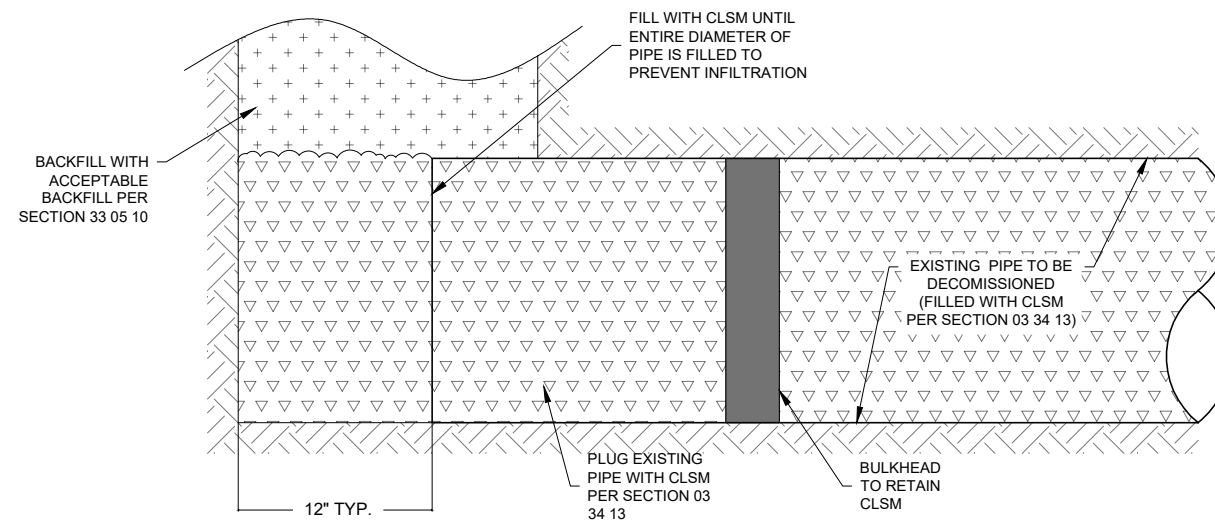

PIPE ABANDONMENT
IN PLACE
NOT TO SCALE

2000 S. 8th Street
St. Louis, MO 63104
(314) 598-9764
www.rjngroup.com



SEAL
BURCIN K. AKKAYA
082-071408
STATE OF ILLINOIS
LICENSED PROFESSIONAL ENGINEER

DRAWN BY:
B.K.A.
CHECKED BY:
N.G.

OWNER
CITY OF MASCOUTAH
3 WEST MAIN ST.
MASCOUTAH, IL 62258
PHONE 618-566-2964

PROJECT
MASCOUTAH SANITARY SEWER
REHABILITATION PHASE I,
SEGMENT MH 174; MH 133 REPLACEMENT
R/JN PROJECT NO 15-3519-00
ST. CLAIR COUNTY, ILLINOIS

TITLE
MISCELLANEOUS DETAILS

Project No	Sheet No
15-3519-000	D-3
Date	
12/14/2020	

**REHABILITATION SCHEDULES &
EXHIBITS**

NOTE:
1. All utility locations are approximate and Contractor is responsible for utility locates.
2. Contractor shall protect all underground and overhead utilities. Any damage caused will be responsibility of Contractor
3. Surface disturbed by construction activities as shown on this exhibit shall be restored to its pre-construction state.
4. Field verify all pipe sizes and material.

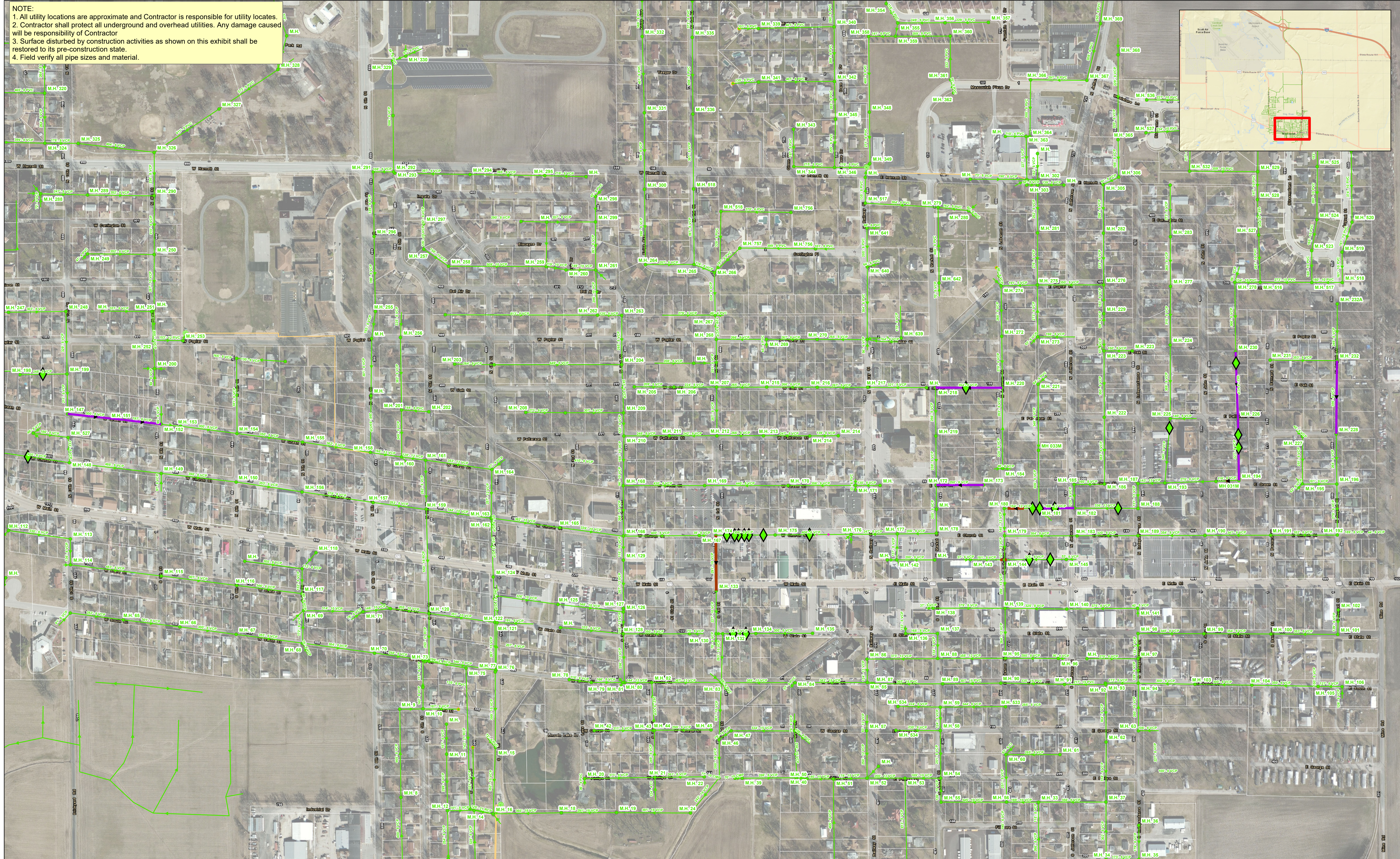
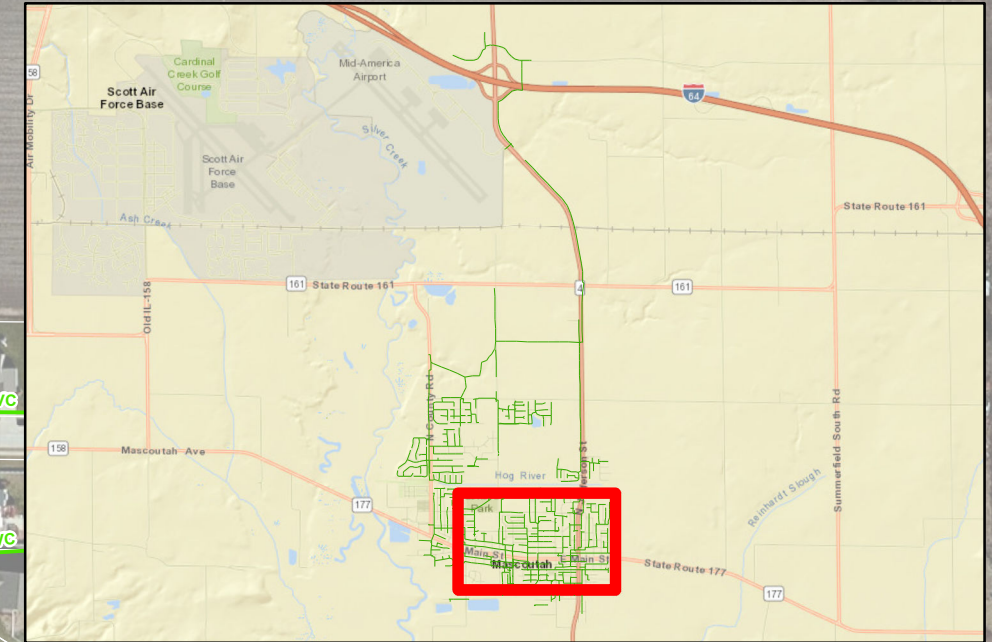

City of Mascoutah, IL
Overall Proposed
Rehabilitation Map
Sanitary Sewer Rehabilitation Phase I
August 2020

- Utilities Legend**
- Sewer Manholes
- ssGravityMain
- ◆ Open Cut Lateral Repair Location
- Open Cut Segment Repair Location
- Point Repair
- High Lining Priority

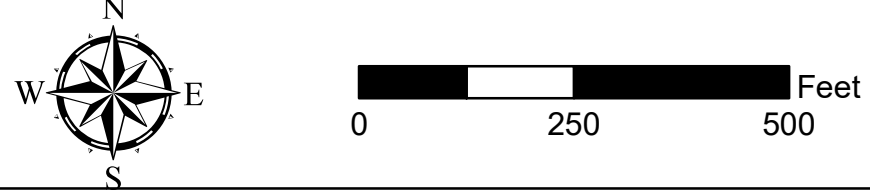

CITY OF MASCOUTAH
2020 SANITARY SEWER REHABILITATION PHASE I
OPEN-CUT REPAIR SCHEDULE FOR LATERALS AND SEGMENTS

USMH	DSMH	Segment Length (ft)	Approximate Address	Repair Location	Repair Type	Repair Length	Number of Live Services Within Opencut Repair	Surface Type	Property Owner
MH528	MH148	455	1014 W. Church St.	238.7' from US Manhole	Dropped Lateral	NA	NA	Asphalt Driveway	
MH198	MH199	249	Behind 1098 W. Green St.	126.8' from US Manhole	Broken Lateral	NA	NA	Grass Easement	City of Mascoutah
MH230	MH226	352	Between N. John&N. Bernard, from E. Oak to E. Patterson	61.4' from US Manhole	Dropped Lateral	NA	NA	Grass Easement	City of Mascoutah
MH225	MH193	340	415 E. Patterson St.	49.6' from US Manhole	Broken Lateral	NA	NA	Grass Easement	City of Mascoutah
MH226	MH194	325	Alley between N. John&N. Bernard, from E. Green to E. Patterson	154.4' from US Manhole	Broken Lateral	NA	NA	Chipseal	City of Mascoutah
MH226	MH194	325	Alley between N. John&N. Bernard, from E. Green to E. Patterson	86.6' from US Manhole	Dropped Lateral	NA	NA	Chipseal	City of Mascoutah
MH188	MH182	337	Alley between E. Church & E. Green, from N. Independence to N. Jefferson	99.5' from US Manhole	Broken Lateral	NA	NA	Gravel Alley	City of Mascoutah
MH182	MH181	188	Alley between E. Church & E. Green, from N. Jefferson to N. Lebanon	97.8' from US Manhole	Dropped Lateral	NA	NA	Gravel Alley	City of Mascoutah
MH182	MH181	188	Alley between E. Church & E. Green, from N. Jefferson to N. Lebanon	177.2' from US Manhole	Broken Lateral	NA	NA	Gravel Alley	City of Mascoutah
MH181	MH180	185	Alley between E. Church & E. Green, from N. Jefferson to N. Lebanon	34.9' from US Manhole	Broken Lateral	NA	NA	Gravel Alley	City of Mascoutah
MH220	MH218	355	199 E. Oak St.	188.4' from US Manhole	Broken Lateral	NA	NA	Asphalt Pavement	City of Mascoutah
MH145	MH144	314	Alley between E. Church & E. Main St, from N. Jefferson to N. Lebanon	177.7' from US Manhole	Broken Lateral	NA	NA	Chipseal	City of Mascoutah
MH145	MH144	314	Alley between E. Church & E. Main St, from N. Jefferson to N. Lebanon	67.7' from US Manhole	Broken Lateral	NA	NA	Chipseal	City of Mascoutah
MH134	MH132	177	57 W. State St.	48.9' from US Manhole	Dropped Lateral	NA	NA	Asphalt Pavement	City of Mascoutah
MH134	MH132	177	58 W State St.	116.1' from US Manhole	Dropped Lateral	NA	NA	Asphalt Pavement	City of Mascoutah
MH175	MH174	312	40 W. Church St.	49.2' from US Manhole	Dropped Lateral		NA	Asphalt Pavement	City of Mascoutah

CITY OF MASCOUTAH
2020 SANITARY SEWER REHABILITATION PHASE I
OPEN-CUT REPAIR SCHEDULE FOR LATERALS AND SEGMENTS

USMH	DSMH	Segment Length (ft)	Approximate Address	Repair Location	Repair Type	Repair Length	Number of Live Services Within Opencut Repair	Surface Type	Property Owner
MH175	MH174	312	48 W. Church St.	125.4' from US Manhole	Large Offset Connection (Lateral to main connection)	NA	NA	Asphalt Pavement	City of Mascoutah
MH175	MH174	312	52 W. Church St.	149.8' from US Manhole	Large Offset Connection (Lateral to main connection)	NA	NA	Asphalt Pavement	City of Mascoutah
MH175	MH174	312	52 W. Church St.	180.2' from US Manhole	Large Offset Connection (Lateral to main connection)	NA	NA	Asphalt Pavement	City of Mascoutah
MH175	MH174	312	55 W. Church St.	201.4' from US Manhole	Large Offset Connection (Lateral to main connection)	NA	NA	Asphalt Pavement	City of Mascoutah
MH175	MH174	312	55 W. Church St.	241' from US Manhole	Large Offset Connection (Lateral to main connection)	NA	NA	Asphalt Pavement	City of Mascoutah
MH176	MH175	405	33 W. Church St.	Starts at 210.9' from US Manhole	Large Offset Connection (Lateral to main connection)	NA	NA	Asphalt Pavement	City of Mascoutah
MH181	MH180	185	Alley between E. Church & E. Green, from N. Jefferson to N. Lebanon	Starts at 80' from US Manhole	Collapsed Pipe	Unknown	Unknown	Gravel Alley	City of Mascoutah
MH033M	MH181	322	Behind 205 E. Church St.	321'-322' from US Manhole	Broken Pipe	1	0	Gravel Alley	City of Mascoutah
MH194	MH031M	114	500 E. Green St.	41'-62' from US Manhole	Severe Sagging	21	0	Asphalt Pavement	City of Mascoutah
MH145	MH144	314	98 N. Lebanon St.	303'-314' from US Manhole	Large Offset Joint	11	0	Asphalt Pavement	City of Mascoutah
MH143	MH144	183	71 N. Lebanon St.	159'-172' from US Manhole	Angular Separation	13	0	Asphalt Parking Lot	-
	MH132		99 W. State St	NA	MH132 sinking, replace manhole	NA	NA	Asphalt Pavement	City of Mascoutah

NOTE:
 1. All utility locations are approximate and Contractor is responsible for utility locates.
 2. Contractor shall protect all underground and overhead utilities. Any damage caused will be responsibility of Contractor
 3. Surface disturbed by construction activities as shown on this exhibit shall be restored to its pre-construction state.
 4. Field verify all pipe sizes and material.

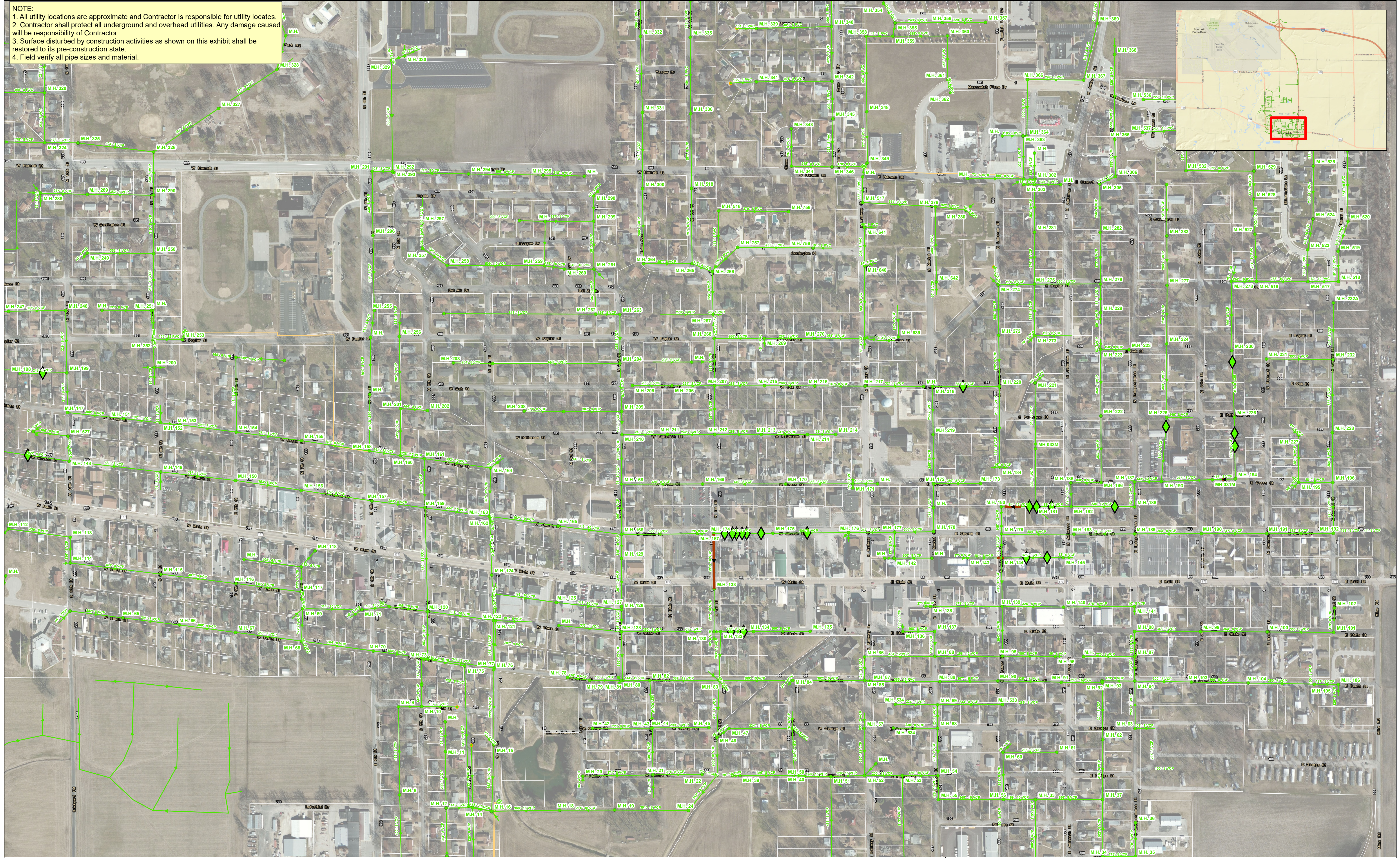
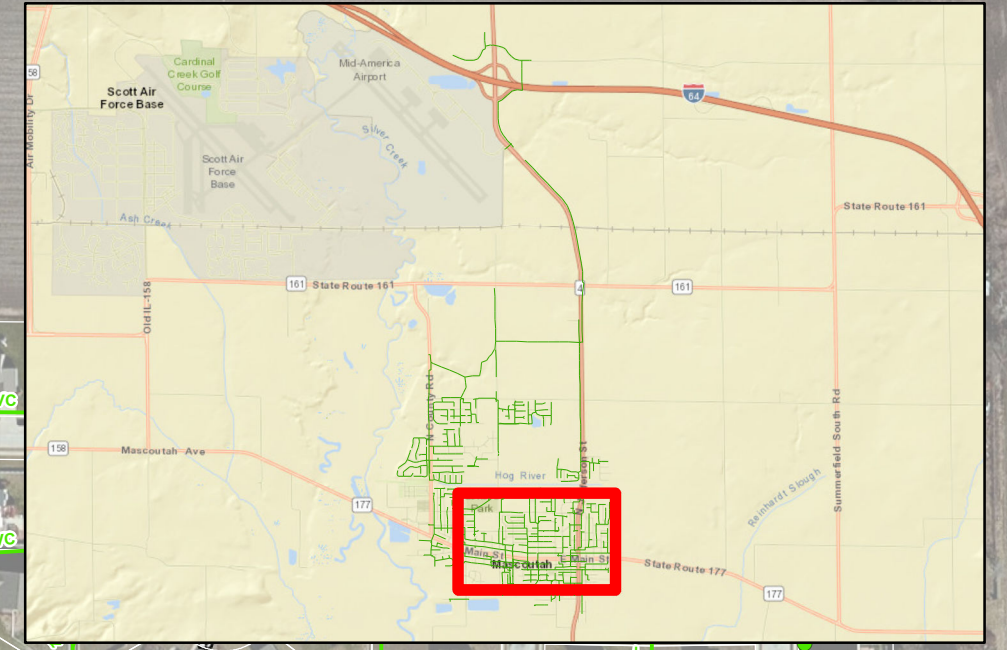

City of Mascoutah, IL
 Overall Open-Cut
 Rehabilitation Map
 Sanitary Sewer Rehabilitation Phase I
 August 2020

- Utilities Legend**
- Sewer Manholes
 - ssGravityMain
 - ◆ Open Cut Lateral Repair Location
 - Open Cut Segment Repair Location

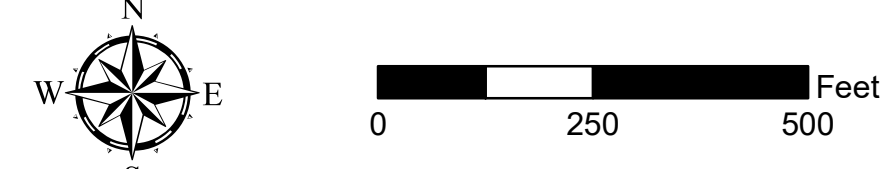

NOTE:
 1. All utility locations are approximate and Contractor is responsible for utility locates.
 2. Contractor shall protect all underground and overhead utilities. Any damage caused will be responsibility of Contractor
 3. Surface disturbed by construction activities as shown on this exhibit shall be restored to its pre-construction state.
 4. Field verify all pipe sizes and material.

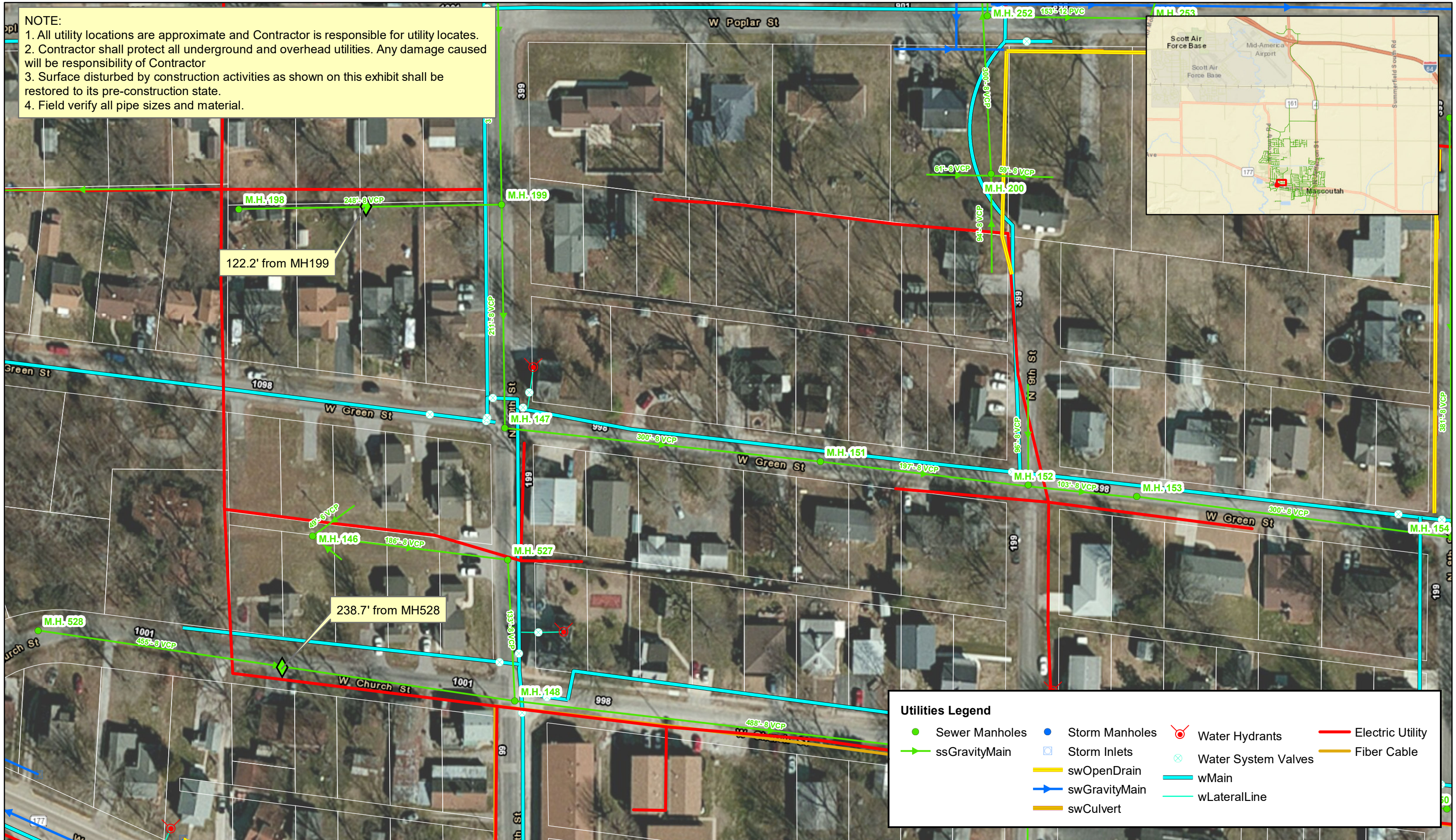
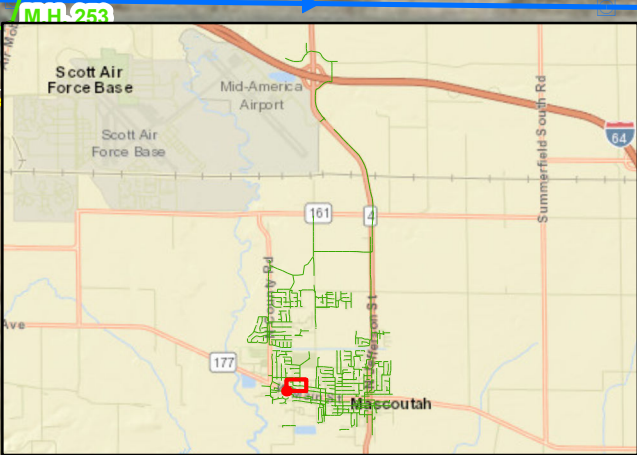

Utilities Legend

● Sewer Manholes	● Storm Manholes	⊗ Water Hydrants	— Electric Utility
→ ssGravityMain	□ Storm Inlets	⊗ Water System Valves	— Fiber Cable
	— swOpenDrain	— wMain	
	— swGravityMain	— wLateralLine	
	— swCulvert		

City of Mascoutah, IL
 Open-cut Repair
 Exhibit 1.1
 Sanitary Sewer Rehabilitation Phase I
 August 2020

◆ Open Cut Lateral Repair Location
 → Open Cut Segment Repair Location

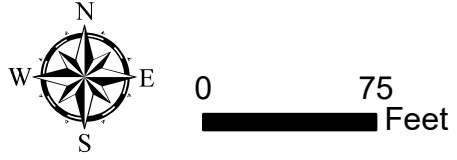

NOTE:

1. All utility locations are approximate and Contractor is responsible for utility locates.
2. Contractor shall protect all underground and overhead utilities. Any damage caused will be responsibility of Contractor
3. Surface disturbed by construction activities as shown on this exhibit shall be restored to its pre-construction state.
4. Field verify all pipe sizes and material.

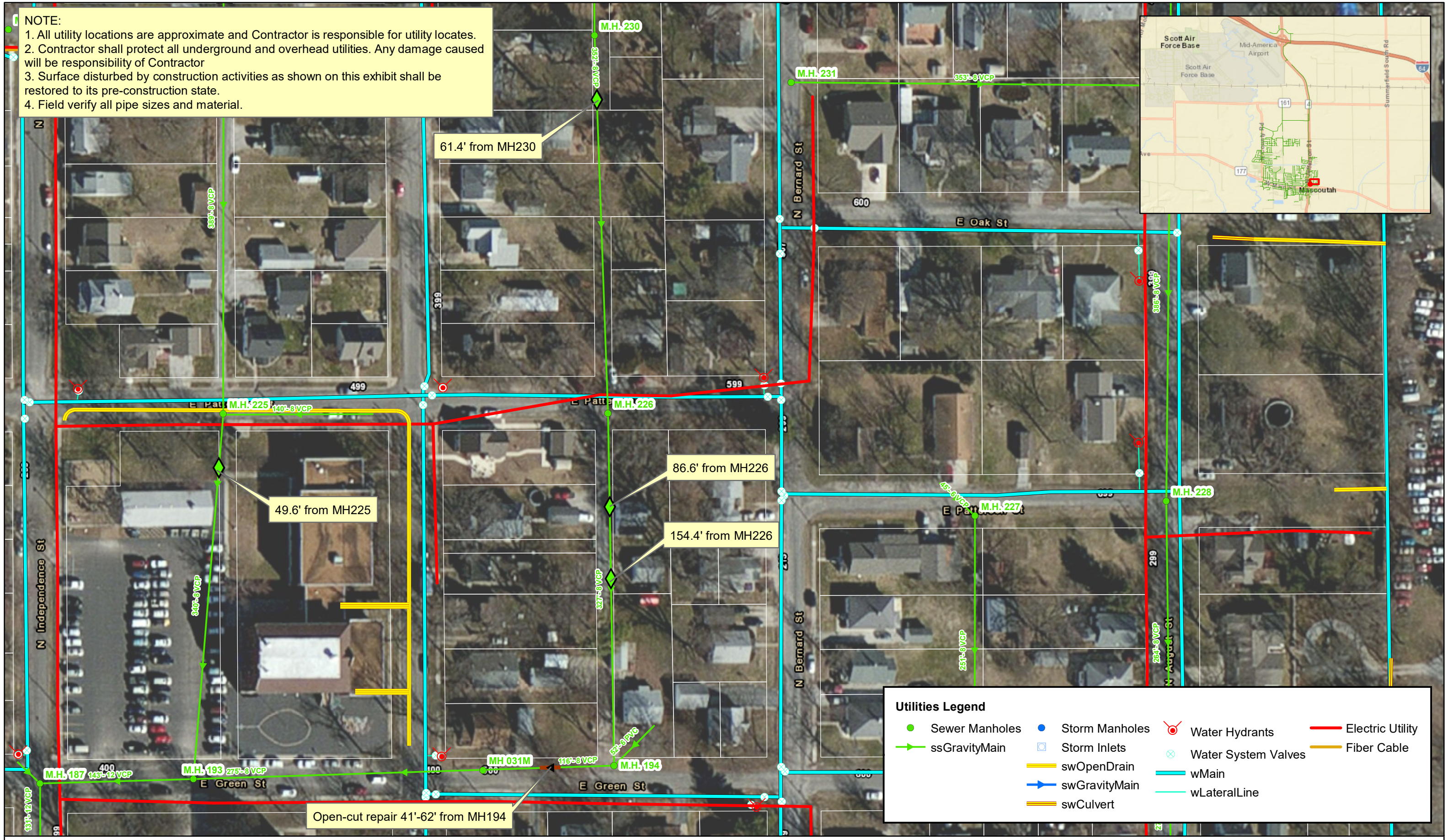
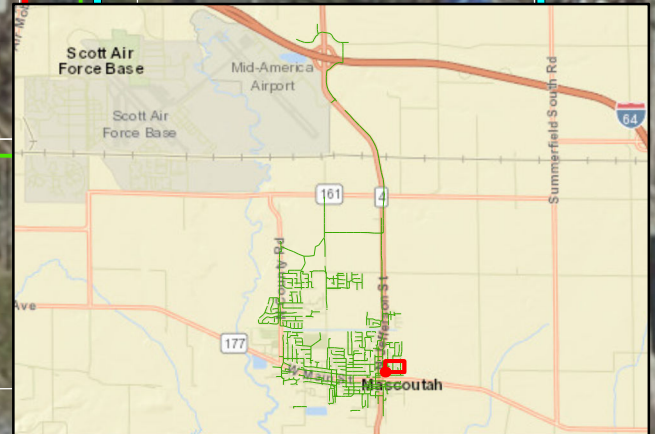

Utilities Legend			
● Sewer Manholes	● Storm Manholes	⊗ Water Hydrants	— Electric Utility
→ ssGravityMain	□ Storm Inlets	⊗ Water System Valves	— Fiber Cable
— swOpenDrain	— swGravityMain	— wMain	
— swCulvert		— wLateralLine	

City of Mascoutah, IL
 Open-cut Repair
 Exhibit 1.2
 Sanitary Sewer Rehabilitation Phase I
 August 2020

◆ Open Cut Lateral Repair Location
 → Open Cut Segment Repair Location

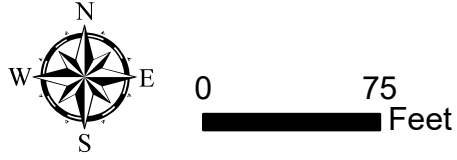

NOTE:
 1. All utility locations are approximate and Contractor is responsible for utility locates.
 2. Contractor shall protect all underground and overhead utilities. Any damage caused will be responsibility of Contractor
 3. Surface disturbed by construction activities as shown on this exhibit shall be restored to its pre-construction state.
 4. Field verify all pipe sizes and material.

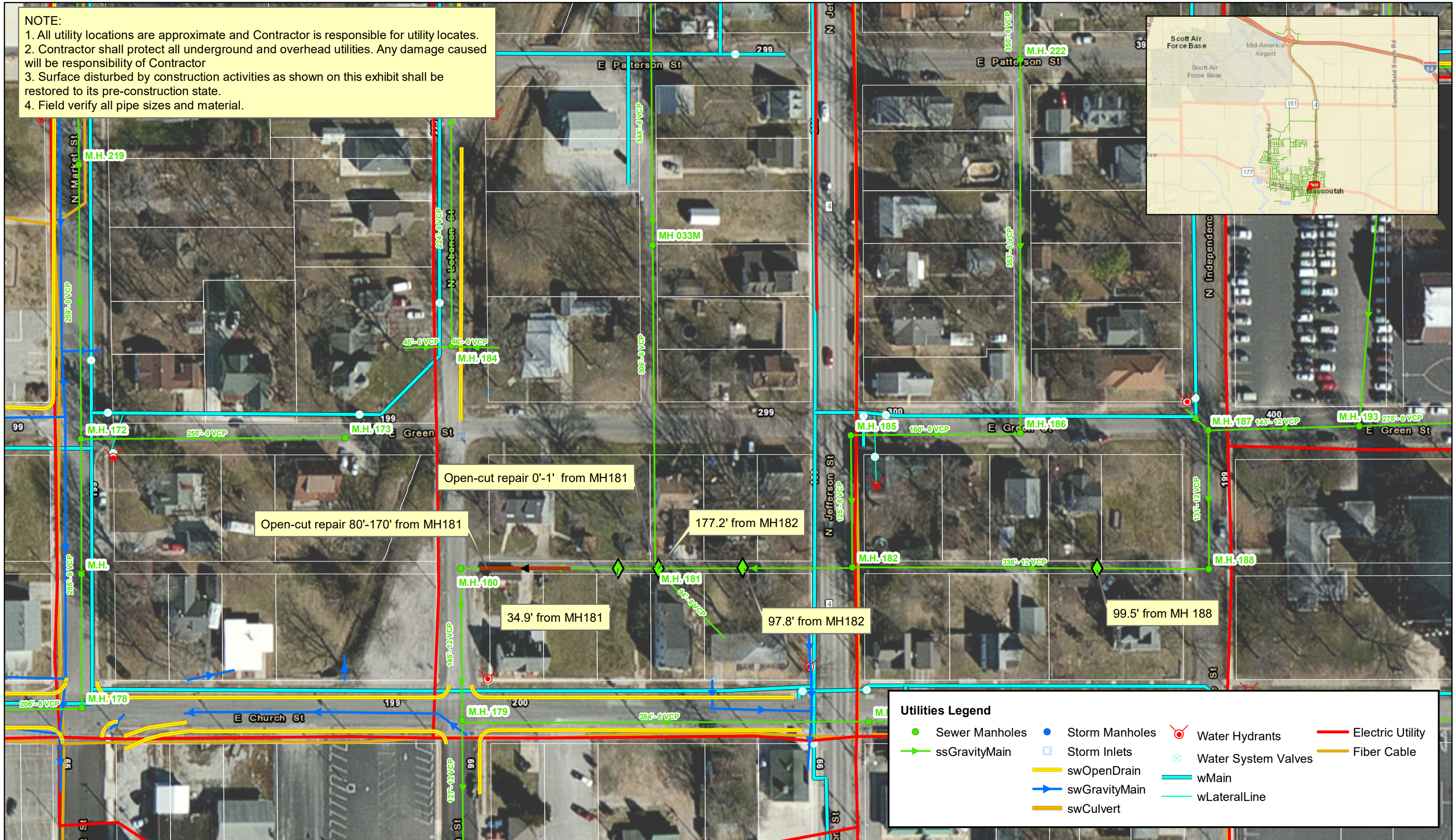
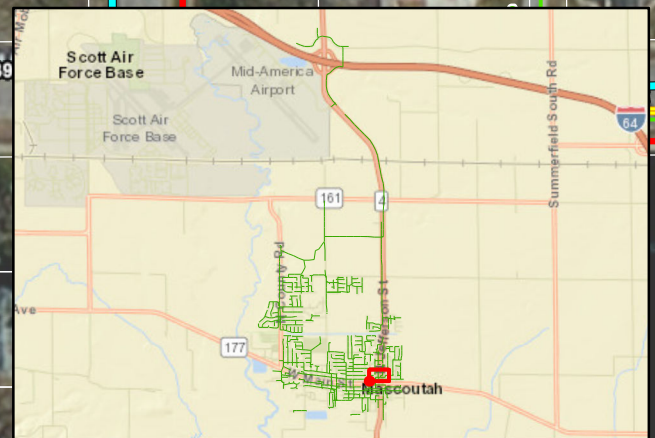

Open-cut repair 0'-1' from MH181

Open-cut repair 80'-170' from MH181

177.2' from MH182

34.9' from MH181

97.8' from MH182

99.5' from MH 188

Utilities Legend

● Sewer Manholes	● Storm Manholes	⊗ Water Hydrants	— Electric Utility
→ ssGravityMain	□ Storm Inlets	⊗ Water System Valves	— Fiber Cable
— swOpenDrain	— swGravityMain	— wMain	
— swCulvert		— wLateralLine	

City of Mascoutah, IL
 Open-cut Repair
 Exhibit 1.3
 Sanitary Sewer Rehabilitation Phase I
 August 2020

◆ Open Cut Lateral Repair Location
 → Open Cut Segment Repair Location

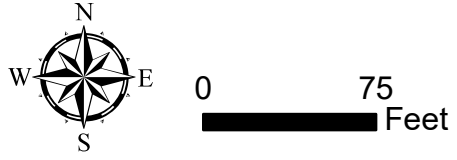

NOTE:
 1. All utility locations are approximate and Contractor is responsible for utility locates.
 2. Contractor shall protect all underground and overhead utilities. Any damage caused will be responsibility of Contractor
 3. Surface disturbed by construction activities as shown on this exhibit shall be restored to its pre-construction state.
 4. Field verify all pipe sizes and material.

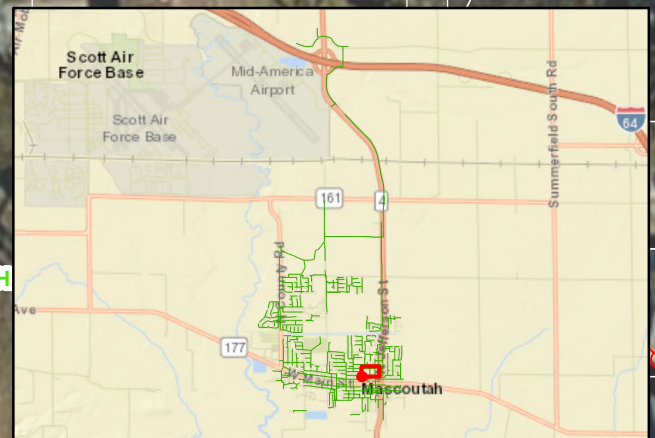
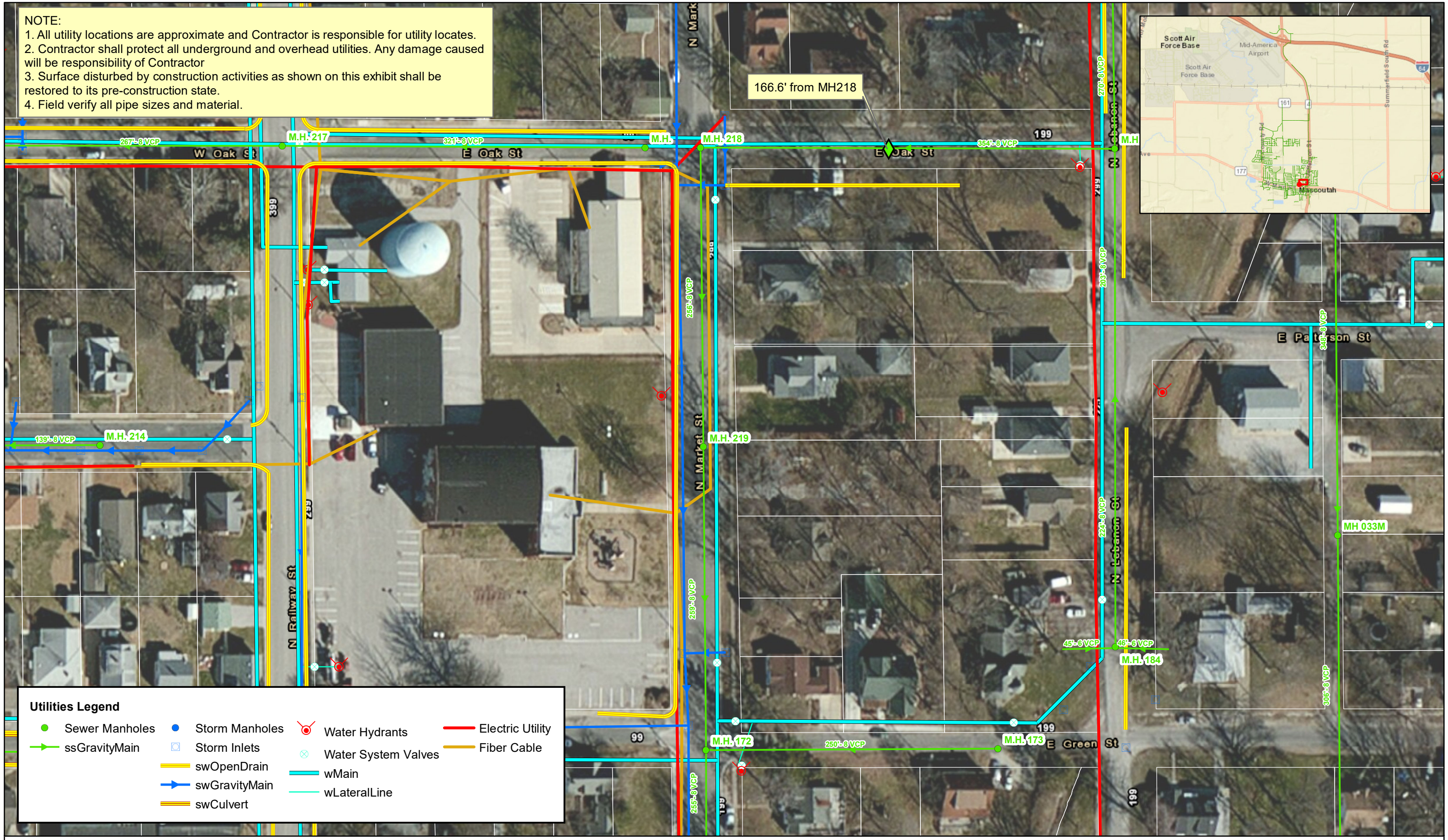

Utilities Legend

● Sewer Manholes	● Storm Manholes	⊗ Water Hydrants	— Electric Utility
→ ssGravityMain	□ Storm Inlets	⊗ Water System Valves	— Fiber Cable
— swOpenDrain	— wMain		
→ swGravityMain	— wLateralLine		
— swCulvert			

◆ Open Cut Lateral Repair Location
 → Open Cut Segment Repair Location



City of Mascoutah, IL
 Open-cut Repair
 Exhibit 1.4
 Sanitary Sewer Rehabilitation Phase I
 August 2020



NOTE:
 1. All utility locations are approximate and Contractor is responsible for utility locates.
 2. Contractor shall protect all underground and overhead utilities. Any damage caused will be responsibility of Contractor
 3. Surface disturbed by construction activities as shown on this exhibit shall be restored to its pre-construction state.
 4. Field verify all pipe sizes and material.

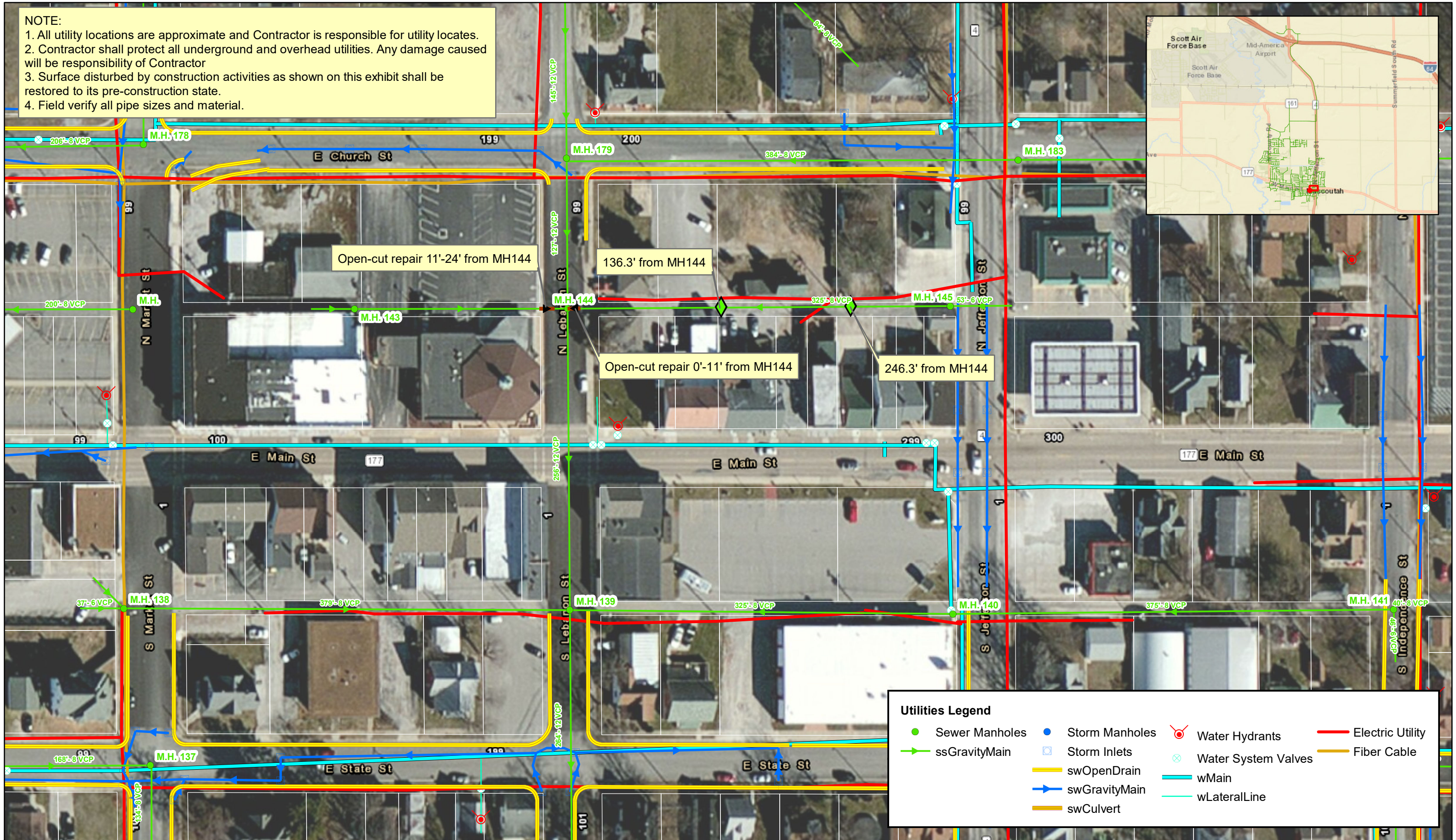
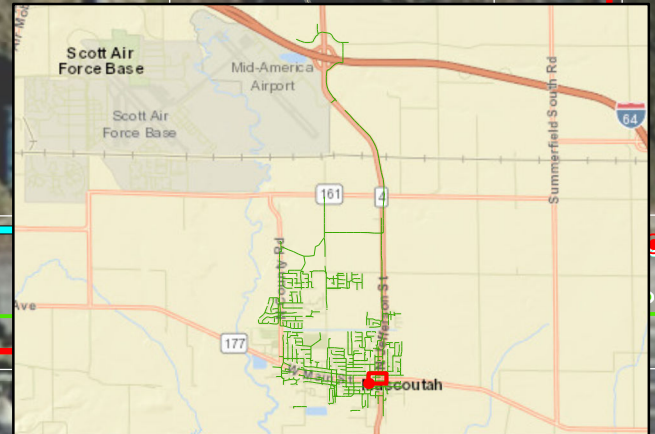

Utilities Legend

● Sewer Manholes	● Storm Manholes	⊗ Water Hydrants	— Electric Utility
→ ssGravityMain	□ Storm Inlets	⊗ Water System Valves	— Fiber Cable
	— swOpenDrain	— wMain	
	— swGravityMain	— wLateralLine	
	— swCulvert		

City of Mascoutah, IL
 Open-cut Repair
 Exhibit 1.5
 Sanitary Sewer Rehabilitation Phase I
 August 2020

◆ Open Cut Lateral Repair Location
 → Open Cut Segment Repair Location



NOTE:
 1. All utility locations are approximate and Contractor is responsible for utility locates.
 2. Contractor shall protect all underground and overhead utilities. Any damage caused will be responsibility of Contractor
 3. Surface disturbed by construction activities as shown on this exhibit shall be restored to its pre-construction state.
 4. Field verify all pipe sizes and material.

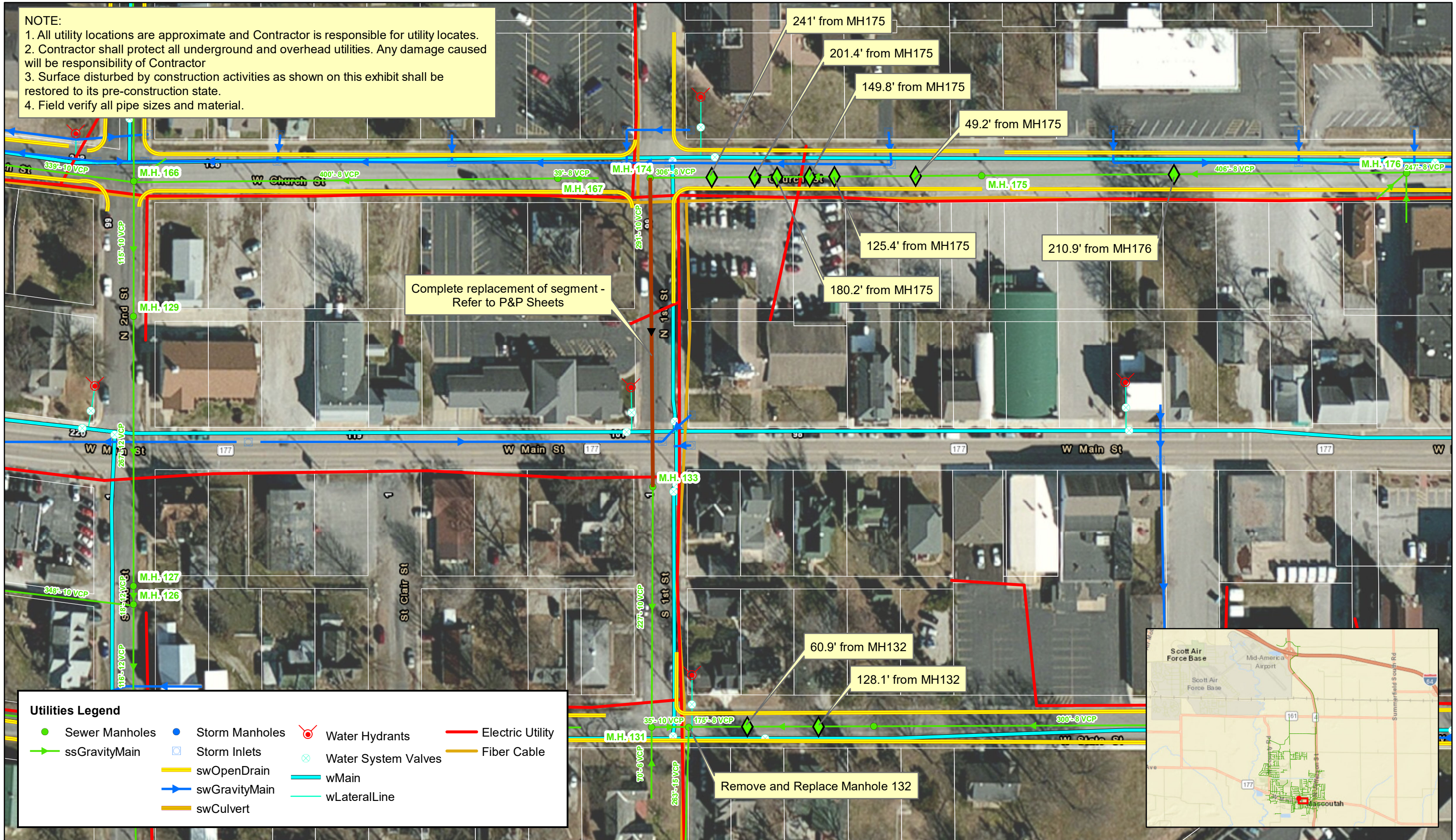

Utilities Legend

● Sewer Manholes	● Storm Manholes	⊗ Water Hydrants	— Electric Utility
→ ssGravityMain	□ Storm Inlets	⊗ Water System Valves	— Fiber Cable
— swOpenDrain	— wMain		
→ swGravityMain	— wLateralLine		
— swCulvert			

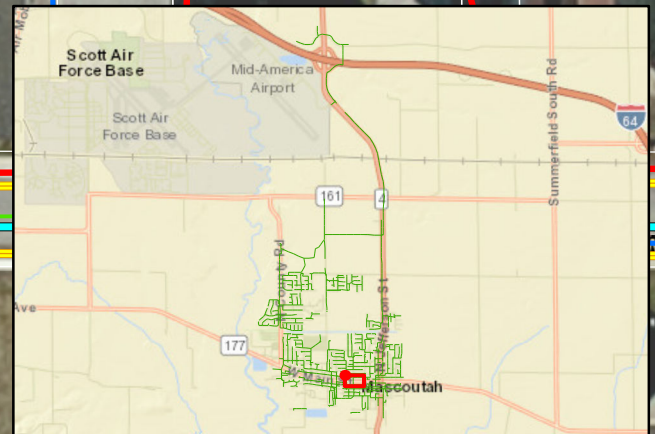

City of Mascoutah, IL
 Open-cut Repair
 Exhibit 1.6
 Sanitary Sewer Rehabilitation Phase I
 August 2020

◆ Open Cut Lateral Repair Location
 → Open Cut Segment Repair Location



**CITY OF MASCOUTAH
2020 SANITARY SEWER REHABILITATION PHASE I
PIPE LINING SCHEDULE**

ASSET ID	USMH	DSMH	Location	Pipe Diameter (in)	Material	TV Length (ft)	No Live Services	No Protruding Taps	No Capped Service
MH226-MH194	MH226	MH194	Between N. Bernard St. & N. John St.	8	VCP	325	13	0	0
MH230-MH226	MH230	MH226	Between N. Bernard St. & N. John St.	8	VCP	352	18	0	0
MH173-MH172	MH173	MH172	E. Green St.	8	VCP	247	5	3	3
MH220-MH218	MH220	MH218	E. Oak St.	8	PVC	355	4	0	5
MH151-MH152	MH151	MH152	W. Green St.	8	VCP	198	5	0	4
MH232-MH228	MH232	MH228	N. August St.	8	VCP	389	4	3	6
MH147-MH151	MH147	MH151	W. Green St.	8	VCP	300	6	1	4
MH182-MH181	MH182	MH181	Between N. Jefferson St. & N. Lebanon St.	10	VCP	188	7	0	0
8" TOTAL						2,166	55	7	22
10" TOTAL						188	7	0	0
TOTAL						2,354	62	7	22

*Contractor to reinstate one lateral per property

NOTE:
1. Contractor to verify locations and sizes of sewers prior to starting any type of field work.



City of Mascoutah, IL
Overall Map
Lining and Grouting of Reinstated Laterals
Sanitary Sewer Rehabilitation Phase I
August 2020

- Utilities Legend**
- Sewer Manholes
 - ssGravityMain

- Recommendation Lining Priority**
- High Lining Priority

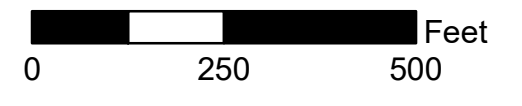

NOTE:
 1. Contractor to verify locations and sizes of sewers prior to starting any type of field work.

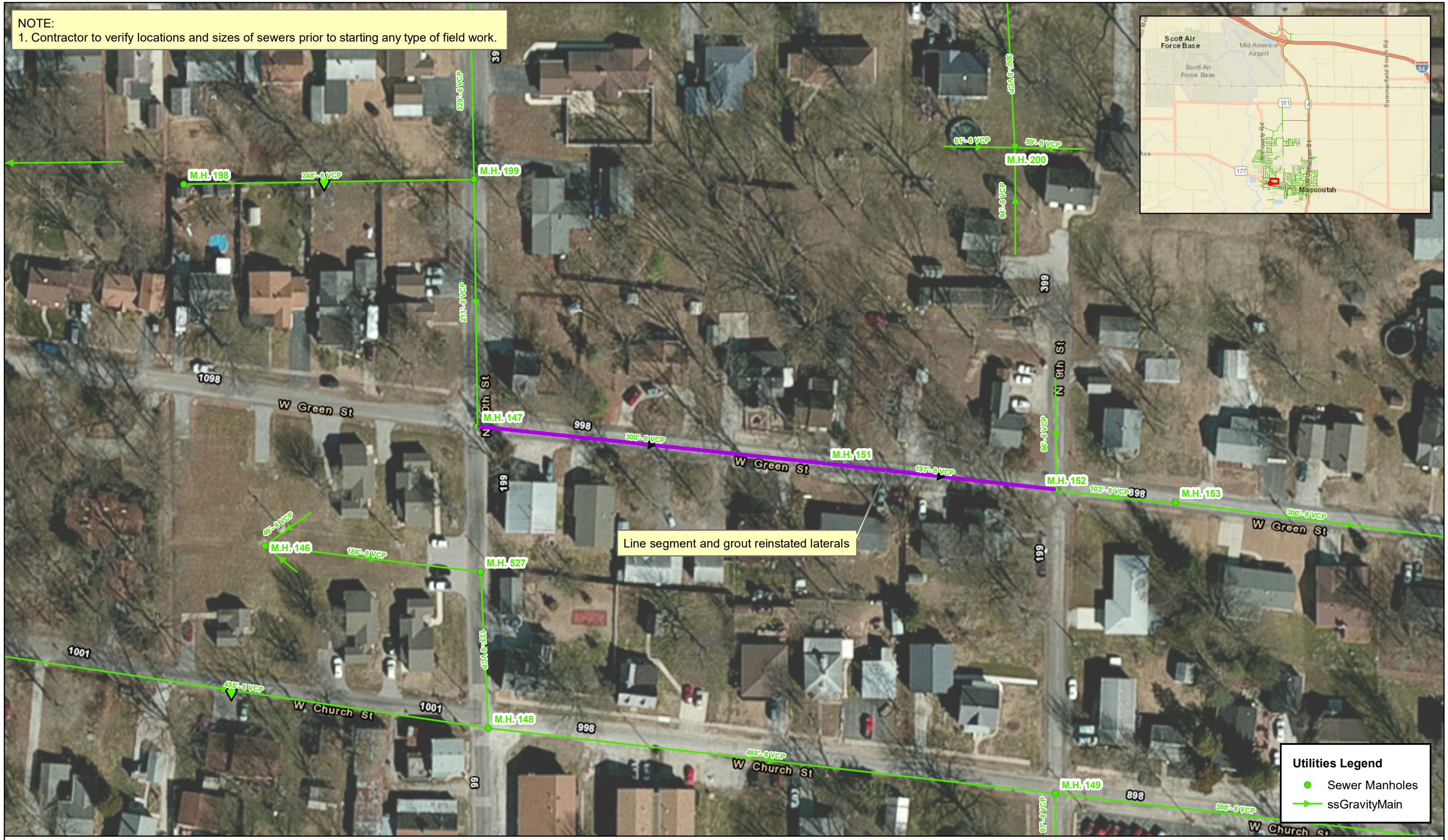
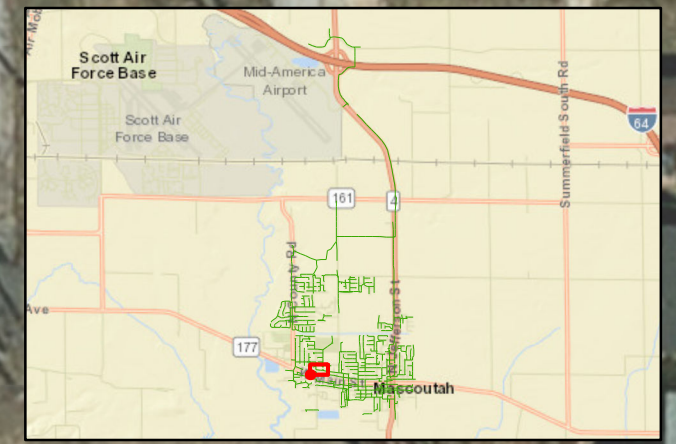

Line segment and grout reinstated laterals

Utilities Legend

- Sewer Manholes
- ssGravityMain

City of Mascoutah, IL
 Lining and Grouting of Reinstated Laterals
 Exhibit 2.1
 Sanitary Sewer Rehabilitation Phase I
 August 2020

Recommendation Lining Priority
▶ High Lining Priority

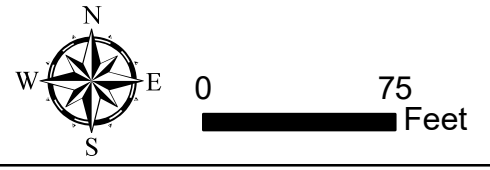

NOTE:
 1. Contractor to verify locations and sizes of sewers prior to starting any type of field work.

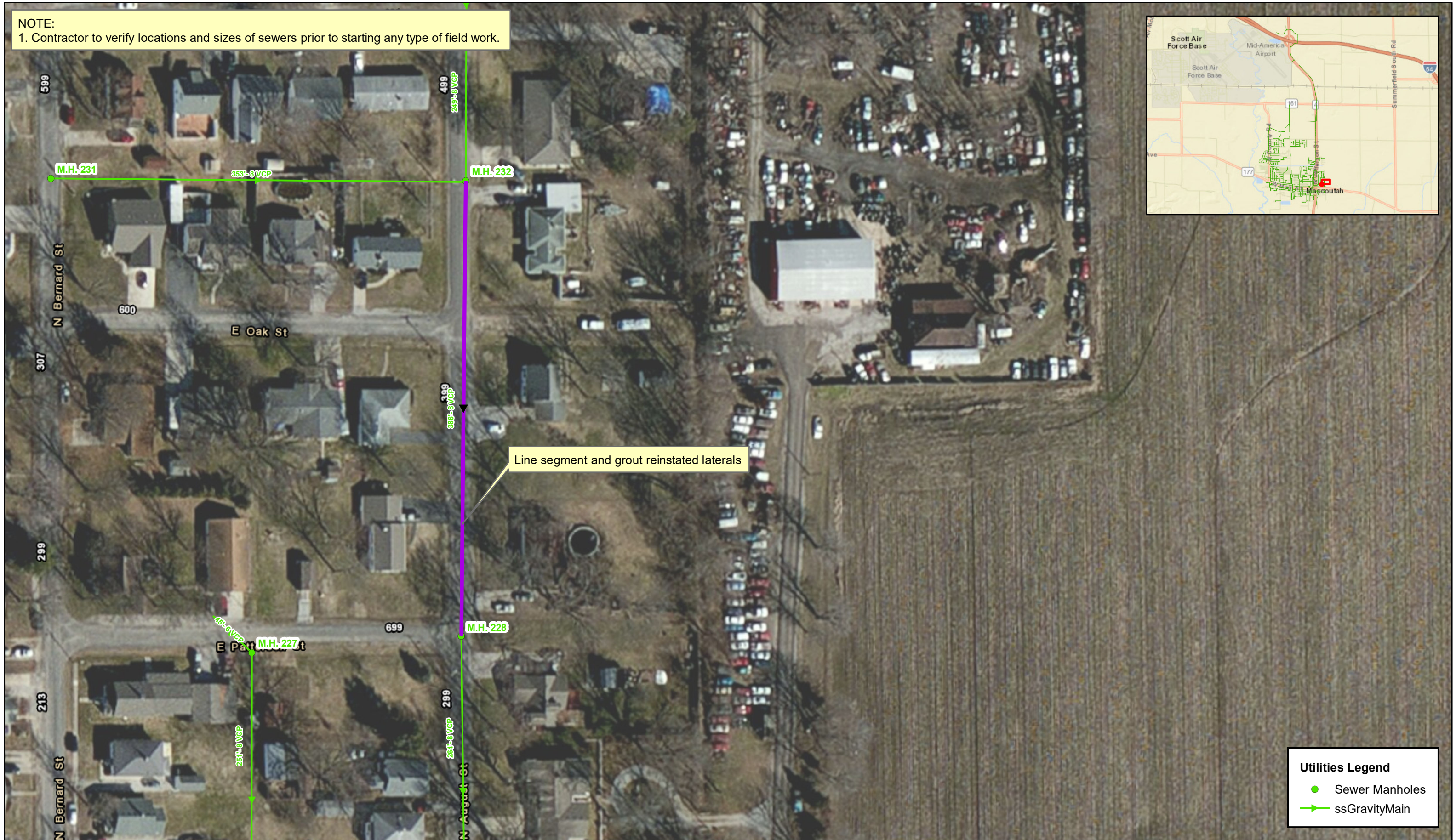
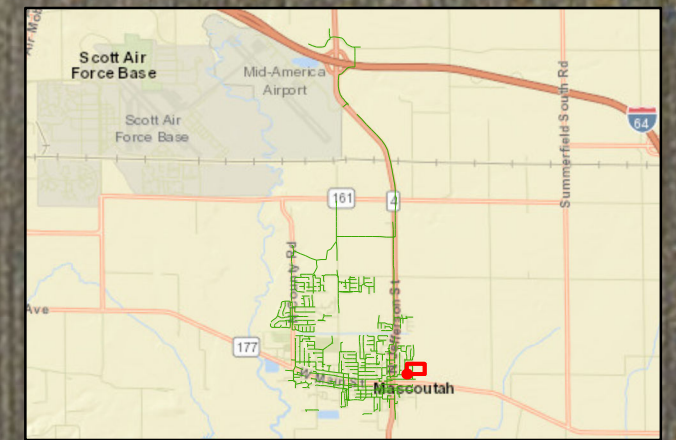

Utilities Legend

- Sewer Manholes
- ▶ ssGravityMain

City of Mascoutah, IL
 Lining and Grouting of Reinstated Laterals
 Exhibit 2.2
 Sanitary Sewer Rehabilitation Phase I
 August 2020

Recommendation Lining Priority
▶ High Lining Priority



NOTE:
1. Contractor to verify locations and sizes of sewers prior to starting any type of field work.

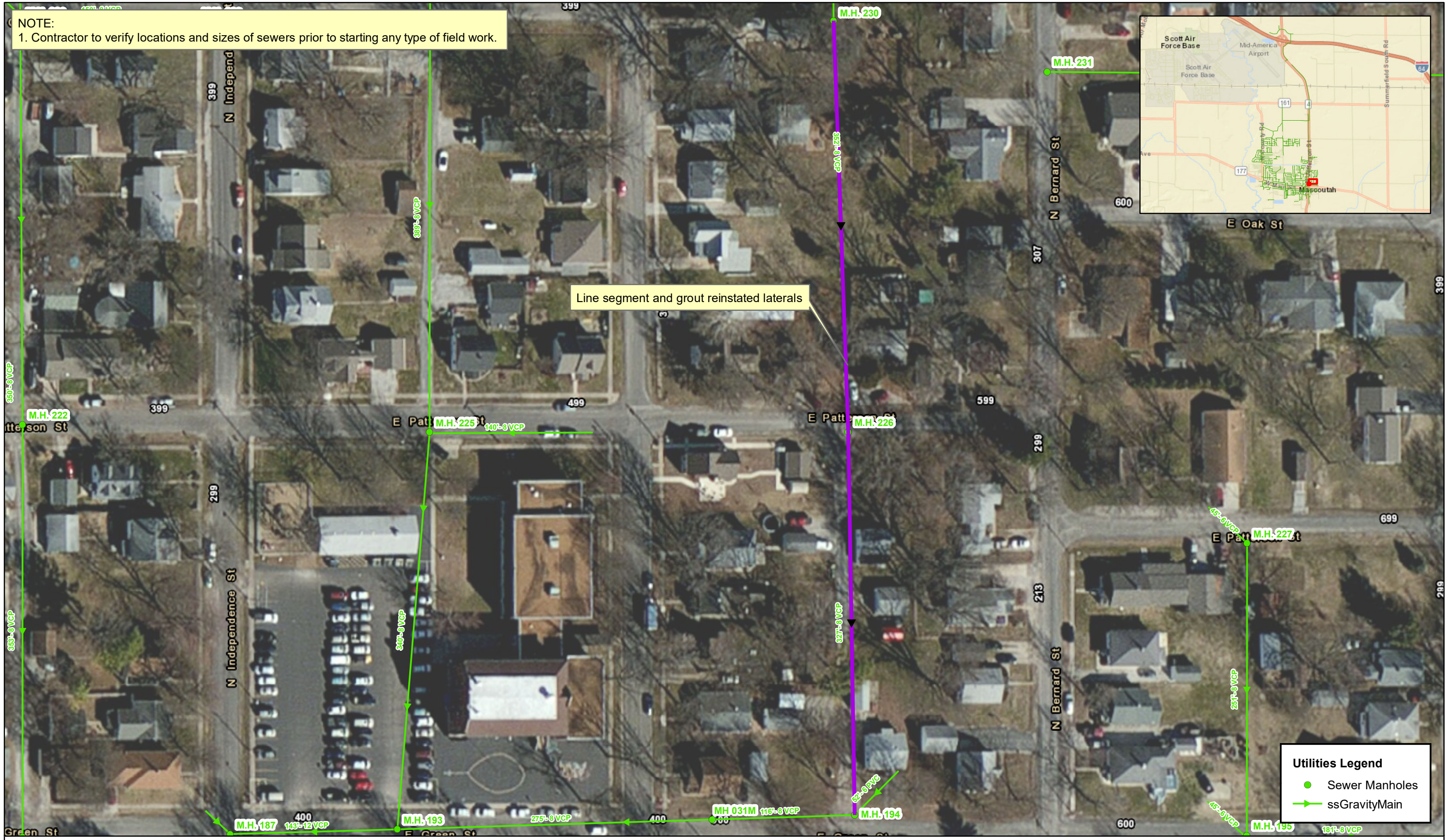

Line segment and grout reinstated laterals

Utilities Legend

- Sewer Manholes
- ssGravityMain

City of Mascoutah, IL
Lining and Grouting of Reinstated Laterals
Exhibit 2.3
Sanitary Sewer Rehabilitation Phase I
August 2020

Recommendation Lining Priority
 High Lining Priority

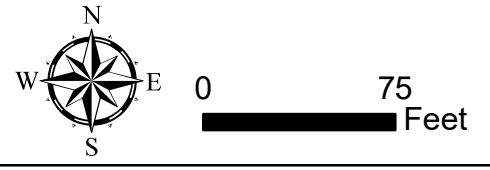

NOTE:
 1. Contractor to verify locations and sizes of sewers prior to starting any type of field work.

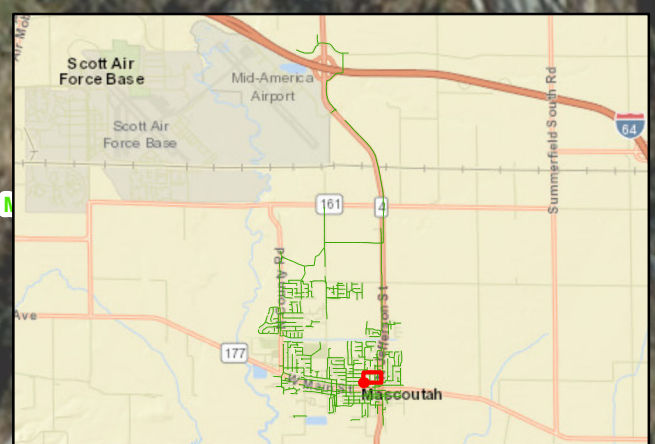
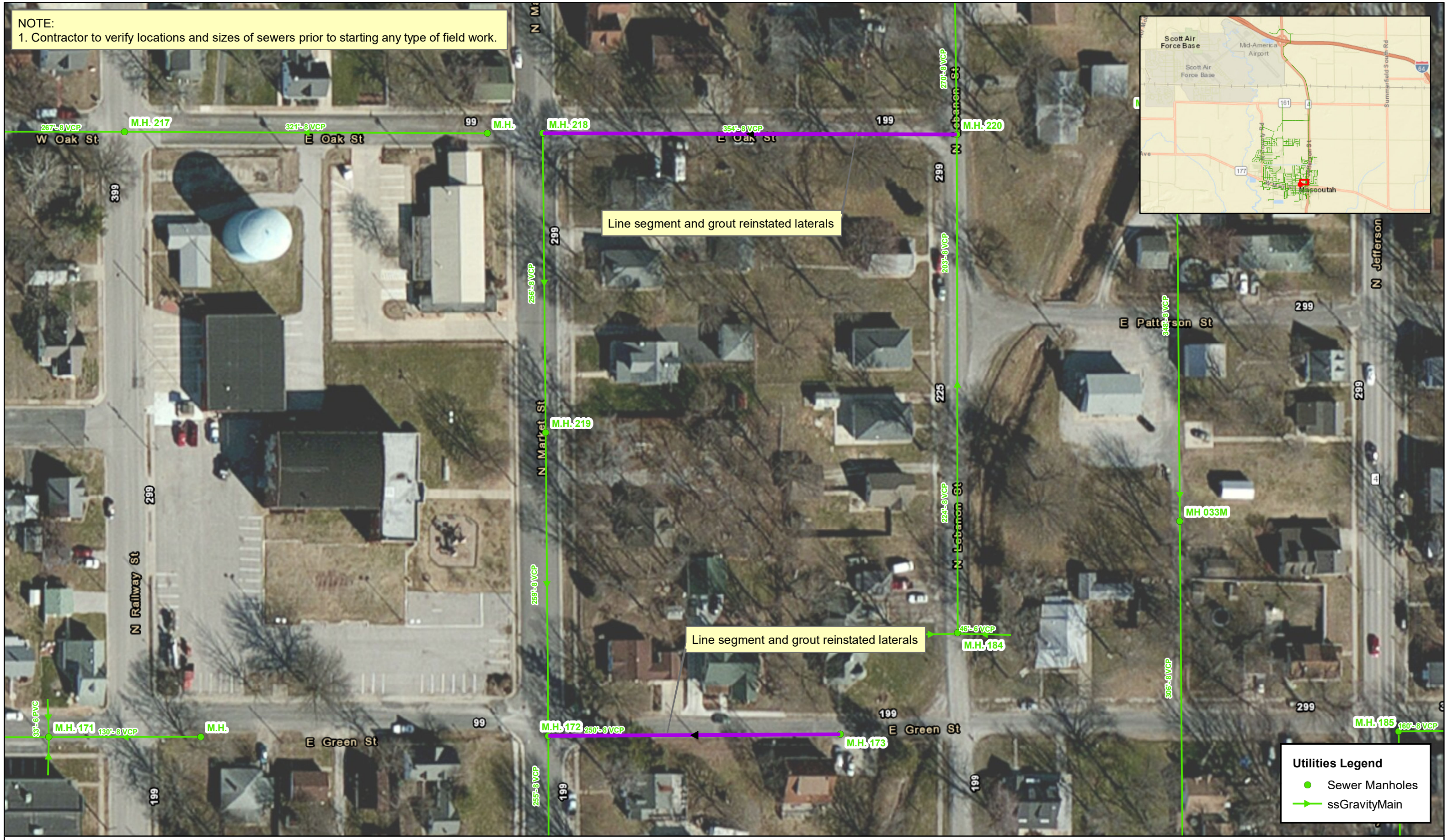

Line segment and grout reinstated laterals

Line segment and grout reinstated laterals

Utilities Legend

- Sewer Manholes
- ssGravityMain

City of Mascoutah, IL
 Lining and Grouting of Reinstated Laterals
 Exhibit 2.4
 Sanitary Sewer Rehabilitation Phase I
 August 2020

Recommendation Lining Priority
 ► High Lining Priority



NOTE:
 1. Contractor to verify locations and sizes of sewers prior to starting any type of field work.

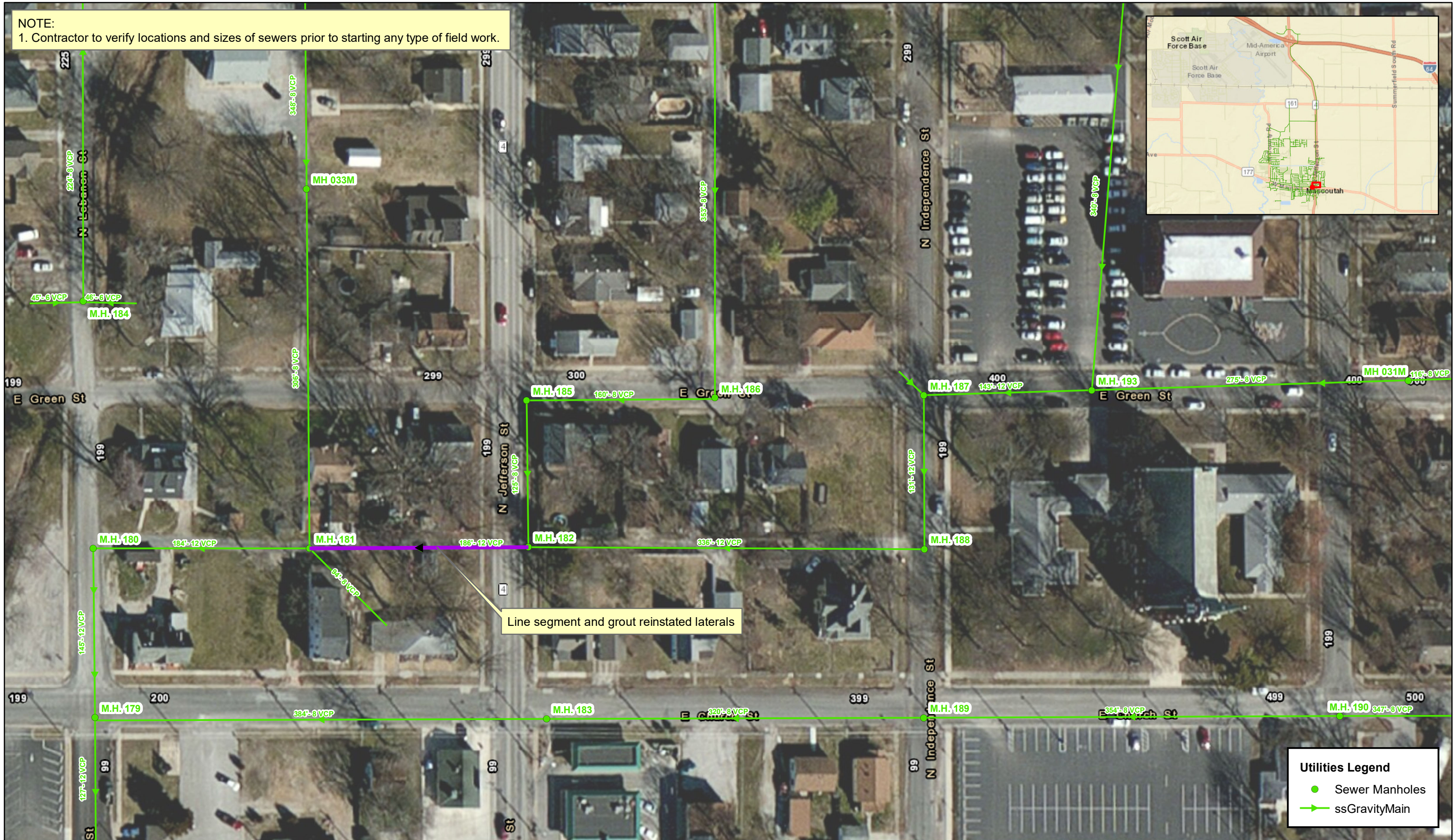
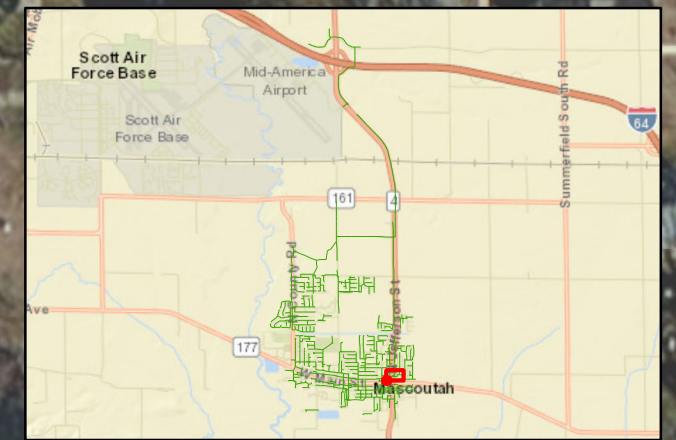

Utilities Legend

- Sewer Manholes
- ssGravityMain

City of Mascoutah, IL
 Lining and Grouting of Reinstated Laterals
 Exhibit 2.5
 Sanitary Sewer Rehabilitation Phase I
 August 2020

Recommendation Lining Priority
 ▶ High Lining Priority



**CITY OF MASCOUTAH
2020 SANITARY SEWER REHABILITATION PHASE I
CIPP POINT REPAIR SCHEDULE FOR SEGMENTS**

USMH	DSMH	Segment Length (ft)	Approximate Address	Repair Location	Repair Type	Repair Length ft)	Number of Live Services Within CIPP Repair
MH176	MH175	405	33 W. Church St.	96'-100' from US Manhole	Hole in Pipe, CIPP Point Repair	4	0
MH176	MH175	405	34 W. Church St.	180'-183' from US Manhole	Hole in Pipe, CIPP Point Repair	3	1
MH180	MH179	145	200 E. Church St.	115'-125' from US Manhole	Utility Cable Bored Through Pipe, CIPP Point Repair	10	0
MH276	MH275	351	299 E. Poplar St.	165'-185' from US Manhole	Hole in Pipe, CIPP Point Repair	20	0
						37	1

NOTE:
1. Contractor to verify locations and sizes of sewers prior to starting any type of field work.

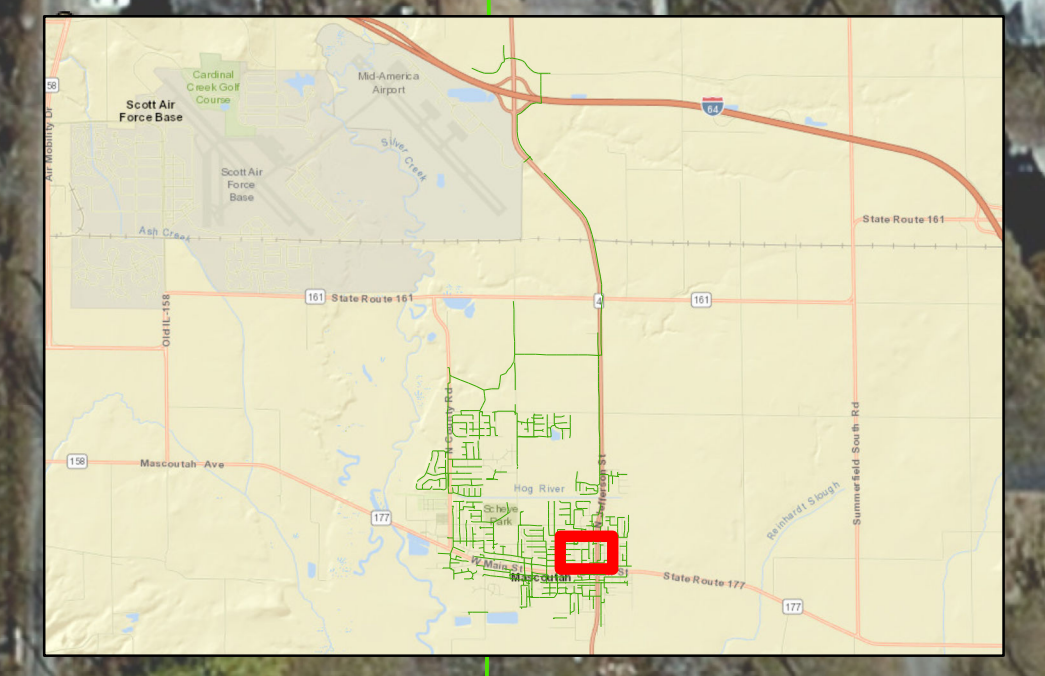

City of Mascoutah, IL
Overall Map
CIPP Point Repair of Segments
Sanitary Sewer Rehabilitation Phase I
August 2020

- Utilities Legend**
- Sewer Manholes
 - ssGravityMain
 - Point Repair



NOTE:
 1. Contractor to verify locations and sizes of sewers prior to starting any type of field work.

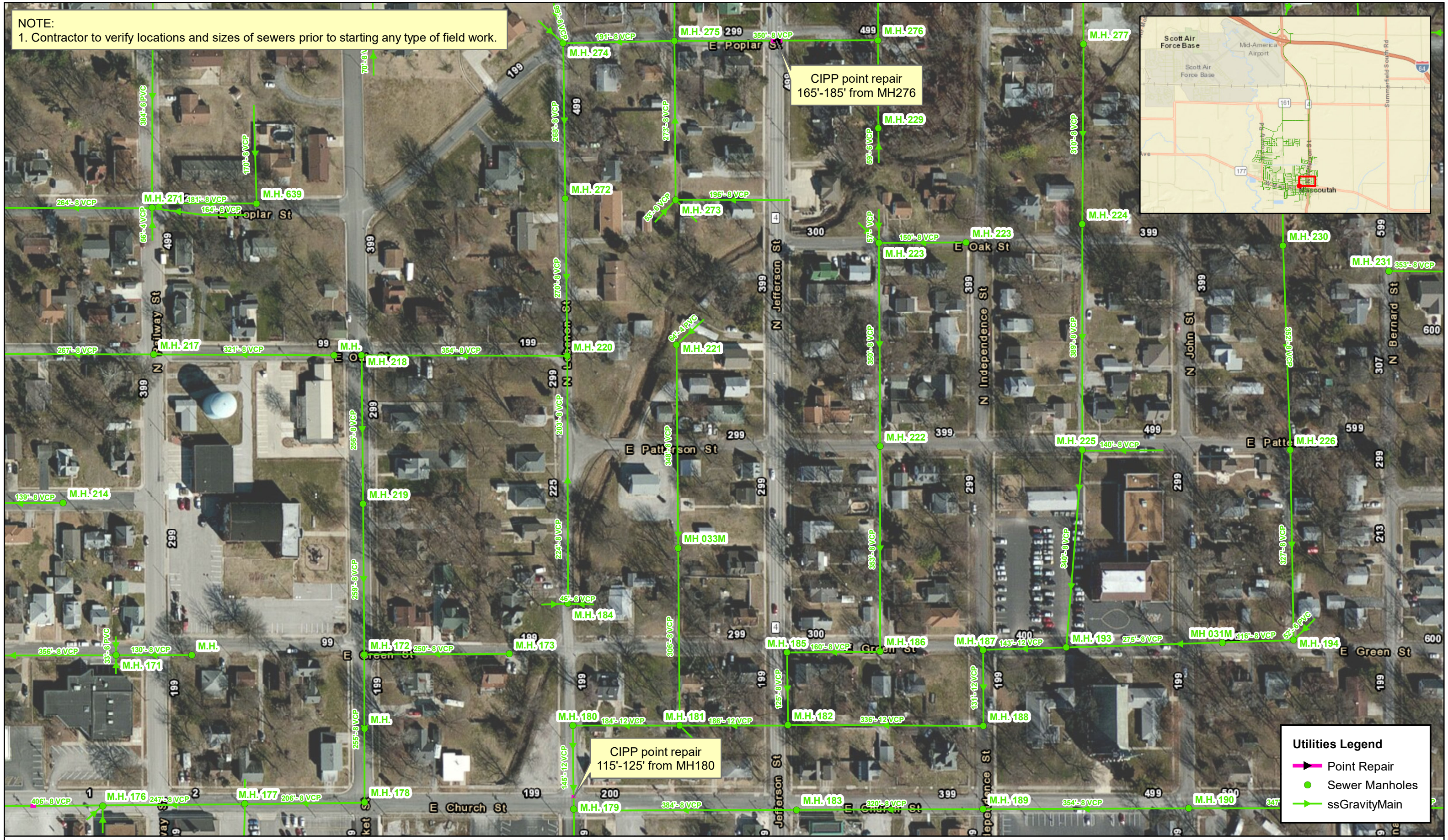
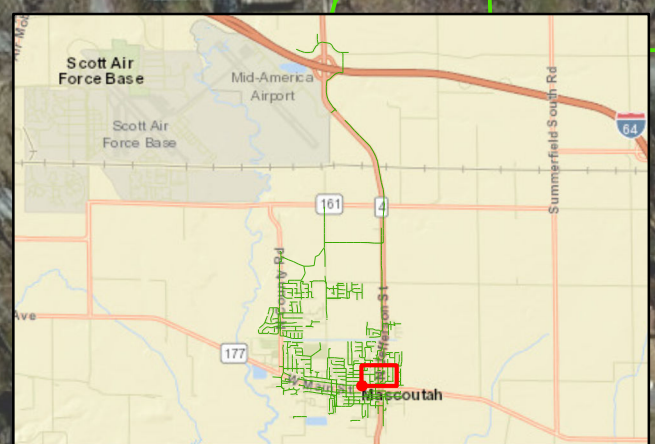

Utilities Legend

- Point Repair
- Sewer Manholes
- ssGravityMain

City of Mascoutah, IL
 CIPP Point Repair of Segments
 Exhibit 3.1
 Sanitary Sewer Rehabilitation Phase I
 August 2020

Point Repair



0 75 Feet



NOTE:
1. Contractor to verify locations and sizes of sewers prior to starting any type of field work.



Utilities Legend

- Sewer Manholes
- ssGravityMain

▶ Point Repair

City of Mascoutah, IL
CIPP Point Repair of Segments
Exhibit 3.2
Sanitary Sewer Rehabilitation Phase I
August 2020



**GEOTECHNICAL INTERPRETIVE
REPORT FOR OPEN-CUT
REPLACEMENT OF SEGMENT
MH174:MH133**

REPORT
2020088307

**GEOTECHNICAL INTERPRETIVE REPORT FOR
SANITARY SEWER LINE REPLACEMENT IN
MASCOUTAH, ILLINOIS**

Prepared for



RJN GROUP

Prepared by



May 13, 2020

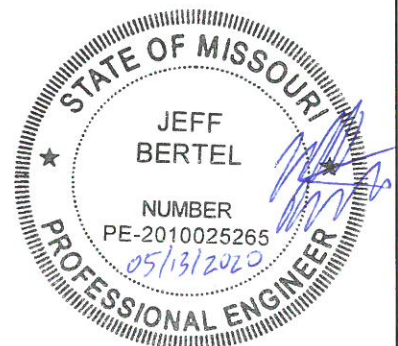

The Professional whose signature and personal seal appear hereon assumes responsibility only for what appears in the attached report and disclaims any responsibility for all other plans, estimates, specifications, reports, or other documents or instruments not sealed by the undersigned Professional relating to or intended to be used for any part or parts of the project to which this report refers.

Executive Summary

This report presents the results of our geotechnical investigation for the proposed replacement sanitary sewer line in Mascoutah, Illinois. The sewer line stretches from Manhole 133, located near the intersection of W Main Street and S 1st Street, north about 300 feet to Manhole 174. Manhole 174 is at the intersection of W Church Street and N 1st Street.

Three borings, labeled B-1 thru B-3, were made for this investigation. The borings generally revealed firm to stiff, silty clay. Groundwater was not encountered in the borings.

The new sewer will be installed by using an open excavation between W Church Street and W Main Street. The southern-most extent of the sewer, beneath W Main Street/ IL Highway 177, will be installed via trenchless installation.

Excavations may need to be shored, probably using internal bracing (wales and struts). Recommended minimum lateral earth pressure diagrams are included in this report for the design of braced excavation shoring.

Table of Contents

	<u>Page</u>
EXECUTIVE SUMMARY	ES-i
INTRODUCTION	1
PROJECT DESCRIPTION.....	1
SITE DESCRIPTION.....	1
SUBSURFACE INVESTIGATION.....	1
LABORATORY TESTING PROGRAM.....	2
SUMMARY OF SUBSURFACE CONDITIONS ENCOUNTERED.....	2
EVALUATION AND RECOMMENDATIONS	3
Design of Manholes	3
Open Excavations and Shoring.....	3
Subgrade and Bedding	4
Control of Ground Water	4
Tunneling	4
Backfilling	5
Summary of Recommendations.....	5
LIMITATIONS	6

LIST OF FIGURES

	<u>Figure(s)</u>
Approximate Locations of Borings B-1, B-2 and B-3	1
Key to Boring Logs	2-0
Log for Boring B-1	2-1
Log for Boring B-2	2-2
Log for Boring B-3	2-3
Triaxial Laboratory Data	3-1 thru 3-3
Lateral Earth Pressure Diagrams for Design of Braced Excavations	4

Geotechnical Interpretive Report for Sanitary Sewer Line Replacement in Mascoutah, Illinois

INTRODUCTION

This report presents the results of our geotechnical investigation for the proposed replacement of an existing sewer line in Mascoutah, Illinois. The upstream end of the study reach begins at Manhole 174, located near the southwest corner of W Church Street and N 1st Street. The downstream end of the study reach is at existing Manhole 133, located on southwest corner of W Main Street and S 1st Street. Main Street is also IDOT Highway 177. The study reach is shown in Figure 1. This investigation was done in general accordance with our Subconsultant Agreement, dated April 3, 2020.

The purpose of this investigation was to characterize the subsurface conditions as they pertain to the proposed replacement of the sanitary sewer.

Because the scope of services and level of effort are specific to the needs of this project, the contents of this report may not address items critical to other projects. Therefore, this report is not to be used for other projects or by third parties without Reitz & Jens' written authorization.

PROJECT DESCRIPTION

The City of Mascoutah plans to replace the existing 10-in. sanitary sewer. The total length of the sanitary sewer replacement project is about 300 feet.

SITE DESCRIPTION

The site is generally level and in a developed urban area. The site conditions are illustrated by the aerial photo reproduced in Figure 1. The existing alignment to be replaced begins at Manhole 174 and proceeds south about 300 feet to Manhole 133. The proposed sewer invert is about 13 feet deep.

The general soils geology consists of modified silty clay loess, which is underlain by glacial till. According to local water well logs, Pennsylvanian-age shale is about 100 feet deep.

SUBSURFACE INVESTIGATION

The field work for this investigation along the alignment consisted of three borings, the approximate locations of which are shown in Figure 1. The borings were located by Reitz & Jens using measured distances from existing features in the field as shown in the preliminary plan furnished by RJN, dated February 5, 2020. Neither a topographic map, nor a benchmark was provided, so elevations were not provided on the boring logs.

The borings were drilled on April 16, 2020. The borings were made by Midwest Drilling, Inc. of Florissant, Missouri, under a subcontract with Reitz & Jens. The borings were advanced using 4.25-inch O.D. solid continuous-flight augers. The borings were drilled to 20 feet deep. Auger refusal did not occur in any of the borings. The field investigation was done under the direction of a Reitz & Jens geotechnical engineer, who determined the sampling intervals and the termination depths, collected soil samples, and logged the borings. Detailed boring logs are included in Figures 2-1 thru 2-3. The legend for the boring logs is in Figure 2-0.

Samples of subsurface materials generally were obtained at about 5-foot intervals, with additional samples taken at about 2.5 feet above and below the approximate proposed sewer invert. Two types of samplers were used: 1) a hydraulically pushed, 3-in. O.D., thin-walled Shelby tube sampler (ASTM D1587); or 2) a 2-in. O.D., split-spoon sampler driven by an automatic hammer in conjunction with a Standard Penetration Test (ASTM D1586). Published tests have shown that the blow counts, or N-values, from a Standard Penetration Test (SPT) using an automatic hammer are less than the blow counts for a manual drop and cathead that have been used to develop correlations between N-values and soil properties. The efficiency of a manual hammer is about 60%. The efficiency of the automatic hammer on the CME-750 drilling rig has historically been measured to be about 60%. Therefore, the blow counts, or N-values, should not be increased to use such correlations. The uncorrected blow counts are shown on the boring logs.

The disturbed split-spoon samples obtained were visually classified in the field and sealed in glass jars to prevent loss of moisture, for later testing in the laboratory. The relatively undisturbed Shelby tube samples were sealed in the tubes and were extruded from the tubes immediately prior to testing in the lab. Borings were logged in the field based upon cuttings, drilling characteristics and recovered samples. Boring logs were subsequently modified as appropriate based on laboratory tests results.

LABORATORY TESTING PROGRAM

All recovered samples were visually described in general accordance with the Unified Soil Classification System and the Standard Test Method for Classification, Description, and Identification of Soils (ASTM D2487 and D2488). Index tests performed included water contents on all cohesive samples, and dry unit weights (ASTM D2216) on selected Shelby tube samples. The results of these index tests appear on the borings logs in Figures 2-1 thru 2-3.

We performed three single point unconsolidated-undrained (UU) triaxial compression tests (ASTM D2850) on Shelby tube samples, to determine the undrained shear strengths (s_u) of the various subsurface soils at their insitu overburden pressures. The results of the triaxial compression tests are plotted in Figures 3-1 thru 3-3.

SUMMARY OF SUBSURFACE CONDITIONS ENCOUNTERED

Boring B-1 was located near the southwest corner of W Church Street and N 1st Street. The boring initially encountered 18.5 feet of firm to stiff silty clay. The N-values of the silty clay ranged from 7 to 9 blows per foot (bpf). An unconsolidated-undrained (UU) triaxial test performed on a specimen from 13.5 to 15.5 feet measured an undrained shear strength (s_u) of about 1000 pounds per square foot (psf).

Underlying the silty clay is sandy and clayey silt to the termination depth of 20 feet. The sandy and clayey silt is loose with an N-value of 5 bpf.

Boring B-2 was drilled near the northwest corner of N 1st Street and W Main Street and encountered silty clay fill from the ground surface to about 2 feet deep. Stiff to firm silty clay was encountered beneath the silty clay fill to a depth of 18.5 feet. The N-values of the silty clay ranged from 6 to 9 bpf. A UU test performed on a specimen from 13 to 15 feet measured an s_u of about 1000 psf. Underlying the silty clay is sandy and clayey silt to the termination depth of 20 feet. The sandy and clayey silt is loose with an N-value of 6 bpf.

Boring B-3 was drilled near the southwest corner of N 1st Street and W Main Street and encountered stiff, high plastic clay from the ground surface to about 8.5 feet deep. The high plastic clay has an N-value of 11 bpf. This is underlain by clayey silt to 11 feet deep, which has an N-value of 8 bpf. Firm to stiff silty clay was then encountered from 11 to 18.5 feet deep. The silty clay has an N-value of 6 bpf and a UU test on a specimen obtained from 13 to 15 feet measured an s_u of about 1200 psf. Underlying the silty clay is sandy and clayey silt to the termination depth of 20 feet. The sandy and clayey silt is loose with an N-value of 5 bpf.

Groundwater was not encountered during drilling, and was not present before the termination of the borings at 20 feet deep. Delayed groundwater measurements were not performed.

EVALUATION AND RECOMMENDATIONS

Design of Manholes

Generally, the soil bearing pressure is not a concern because the overburden soil pressure at the invert of the manhole is reduced. We recommend using an allowable net bearing pressure of 3000 psf. The maximum net bearing pressure is limited by the acceptable settlement. The estimated settlement for a 4-foot square footing with these net bearing pressures is about 1 inch. The “net” bearing pressure is the vertical pressure at the base of the footing that is in excess of the existing vertical earth pressure at that depth. We recommend using a total unit weight of 127 pcf to calculate the gross pressure. The footing bearing surface for new manholes will be in stiff to firm silty clay. The design factor of safety is 3.0.

Open Excavations & Shoring

The preliminary plans for the new sewer indicate that open excavation will be used from W Church Street to W Main Street and that trenchless methods will be used beneath W Main Street. We assume that bore pits will be required for tunneling. The excavations will require shoring, probably using internal bracing, or sloping where possible. If sloped, OSHA Type B excavation is applicable to 15 feet due to the firm to stiff silty clay, which is a maximum slope of 1 horizontal to 1 vertical. If seepage occurs from the face of the cut, or vibrations from traffic are present, then OSHA Type C is applicable. If weak layers are encountered or the excavation is left exposed to become saturated or degrade, then the excavation must be re-evaluated according to OSHA regulations.

The OSHA soil classifications in excavations not at the boring location will not be revealed until they are excavated. Therefore, the contractor shall be responsible for determining the soil types and the

appropriate side slopes or shoring and shall be solely responsible for compliance with OSHA regulations for excavations and job site safety.

While sloping is an option, adjacent buildings, utilities and roadways will likely prevent adequate clearance for sloping excavations and a shoring system may be required. Shoring systems must be designed by an experienced registered Professional Engineer. Recommended minimum lateral earth pressures depend on the soil type. A trapezoidal lateral earth pressure diagram should be used for the design of braced shoring. This is illustrated in Figure 4.

If the excavation subgrade (including over-excavation) is below a 45° line extending downward from the toe of the footing then shoring is required. The shoring must be designed for an additional uniform surcharge pressure due to the footing. An additional surcharge pressure of 500 psf may be used unless data on the footing and structure are available. A trench box does NOT constitute temporary shoring for structures; a trench box is only for the protection of personnel in the excavation.

An additional uniform surcharge pressure of 80 psf should be added where there is traffic. Also, an additional uniform surcharge pressure should be added where there is a surface load due to equipment or materials; The surcharge pressure should be 40% of the vertical surface load.

The illustration shown in Figure 4 is only to represent the recommended lateral earth pressures. It does not represent a valid shoring scheme. A pre-engineering shoring system may be used.

Subgrade and Bedding

The subgrade of the sewer will be in stiff silty clay. The subgrade is suitable to support the new sewer. However, the silty clay may lose strength if disturbed or water is allowed to collect in the excavation. Pipe bedding requirements will vary based on the loading, size, type and class of the new pipe. Assuming the new pipe will be flexible and have a diameter less than 18 inches, we recommend the bedding have a minimum thickness of 4 inches and consist of a well-graded crushed limestone, such as MSD 3 (3/4"-minus with sufficient fines).

Control of Ground Water

Groundwater was not encountered in the borings during drilling. The groundwater level experienced during drilling is only representative of the time during sampling. Groundwater levels vary with season and precipitation. The soils encountered above the flowline of the proposed sewer are relatively impervious. If groundwater is encountered, extraordinary dewatering should not be required.

Tunneling

The plans for the new sewer indicate that tunneling will be used for the crossing under W Main Street/ IL-177. We expect that the contractor will have a small bore pit on either side of W. Main Street. Based on the borings, the soils at the sewer depth have relatively consistent strengths and consistencies; we do not expect mixed faces drilling.

Backfilling

The low plastic clay material on-site could be used as backfill if properly compacted, but the high plastic clay should not be used as backfill unless properly conditioned and compacted.

Areas to be filled shall be cleared of trees, stumps, brush, trash, sod, topsoil, and loose soil. Low plastic on-site material should be compacted in uniform, horizontal lifts. Imported fill should consist of uncontaminated, inert, non-expansive soils classified as silty clay (CL), clayey silt (ML), sandy clay or clayey sand (SC). High plastic clay should not be used for structural fill unless the clays are treated to reduce the plasticity. The liquid limit of clayey soils should be less than 45%, and the plasticity index should be at least 10%. Imported fill should not contain roots or other similar organic matter, trash, frozen material, chemical contamination, or rock or concrete fragments larger than 6 inches in the maximum dimension.

Fill should be placed in uniform, horizontal lifts and compacted with systematic coverages of the entire lift. The thickness of the loose lift (prior to compaction) should not exceed 12 inches where large, self-propelled compaction equipment can be used. In confined areas or immediately adjacent to retaining walls, where manual compactors are required, the lift thickness should not exceed 6 inches prior to compaction.

The compaction characteristics of fine-grain soils, such as clays or clayey silts, are dependent upon water content. For these materials, the water content should be adjusted prior to compaction, either by sprinkling additional water, or by scarifying, discing and drying to lower the water content. The existing near-surface soils will probably require drying prior to compaction, depending upon the season of construction.

We recommend that fine-grain soils or granular fill with fines (non-free draining) have a minimum compacted dry unit weight equal to 95% of the maximum dry unit weight ($\gamma_{d,max}$) determined by the Standard Proctor method (ASTM D698). For fills placed below pavement, we recommend that the top 2 feet of fill immediately under the pavement be compacted to a dry unit weight equal to at least 98% of the same $\gamma_{d,max}$. The moisture content of the fill at the time of compaction should be greater than the optimum moisture content determined from the same Proctor test. The maximum moisture content will be governed by the required minimum dry unit weight.

Granular fill materials should be well-graded, crushed limestone. The compaction of granular fill with sufficient fines that is non-free draining should be in accordance with recommendations for general fill. The compaction of free-draining granular materials with little fines is based on the minimum and maximum densities determined by laboratory tests (ASTM D4253 and D4254). Free-draining granular fill should be compacted to a minimum relative density of 75%.

Summary of Recommendations

The following is a summary of our recommendations as explained in this report:

1. We recommend using an allowable net bearing pressure of 3000 psf. The maximum net bearing pressure is limited by the acceptable settlement. The estimated settlement for a 4-foot square footing with these net bearing pressures is about 1 inch.

2. All excavations will require sloping or shoring in accordance with OSHA requirements. The general OSHA Classification is B.
3. Groundwater was not encountered in the borings during drilling. The soils encountered above the flowline of the proposed sewer are relatively impervious. If groundwater is encountered, extraordinary dewatering should not be required.
4. The subgrade of the sewer will be in stiff silty clay and appears suitable to support the new sewer. We recommend the pipe bedding have a minimum thickness of 4 inches and consist of a well-graded crushed limestone.
5. The soils at the sewer depth have relatively consistent strengths and consistencies; we do not expect mixed faces drilling.

LIMITATIONS

The boring logs depict subsurface conditions for specific locations and dates. The recommendations and observations presented in the report assume that significant variations do not occur. Non-uniform conditions, however, often cannot be determined by the procedures described. Where present, such conditions may necessitate additional expenditures to obtain a properly constructed project. We recommend that a contingency fund be budgeted to accommodate such possible variations.

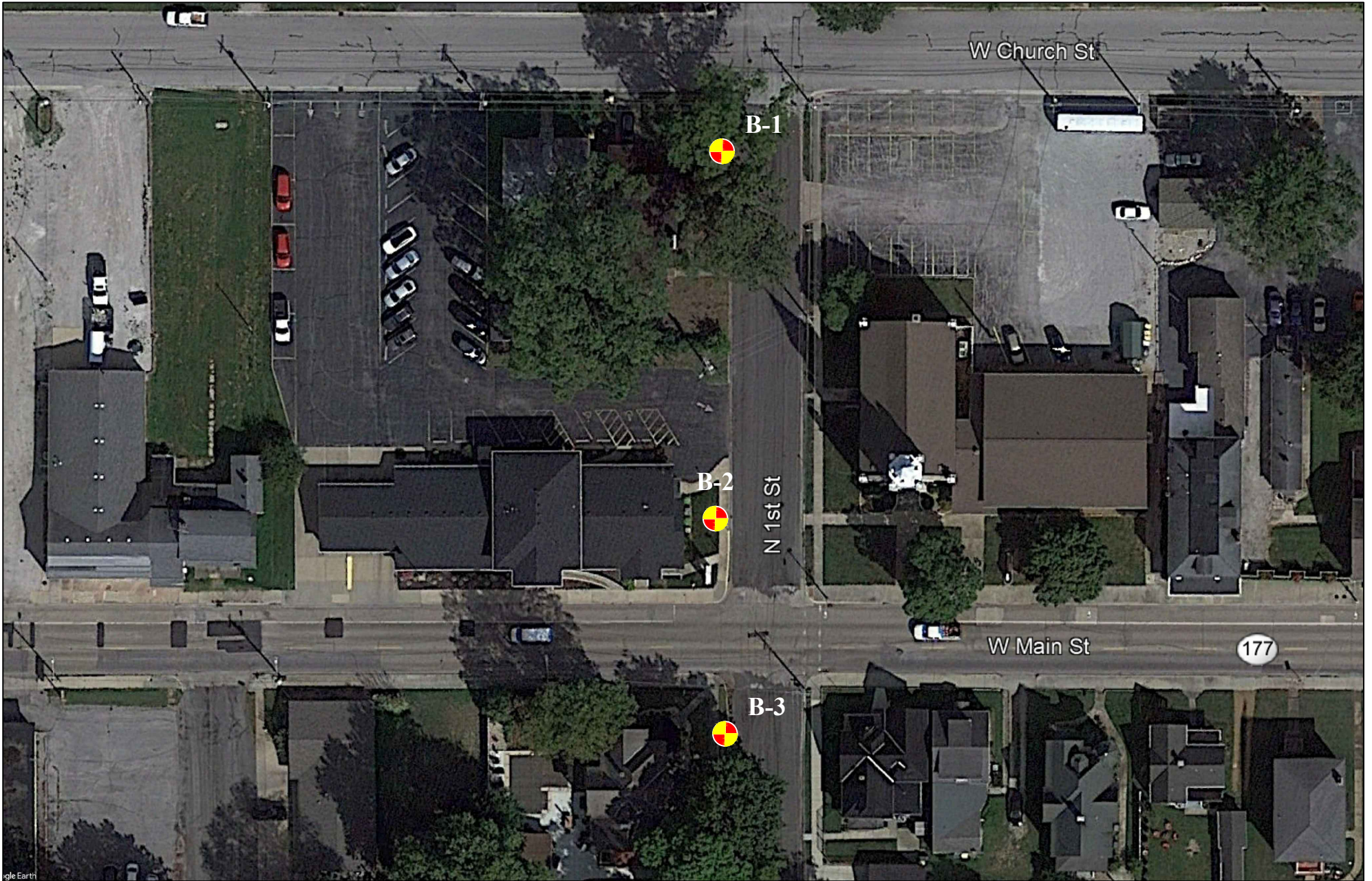

Boring # 



RJN Group: Sanitary Sewer Line Replacement
in Mascoutah, Illinois
Boring Location Sketch

Figure 1

KEY TO BORING LOGS

Symbol Description

KEY TO SOIL SYMBOLS



Low plastic Silty CLAY (CL)



Clayey Sandy SILT (ML)



Miscellaneous FILL



High plastic CLAY (CH)



Low plastic Clayey SILT (ML)

MISCELLANEOUS SYMBOLS



Sewer Invert



Moisture content (%)



N-value from Standard Penetration Test, ASTM D-1586 (blows/ft)

SOIL SAMPLERS



2-in. O.D. Split-Spoon



3-in. O.D. Shelby Tube

Notes:

1. Midwest Drilling of Florissant, Missouri was subcontracted by Reitz & Jens to perform the geotechnical borings. The borings were advanced using 4.25" O.D. solid stem augers. Once complete the borings were backfilled with gravel and topped with topsoil. 2. The borings were made with CME-750 ATV-mounted drill rigs equipped with an automatic Standard Penetration Test (SPT) hammer. The energy efficiency of the drilling rig's automatic SPT hammer has historically been measured to be about 60%.
3. The borings were located in the field using measured distances from existing site features. The borings were moved, to maintain safe clearance from overhead and buried utilities.
4. The borings were logged in the field by a Reitz & Jens' geotechnical engineer, based upon the recovered samples, cuttings and drilling characteristics. Samples were transported to Reitz & Jens' lab for testing. Field logs were revised, if needed, based upon laboratory classification and testing.
5. Stratification lines shown on the logs represent approximate soil boundaries; actual changes in strata may be gradual or occur between samples.

Figure 2-0



Mascoutah 20202021 Sanitary Sewer Rehabilitation
CLIENT: **RJN**

LOCATION: See Figure 1
ELEVATION: _____ DATUM: _____
DATE DRILLED: 04-16-2020

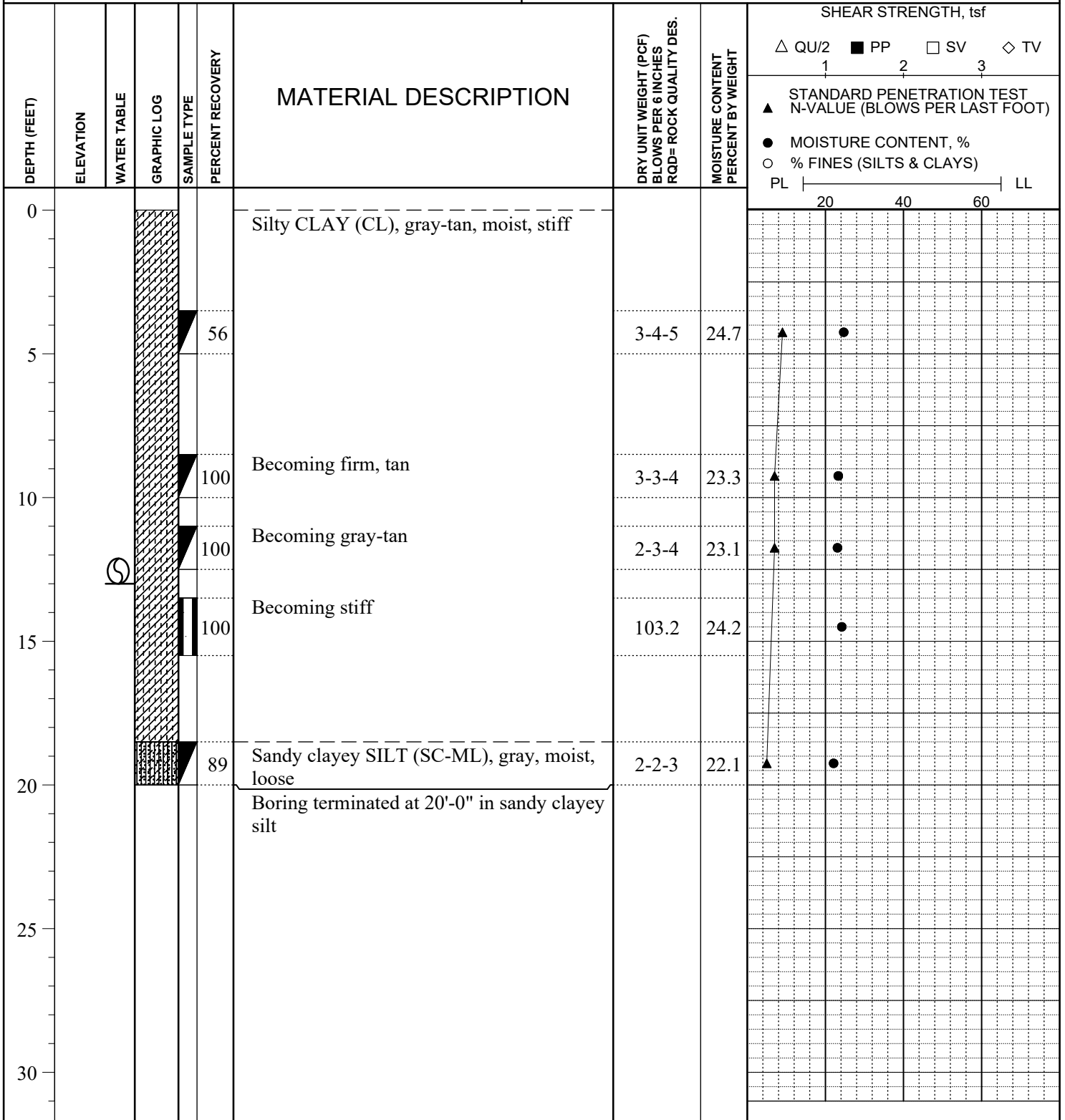

DRILLER: Midwest Drilling
METHOD: 4.25" CFA
TYPE OF SPT HAMMER: Automatic
HAMMER EFFICIENCY (%): 63.9
LOGGED BY: C. Cook

STRATIFICATION LINES ARE APPROXIMATE SOIL BOUNDARIES ONLY; ACTUAL CHANGES MAY BE GRADUAL OR MAY OCCUR BETWEEN SAMPLES.

WATER LEVELS: DURING DRILLING Dry FEET
BORING DRY AT COMPLETION OF DRILLING
AT _____ FEET AFTER _____ HOURS
AT _____ FEET AFTER _____ HOURS
PIEZOMETER: INSTALLED AT _____ FEET



Mascoutah 20202021 Sanitary Sewer Rehabilitation
CLIENT: **RJN**

LOCATION: See Figure 1
ELEVATION: _____ DATUM: _____
DATE DRILLED: 04-16-2020

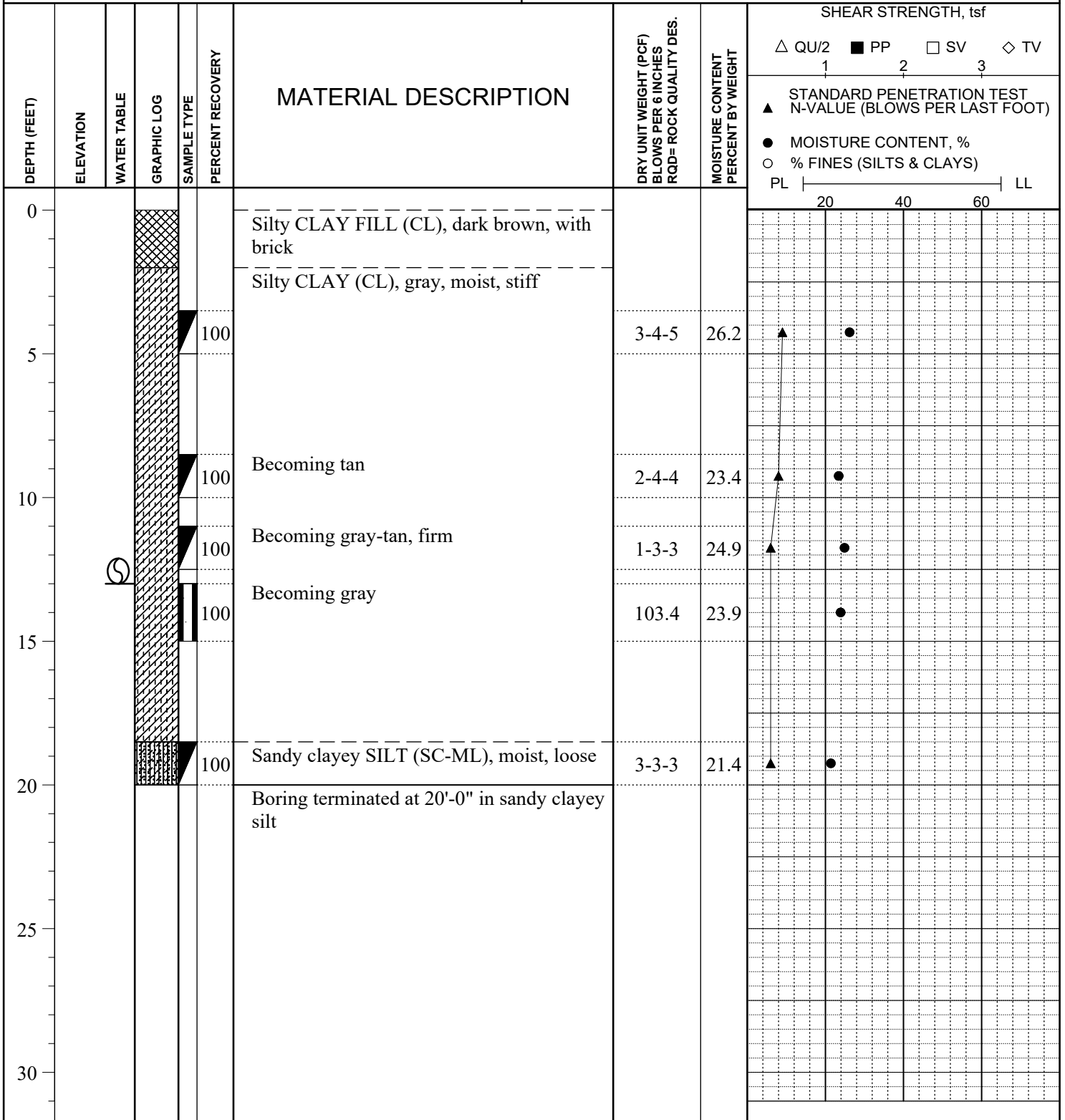

DRILLER: Midwest Drilling
METHOD: 4.25" CFA
TYPE OF SPT HAMMER: Automatic
HAMMER EFFICIENCY (%): 63.9
LOGGED BY: C. Cook

STRATIFICATION LINES ARE APPROXIMATE SOIL BOUNDARIES ONLY; ACTUAL CHANGES MAY BE GRADUAL OR MAY OCCUR BETWEEN SAMPLES.

WATER LEVELS: DURING DRILLING Dry FEET
_____ Y BORING DRY AT COMPLETION OF DRILLING
AT _____ FEET AFTER _____ HOURS
AT _____ FEET AFTER _____ HOURS
PIEZOMETER: INSTALLED AT _____ FEET



Mascoutah 20202021 Sanitary Sewer Rehabilitation
CLIENT: **RJN**

LOCATION: See Figure 1
ELEVATION: _____ DATUM: _____
DATE DRILLED: 04-16-2020

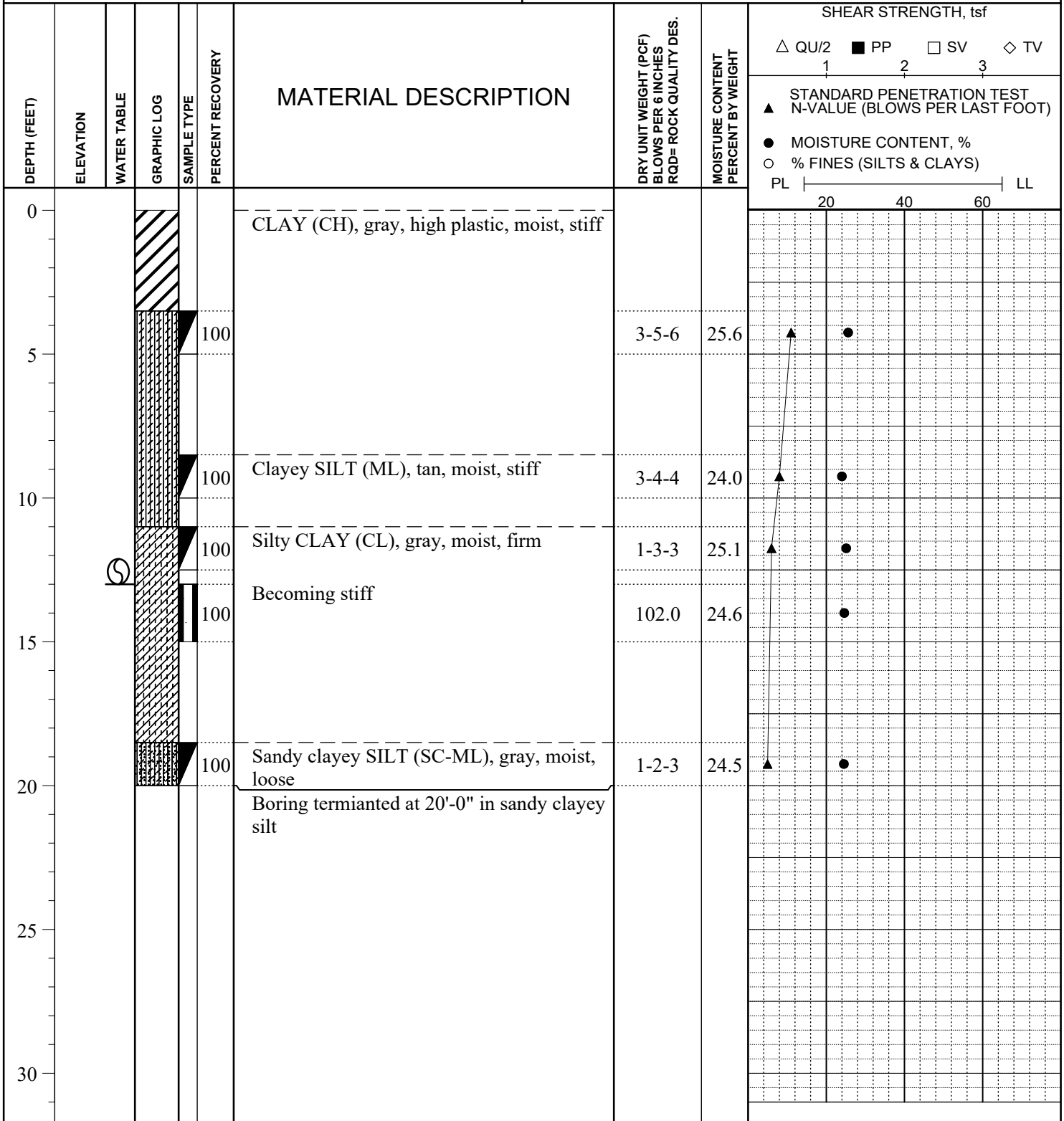

DRILLER: Midwest Drilling
METHOD: 4.25" CFA
TYPE OF SPT HAMMER: Automatic
HAMMER EFFICIENCY (%): 63.9
LOGGED BY: C. Cook

STRATIFICATION LINES ARE APPROXIMATE SOIL BOUNDARIES ONLY; ACTUAL CHANGES MAY BE GRADUAL OR MAY OCCUR BETWEEN SAMPLES.

WATER LEVELS: DURING DRILLING Dry FEET
BORING DRY AT COMPLETION OF DRILLING
AT _____ FEET AFTER _____ HOURS
AT _____ FEET AFTER _____ HOURS
PIEZOMETER: INSTALLED AT _____ FEET

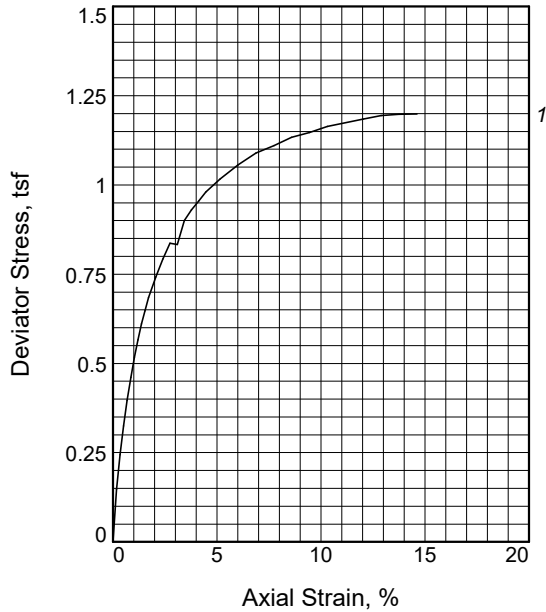
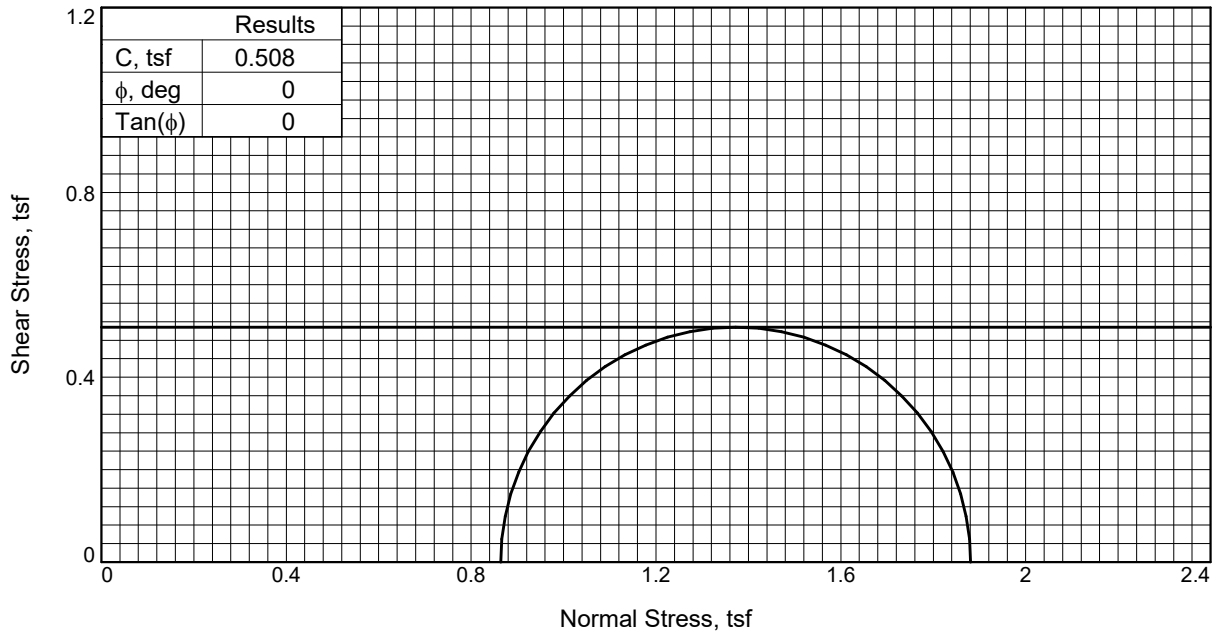

Sample No.	1	
Initial	Water Content, %	24.2
	Dry Density, pcf	103.2
	Saturation, %	104.4
	Void Ratio	0.6214
	Diameter, in.	2.85
At Test	Height, in.	5.82
	Water Content, %	24.2
	Dry Density, pcf	103.2
	Saturation, %	104.4
	Void Ratio	0.6214
Strain rate, %/min.	Diameter, in.	2.85
	Height, in.	5.82
	Back Pressure, tsf	0.00
	Cell Pressure, tsf	0.86
	Fail. Stress, tsf	1.02
	Strain, %	5.2
	Ult. Stress, tsf	1.20
	Strain, %	14.6
	σ_1 Failure, tsf	1.88
	σ_3 Failure, tsf	0.86

Type of Test:

Unconsolidated Undrained

Sample Type: Shelby Tube

Description: Silty CLAY (CL), gray, moist, stiff

Assumed Specific Gravity= 2.68

Remarks:

Client: RJN

Project: Mascoutah 20202021 Sanitary Sewer Rehabilitation

Source of Sample: B-1

Depth: 13.5

Sample Number: ST-4

Proj. No.: 202008307

Date Sampled: 04-17-2020



Figure 3-1

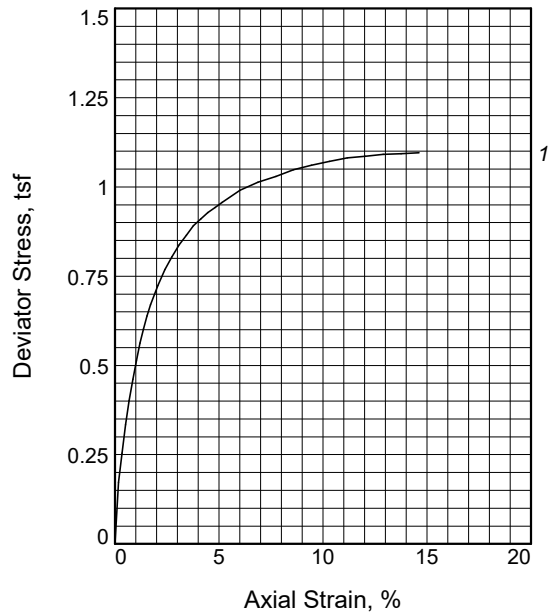
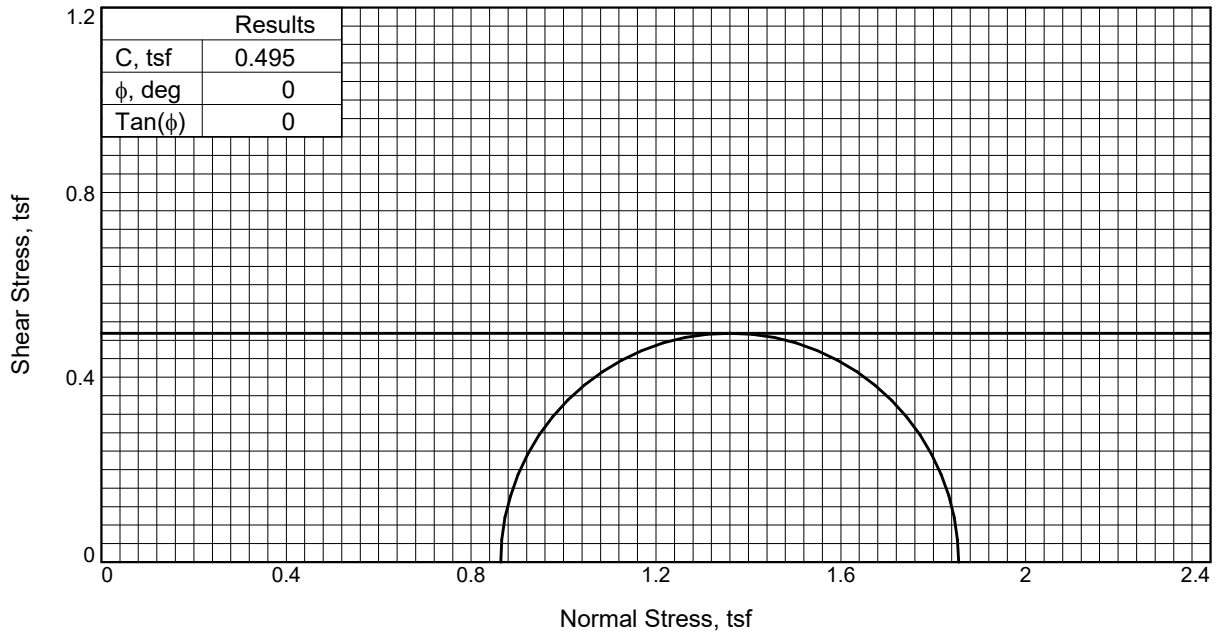

Sample No.	1	
Initial	Water Content, %	23.9
	Dry Density, pcf	103.4
	Saturation, %	103.3
	Void Ratio	0.6188
	Diameter, in.	2.85
At Test	Height, in.	5.82
	Water Content, %	23.9
	Dry Density, pcf	103.4
	Saturation, %	103.3
	Void Ratio	0.6188
Strain rate, %/min.	Diameter, in.	2.85
	Height, in.	5.82
	Back Pressure, tsf	0.00
	Cell Pressure, tsf	0.86
	Fail. Stress, tsf	0.99
	Strain, %	6.0
	Ult. Stress, tsf	1.10
	Strain, %	14.6
	σ_1 Failure, tsf	1.85
	σ_3 Failure, tsf	0.86

Type of Test:
Unconsolidated Undrained

Sample Type: Shelby Tube

Description: Silty CLAY (CL), gray, moist,

Assumed Specific Gravity= 2.68

Remarks:

Client: RJN

Project: Mascoutah 20202021 Sanitary Sewer Rehabilitation

Source of Sample: B-2 **Depth:** 13

Sample Number: ST-4

Proj. No.: 202008307 **Date Sampled:** 04-17-2020



Figure 3-2

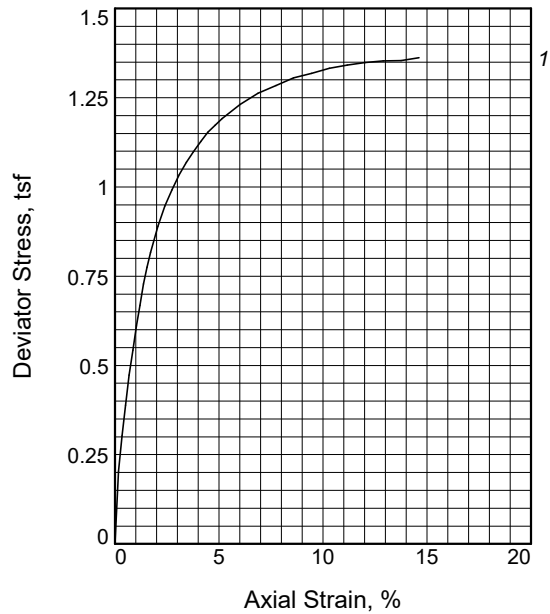
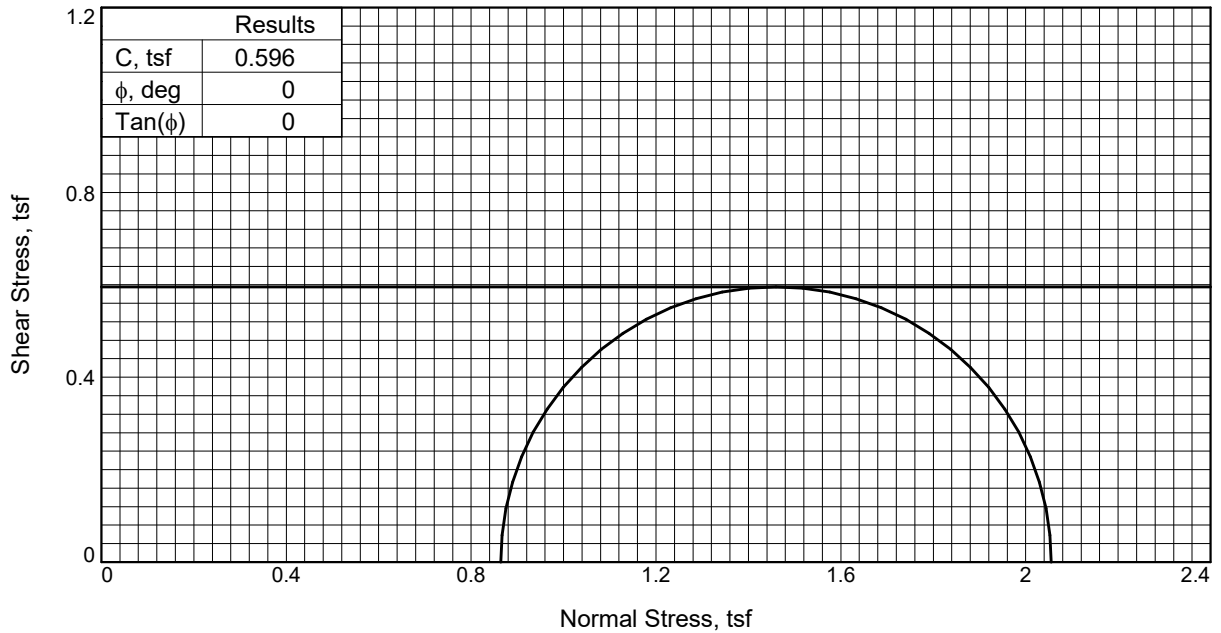

Sample No.	1	
Initial	Water Content, %	24.6
	Dry Density, pcf	102.0
	Saturation, %	102.9
	Void Ratio	0.6399
	Diameter, in.	2.85
At Test	Height, in.	5.82
	Water Content, %	24.6
	Dry Density, pcf	102.0
	Saturation, %	103.0
	Void Ratio	0.6399
Strain rate, %/min.	Diameter, in.	2.85
	Height, in.	5.82
	Back Pressure, tsf	0.00
	Cell Pressure, tsf	0.86
	Fail. Stress, tsf	1.19
	Strain, %	5.2
	Ult. Stress, tsf	1.36
	Strain, %	14.6
	σ_1 Failure, tsf	2.06
	σ_3 Failure, tsf	0.86

Type of Test:
Unconsolidated Undrained

Sample Type: Shelby Tube

Description: Silty CLAY (CL), gray-tan, moist, stiff

Assumed Specific Gravity= 2.68

Remarks:

Client: RJN

Project: Mascoutah 20202021 Sanitary Sewer Rehabilitation

Source of Sample: B-3 **Depth:** 13

Sample Number: ST-4

Proj. No.: 202008307 **Date Sampled:** 04-17-2020



Figure 3-3

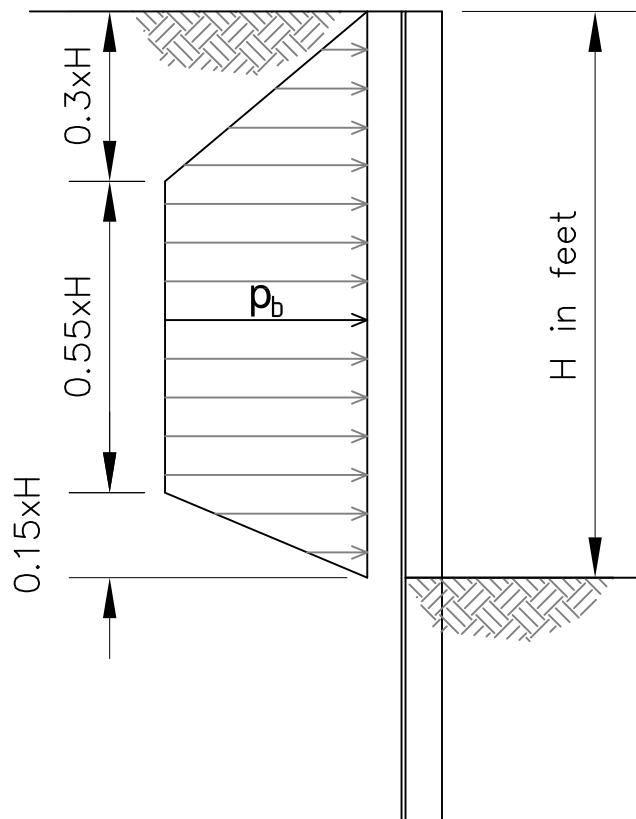

$$p_b = 0.67xH^2 + 8xH, \text{ in psf}$$

LATERAL EARTH PRESSURE DIAGRAM FOR DESIGN
OF BRACED EXCAVATION FOR CLAY WITH SHEAR
STRENGTH OF 1000 PSF