

# PROPOSAL PACKET

CITY OF MASCOUTAH

SCHEVE PARK EXPANSION

BID DATE: 10:00 a.m., May 27, 2021

## **Invitation for Bids – Scheve Park Expansion**

The City of Mascoutah is seeking bids for grading and seeding approximately 13 acres of unimproved land for the expansion of Scheve Park. Sealed bids will be accepted at the office of the City Clerk, City of Mascoutah, 3 West Main Street, Mascoutah, IL 62258 until 10:00am (local time), May 27, 2021 at which time bids will be opened. Bid Proposal Packets will be available at no cost at the office of the City Clerk and at [www.mascoutah.org](http://www.mascoutah.org). All bidders must register as a plan holder by contacting the City Clerk at 618-566-2964 Ext. 106. Bid proposals submitted from bidders not registered with the City will be considered invalid and will not be opened.

## **Bidders Instructions**

1. Proposal Packets and Specifications will be available in the office of the City Clerk, 3 West Main Street, Mascoutah, IL 62258 and at [www.mascoutah.org](http://www.mascoutah.org). There will be no pre-bid meeting.
2. All proposals must be accompanied by a Proposal Guaranty in the amount of 5% of the bid amount in the form of a Cashier's Check made payable to the Treasurer of the City of Mascoutah or a Bid Bond payable to the City of Mascoutah.
3. Bidders are required to provide lump sum prices for all items listed on the specifications and perform or subcontract all work items on this project. The City will award all work specified to a single General Contractor.
4. The City reserves the right to waive technicalities and to reject any or all proposals and to select the lowest or best BID.
5. Bidders are required to complete this project by October 15, 2021. Notice of Award by the City is anticipated to be issued on June 8, 2021 contingent upon bid award at the June 7, 2021 City Council Meeting.
6. Bidders are required to be licensed and insured to perform this type of work in the State of Illinois. Copy of said business license must be included with proposal.
7. This project is subject to the State of Illinois Prevailing Wage Act. Information regarding prevailing wage, benefit and working condition requirements may be obtained from the Illinois Department of Labor (IDOL) at 217-782-6206 and information may be viewed at their website <http://www.state.il.us/agency/idol/>.
8. Weekly certified payrolls shall be submitted to the City and invoice for work will be due upon completion of the project and payable within thirty days. Certified payrolls must be submitted prior to pay requests.
9. All bid proposals shall be marked to clearly indicate its contents and when sent by mail, sealed proposals shall be addressed to the City Clerk as noted herein.
10. All proposals shall be filed prior to the time and at the place specified herein and all proposals received after the time specified will be returned to the bidder unopened.
11. Permission will be given to a Bidder to withdraw a proposal if the Bidder makes a request in writing or in person before the time for opening proposals.
12. Awarded contractor will be required to submit: performance bond (100% of bid amount) and liability insurance certificate (naming project and listing City of Mascoutah as additional insured).

By Order of

The City of Mascoutah

Melissa Schanz, City Clerk

**SCHEDULE OF PRICES**  
CITY OF MASCOUTAH  
SCHEVE PARK EXPANSION

BID DATE: 10:00 AM, May 27, 2021

BIDDERS NAME: \_\_\_\_\_

ADDRESS: \_\_\_\_\_

CITY, STATE: \_\_\_\_\_

<b>Item</b>	<b>Quantity</b>	<b>Unit</b>	<b>Unit Price</b>	<b>Amount</b>
Mobilization	1	L Sum		
Erosion Control	1	L Sum		
Earthwork	1	L Sum		
Grading and Shaping Ditches	1	L Sum		
Seeding	1	L Sum		
Mulch	1	L Sum		

**TOTAL LUMP SUM PROJECT BID: \$** \_\_\_\_\_

**Bidders Signature**

By: \_\_\_\_\_

Title: \_\_\_\_\_

**CONTRACT**  
**Scheve Park Expansion**  
**City of Mascoutah**

1. THIS AGREEMENT, made and concluded the \_\_\_\_ day of \_\_\_\_\_, 2021, between the City of Mascoutah, Illinois acting by and through its Mayor and City Council known as the party of the first part, and \_\_\_\_\_ his/their executors, administrators, successors or assigns, known as the party of the second part.
2. Project Description:
  - A. Project Name: SCHEVE PARK EXPANSION
  - B. Location: Scheve Park, Mascoutah, IL 62258
  - C. This project consists of grading and seeding approximately 13 acres of unimproved land for the expansion of Scheve Park in the City of Mascoutah. The work will include earth excavation, grading and seeding as specified in the attached Proposal Packet. All construction debris shall be removed from the site by the contractor and properly disposed.
3. Witnesseth: That for and in consideration of the payments and agreements stated in the Proposal Packet hereto attached, to be made and performed by the party of the first part, the party of the second part agrees with said party of the first part at his/their own proper cost and expense to do all work, furnish all material, labor and equipment necessary to complete the work in accordance with the specifications herein described and attached, and in full compliance with all of the terms of this agreement and state statutes, and furnish the party of the first part documentation indemnifying the said party of the first part against future liability claims.
4. This project is subject to the State of Illinois Prevailing Wage Act. Information regarding prevailing wage, benefit and working condition requirements may be obtained from the Illinois Department of Labor (IDOL) at 217-782-6206 and information may be viewed at their website <http://www.state.il.us/agency/idol/>. Weekly certified payrolls shall be submitted to the City and invoice for work will be due upon completion of the project and payable within thirty days. Certified payrolls must be submitted prior to pay requests.
5. And it is also understood and required as a condition to this CONTRACT that the party of the second part is licensed and insured to perform this type of work and shall furnish the party of the first part a copy of said business license and insurance prior to start of work.
6. And it is also understood and required as a condition to this CONTRACT that the party of the second part shall furnish the party of the first part lien waivers on all material suppliers (and equipment rental if applicable) used for said project prior to final payment of said contract being paid upon completion of project.
7. Completion Date: The party of the second part shall complete all work on or before October 15, 2021.

8. Indemnification: To the fullest extent permitted by law, the Contractor shall be responsible for any and all injuries to persons or damages to property due to the activities of the Contractor, subcontractors, suppliers, agents, or employees arising out of or resulting from performance of the contract, or any activity in connection therewith. The Contractor shall indemnify and hold harmless the City of Mascoutah, its officers, employees, and agents from any and all claims, lawsuits, actions, costs, and fees (including reasonable attorney fees and expenses) of every nature or description, arising from, growing out of, or connected with the work, or on account of or in consequence of any neglect in safeguarding the work or on account of or in consequence of using unacceptable materials in constructing the work or because of any act or omission, neglect, or misconduct of the Contractor, its officers, employees, agents, its subcontractor, or subcontractors, anyone directly or indirectly employed by them, and/or anyone for whose acts they may be liable or because of any claims or amount recovered by reason of any infringement of any patent, trademark, or copyright or by reason of the violation of any law, ordinance, order or decree. This obligation is binding on the Contractor without regard to whether or not such claim, damage, loss, or expense is caused in part by the act, omission, or negligence of the City of Mascoutah or its officers, employees, or agents.
9. Insurance: The Contractor shall obtain and thereafter keep in force the following insurance coverages provided by insurance companies acceptable to the City of Mascoutah and authorized to transact business under the laws of the State of Illinois. The insurance companies providing coverage shall be rated in the Best's Key Rating Guide. The City of Mascoutah will accept companies with a rating not lower than B+ provided the financial size category is VII or larger. Companies rated A- or better shall have a financial size category of not less than VI. Coverage limits shall be written at not less than the minimum specified below. Higher minimum limits and additional coverage may be specified by a special provision elsewhere in the contract. Whether stated herewith or elsewhere, the City of Mascoutah does not warrant the adequacy of the types of insurance coverage or the limits of liability specified.
- A. Workers Compensation and Employers Liability.
- (1) Workers compensation shall be provided according to the provisions of the Illinois Worker's Compensation Act, as amended. Notwithstanding the rating and financial size categories stated below, coverage may be provided by a group self-insurer authorized in Section 4(a) of the Act and approved pursuant to the rules of the Illinois Department of Insurance.
- (2) Employers Liability.
- |                          |             |
|--------------------------|-------------|
| a. Each Accident         | \$1,000,000 |
| b. Disease-policy limit  | \$1,000,000 |
| c. Disease-each employee | \$1,000,000 |
- B. Commercial General Liability. Required liability insurance coverage shall be written in the occurrence form and shall provide coverage for operations of the Contractor; operations of subcontractors (contingent or protective liability); completed operations; broad form property damage and hazards of explosion, collapse and

underground; and contractual liability. The general aggregate limit shall be endorsed on a per project basis.

- |     |  |             |
|-----|--|-------------|
| (1) | General Aggregate Limit                          | \$1,000,000 |
| (2) | Products-Completed Operations<br>Aggregate Limit | \$1,000,000 |
| (3) | Each Occurrence Limit                            | \$1,000,000 |

The coverage shall provide by an endorsement in the appropriate manner and form, the City of Mascoutah, its officers, and employees shall be named as additional insureds with respect to the policies and any umbrella excess liability coverage for occurrences arising in whole or in part out of the work and operations performed. The City of Mascoutah may accept a separate owner's protective liability policy in lieu of the City of Mascoutah, its officers, and employees being insureds on the Contractor's policies.

C. Commercial Automobile Liability. The policy shall cover owned, non-owned, and hired vehicles.

- |     |  |             |
|-----|--|-------------|
| (1) | Bodily Injury & Property Damage<br>Liability Limit Each Occurrence | \$1,000,000 |
|-----|--|-------------|

D. Umbrella Liability. Any policy shall provide excess limits over and above the other insurance limits stated herewith. The Contractor may purchase insurance for the full limits required or by a combination of primary policies for lesser limits and remaining limits provided by the umbrella policy.

All insurance shall remain in force during the period covering occurrences happening on or after the effective date and remain in effect during performance of the work and at all times thereafter when the Contractor may be correcting, removing, or replacing defective work until notification of the date of final inspection. Termination or refusal to renew shall not be made without 30 days prior written notice to the City of Mascoutah by the insurer and the policies shall be endorsed so as to remove any language restricting or limiting liability concerning this obligation.

Certified copies of the original policies or certificate(s) of insurance by the insurer(s) issuing the policies and endorsements setting forth the coverage, limits, and endorsements shall be filed with the City of Mascoutah before the City of Mascoutah will execute the contract. A certificate of insurance shall name the city as an additional insured under its policy. Any exception or deviation shall be brought to the attention of the City of Mascoutah for a ruling of acceptability. In no event shall any failure of the City of Mascoutah to receive policies or certificates or to demand receipt be construed as a waiver of the Contractor's obligation to obtain and keep in force the required insurance.

All costs for insurance as specified herein will be considered as included in the cost of the contract. The Contractor shall, at his/her expense and risk of delay, cease operations if the insurance required is terminated or reduced below the required amounts of coverage. Coverage in the minimum amounts set forth herein shall not be construed to relieve the

Contractor from his/her obligation to indemnify in excess of the coverage according to the contract.

10. IN WITNESS WHEREOF, The said parties have executed these presents on the date above mentioned.

Attest:

The City of Mascoutah, Illinois

\_\_\_\_\_  
Melissa Schanz  
City Clerk

By \_\_\_\_\_  
Bradley E. Myers  
City Manager

(Seal)

Corporate Name \_\_\_\_\_.

By \_\_\_\_\_

\_\_\_\_\_  
Title



## **SPECIAL PROVISIONS**

The following provisions supplement the “Standard Specifications for Road and Bridge Construction”, Adopted April 1, 2016, and the “Supplemental Specifications and Recurring Special Provisions” thereto adopted and in effect on the date of the invitation for bids, which apply to and govern the construction of SCHEVE PARK EXPANSION, Mascoutah, Illinois and in case of conflict with any part, or parts of said Specifications, the said provisions shall take precedence and shall govern.

### **DESCRIPTION OF WORK**

This project consists of grading and seeding approximately 13 Acres of unimproved land for the expansion of Scheve Park in the City of Mascoutah. The work will include earth excavation, grading and seeding.

### **CONSTRUCTION STAKING**

The City will provide control points and a cad file for the preparation of a GPS surface file for machine control.

### **EARTHWORK**

This item shall consist of all excavation, disposal of unsuitable material, and final grading in accordance with applicable portions of Section 202 of the “Standard Specifications”. An estimated 4,500 cubic yards of earth excavation will be required.

All culverts and storm sewers shown on the project plans have been installed and are not part of this contract. Grading shall be completed to match the flowlines as shown on the plans or the as constructed flowlines, if different from the plans.

This item of work will not be measured separately and shall be paid for at the contract unit price per Lump Sum for EARTHWORK complete, and no additional compensation will be allowed.

### **GRADING AND SHAPING DITCHES**

This item shall consist of grading and shaping the existing ditch along N 10<sup>th</sup> Street on the west side of the park expansion, to reestablish the original flowline. This work shall be completed in accordance with Section 214 of the “Standard Specifications”. The ditch is approximately 585 feet in length.

This item of work will not be measured separately and shall be paid for at the contract unit price per Lump Sum for GRADING AND SHAPING DITCHES and no additional compensation will be allowed.

## **SEEDING**

This item shall consist of preparing the seed bed and furnishing, transporting and placing seed and fertilizer over the entire project area in accordance with applicable portions of Section 250 of the “Standard Specifications”. The seed mixture shall be Sports Turf Blend by Belleville Seed House, or equal Type 1 Lawn Mixture approved by the City. Seed shall be applied at a rate of 350 pounds per acre. Fertilizer consisting of equal parts Nitrogen, Phosphorus, and Potassium shall be applied at a rate of 270 pounds per acre.

In addition to the requirements of Article 250.05 of the Standard Specifications, the seed bed shall be conditioned using a Cultimulcher, Harley Rake, or other soil conditioning equipment approved by the City.

Seed shall be sown with a machine that mechanically places the seed in direct contact with the soil, packs, and covers the seed in one continuous operation.

Seeding shall be completed between September 15<sup>th</sup> and October 15<sup>th</sup>. The contractor shall guarantee a minimum 90 percent uniform growth over the entire seeded area. Areas sustaining less than 90 percent uniform growth shall be interseeded or reseeded, as determined by the City, at no additional cost to the City.

This item of work will not be measured separately and shall be paid for at the contract unit price per Lump Sum for SEEDING complete, and no additional compensation will be allowed.

## **MULCH**

This item shall consist of furnishing, transporting and placing mulch over the entire project area in accordance with applicable portions of Section 251 of the “Standard Specifications”. Mulch shall be applied at a rate of 2 tons per acre using Mulch Method 2.

This item of work will not be measured separately and shall be paid for at the contract unit price per Lump Sum for MULCH and no additional compensation will be allowed.



**LEGEND**

- 500 --- CONTOUR LINE
- SAN --- SANITARY SEWER
- W --- WATER LINE
- UT --- UNDERGROUND TELEPHONE/ COMMUNICATION LINE
- UE --- UNDERGROUND ELECTRIC
- G --- GAS LINE
- X --- FENCE LINE
- P --- PIPE CULVERT
- ☐ TELEPHONE PEDESTAL
- ⊙ MANHOLE
- ⊕ WATER METER
- ⊖ WATER VALVE
- ⊙ GAS VENT
- ⊙ CABLE TV PEDESTAL
- ⊙ UTILITY POLE
- ⊙ UTILITY POLE/ LIGHT
- ⊕ 100.00 PROPOSED SPOT ELEVATION

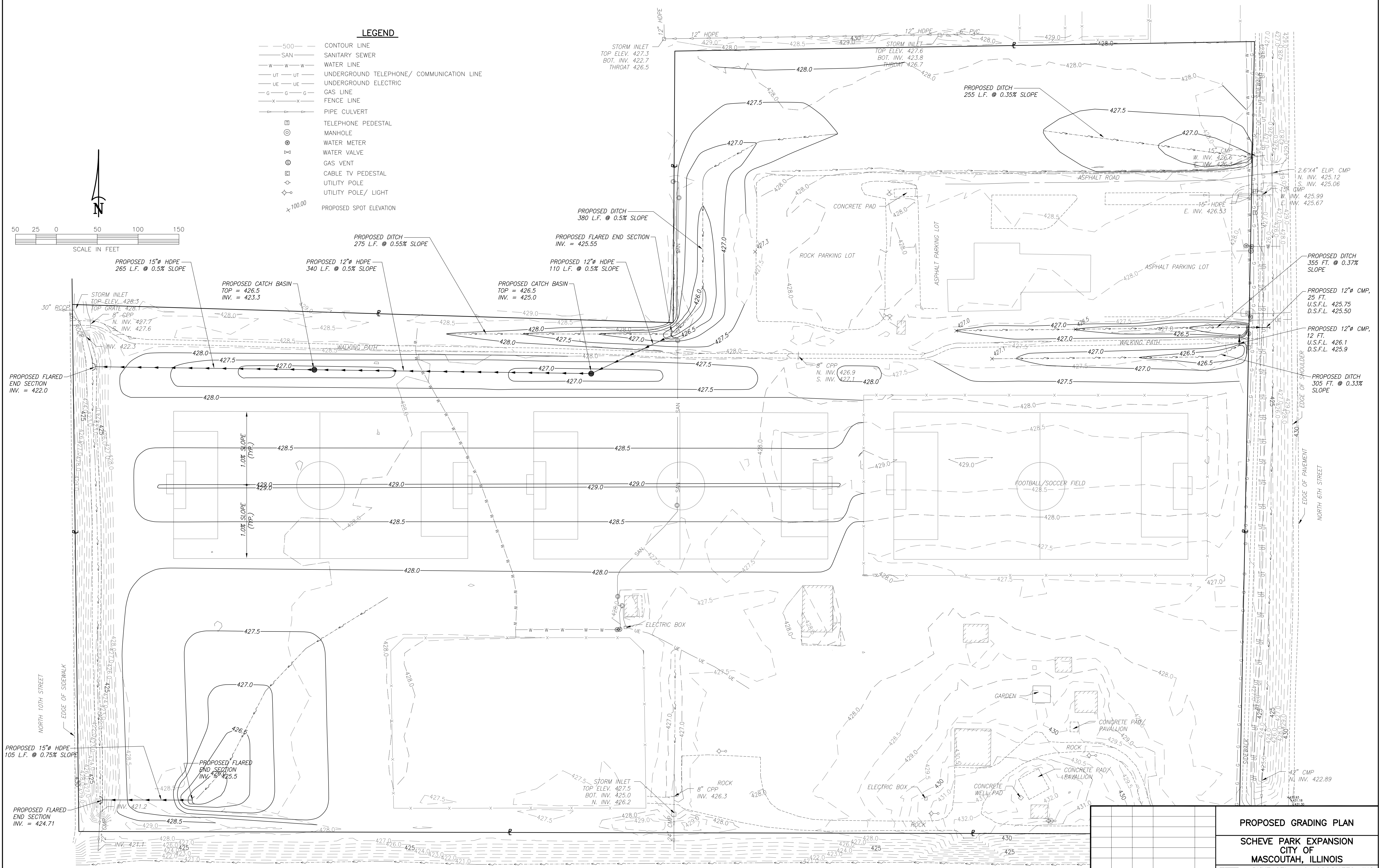
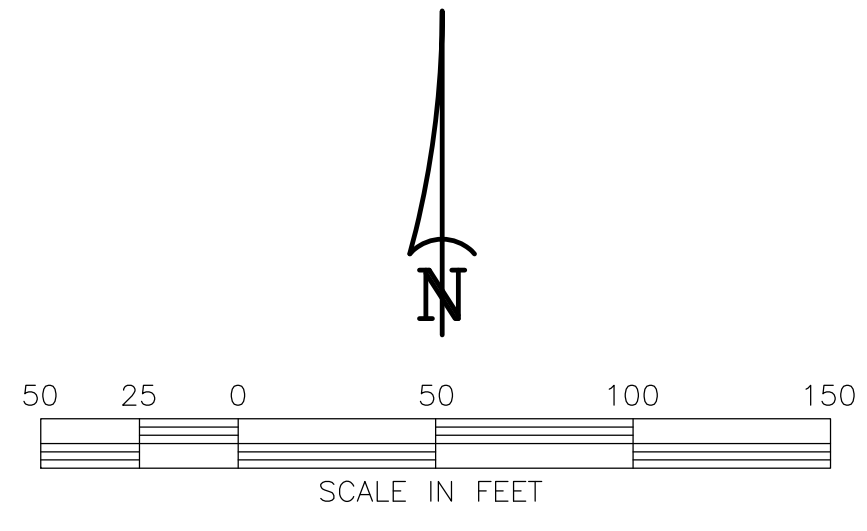

PROPOSED GRADING PLAN			
SCHEVE PARK EXPANSION CITY OF MASCOUTAH, ILLINOIS			
<b>RHUTASEL and ASSOCIATES, INC.</b> CONSULTING ENGINEERS • LAND SURVEYORS P.O. BOX 97 4 INDUSTRIAL DRIVE FREEBURG, IL 62243 TEL: (618) 539-3178 REG. NO. 164-000197			
REVISIONS			
DR. BY:	M.A.L.	APV'D BY:	T.W.P.
CK'D BY:	T.W.P.	RAA#:	52820
SCALE:	AS NOTED	SHEET NO.:	2
DATE:	SEPT. 28, 2020	OF:	3



